



**CATHOLIC UNIVERSITY OF
SANTIAGO DE GUAYAQUIL**
FACULTY OF ARTS AND HUMANITIES
SCHOOL OF ENGLISH LANGUAGE

TITLE OF PAPER

ANNOTATED TRANSLATION OF ETERNA PE1620SA-EXTRA
MANUAL FOR PROCARSA

AUTHOR:

CLARK ARBOLEDA KENNIE GABRIEL

SUBMITTED IN REQUIREMENT FOR OBTAINING THE
BACHELOR OF ARTS DEGREE IN ENGLISH LANGUAGE
WITH A MINOR IN TRANSLATION

PROJECT ADVISOR

ENRÍQUEZ RIVADENEIRA SARA INÉS, MSC.

GUAYAQUIL, ECUADOR

2015



CATHOLIC UNIVERSITY OF SANTIAGO DE GUAYAQUIL

FACULTY OF ARTS AND HUMANITIES

SCHOOL OF ENGLISH LANGUAGE

CERTIFICATION

We certify that this research project was presented by **Kennie Gabriel Clark Arboleda** as a partial fulfillment for the requirements for a **Bachelor of Arts Degree in English Language with a Minor in Translation**.

PROJECT ADVISOR

Sara Rivadeneira Enríquez, MSc.

DIRECTOR OF ACADEMIC PROGRAM

John González Ubilla, MSc.

Guayaquil, in the 20th day of March of 2015



CATHOLIC UNIVERSITY OF SANTIAGO DE GUAYAQUIL

FACULTY OF ARTS AND HUMANITIES

SCHOOL OF ENGLISH LANGUAGE

STATEMENT OF RESPONSIBILITY

I, **Kennie Gabriel Clark Arboleda**,

HEREBY DECLARE THAT:

The Senior Project: **Annotated Translation of ETERNA PE1620SA-Extra manual for PROCARSA** prior to obtaining the **Bachelor of Arts Degree in English Language with a Minor in Translation**, has been developed based on thorough investigation, respecting the intellectual property rights of third parties regarding citations within the corresponding pages whose sources are included in the bibliography. Consequently, this work is of my full responsibility.

Under this statement, I am responsible for the content, truthfulness and scientific scope of the aforementioned paper.

Guayaquil, in the 20th day of March of 2015

AUTHOR

Kennie Gabriel Clark Arboleda



CATHOLIC UNIVERSITY OF SANTIAGO DE GUAYAQUIL

FACULTY OF ARTS AND HUMANITIES

SCHOOL OF ENGLISH LANGUAGE

AUTHORIZATION

I, Kennie Gabriel Clark Arboleda,

Authorize the Catholic University of Santiago de Guayaquil to **publish** this Senior Project: **Annotated Translation of ETERNA PE1620SA-Extra manual for PROCARSA** in the institution's library. The contents, ideas and criteria in this paper are of my full responsibility and authorship.

Guayaquil, in the 20th day of March of 2015

AUTHOR

Kennie Gabriel Clark Arboleda

ACKNOWLEDGEMENTS

As oblivious as it may seem, the random acts of kindness of many people contribute to a great extent to the completion of a task for others. I would like to thank everybody who helped me and guided me through this whole experience that puts an enormous amount of pressure when engaging into the working stream.

I would like to thank God for the opportunity to have gotten this far, for the inspiration and cool headedness granted in order to finish this work.

I would like to thank my parents for guiding me through this journey called life. My brother Jeremy whose support and advice I hold dear. Also to my grandmother Mami Lola whose blessing has stayed with me along my life.

I would like to thank each and every one of the people who tried hard enough to bear my mood during the days and nights of stress. To my girlfriend Edilma Cotapo for being my constant support.

To my teachers at University who could manage to put up with me and take every question at a time. In particular to Miss. Sara Rivadeneira, for urging me to keep on with the hard work for all stages of my life. The same moto that has led me to this day. This other step that needs to be concluded in order to take further greater risks.

Kennie Clark

DEDICATION

To my parents:

Janet del Carmen Arboleda Carrión

Gabriel Clark Fernández

To my family, even the ones who are no longer present.

To my grandmothers, Mami Lola and Mami Rosita. They are that powerful old kind of magic

To Yededaia. He always believes that I know everything.

To Edilma Cotapo, we are one step closer...

To my Friends, the happy few.

And to Rex and Max, for being unconditional from the very beginning.

Kennie Clark



CATHOLIC UNIVERSITY OF SANTIAGO DE GUAYAQUIL

FACULTY OF ARTS AND HUMANITIES SCHOOL OF ENGLISH LANGUAGE

GRADE

Sara Rivadeneira Enríquez, MSc.

Project Advisor

Table of Contents

Abstract	xii
1. Introduction	1
1.1. Topic and justification	1
2. Problem	4
2.1. Statement of the Problem	4
2.2. Research Questions.....	5
2.3. General and Specific Objectives.....	5
2.3.1. General Objective	5
2.3.2. Specific Objectives	5
2.4. Conceptual Framework.....	5
2.4.1. The Company	6
2.4.2. Internatinal Standards	6
2.4.2.1. ISO Certification	6
2.4.2.2. BASC	7
2.4.2.3. Conformité Européenne Directives.....	7
2.5. Linguistic devices and Translation	7
2.5.1. Translation	7
2.5.2. Annotated Translation	7
2.5.3. Borrowing.....	8
2.5.4. Semiotics	8
2.5.5. Pragmatics.....	8
2.5.6. Register	8
2.5.7. Semantics	9
2.6. Safety on machine operation.....	9
2.6.1. Safe work procedures	10
2.6.2. Machine Hazard Control	10
2.6.3. Implementing Control measures	10
2.6.4. Keeping Documents and Records	10
2.7. Methodological approach.....	10
2.8. Research instruments	11
2.9. Findings	12
2.10. Conclusion and recommendations	24
3. Description of the product.....	26
4. References	27
5. Appendix	29

1. ETERNA PE1620SA-Extra manual (ST - English)	30
2. ETERNA PE1620SA-Extra manual (TT - Spanish)	31
3. Interview with Jimmy Garcia (English)	32
4. Photos of Eterna Machine.	35
Documentation about ETERNA Machine - Specifications.....	39

TABLE OF FIGURES (TABLES)

Table 1 Descriptors found in ST and TT	11
Table 2 Perfect Semantic Equivalence terms.....	18
Table 3 Intersemiotic References to ST	18
Table 4 ST and TT Terminological bank with semantic equivalences	22

TABLE OF FIGURES (PICTURES)

Picture 1 ETERNA Diecutter flatbed machine	35
Picture 2 Section for trimming cardboard waste material	35
Picture 3: Machine at PROCARSA – Waste disposal section.....	36
Picture 4: Batch Counter Belt.....	37
Picture 5: Machine Operator carrying a wooden ward blueprint for the die cutter	37
Picture 6: Machine at PROCARSA -Delivery and In feeder	38

ABSTRACT

This annotated translation is an attempt to provide a rendering for a manual based on a product from a die/cutting machine manufacturer so that PROCARSA, the company I will be referring as “The Client” or merely “PROCARSA”, could be able to aspire to comply with international standards while safeguarding the safety-in-the-workplace culture for its machine operators in an everyday working environment. The main points are to address the problematic of having documentation at hand and adequately organized and if need be translated to all languages the company uses for its procedures so that the client may be eligible to be accredited by an quality assurance certification body such as ISO, BASC, CE directives etc. Another aim is to ensure that such documentation addresses issues regarding safety in the workplace for its quality and accuracy can heavily impact the outcome of an unforeseen situation where the how-to of the matter is available to be used properly. In addition to this, this work accesses the limitations of translating such document regardless of the purpose of it. Through a linguistic perspective, several aspects of the rendering itself are disclosed to grant a guiding light to others facing the same quandary. Consequently the results show that the need for documentation, updated, faithful and language-ready is paramount not only to comply with international standards but also to give personnel the tools that may, in any unforeseen occurrence of a problem, help them find the solution based on the manufacturer’s know-how and avoid risks and potentially harmful situations apropos of the machine.

Keywords: *annotated translation, flatbed die cutter, ETERNA, linguistics, rendering, ISO, Standards*

1. INTRODUCTION

1.1. TOPIC AND JUSTIFICATION

In a globalized world among all the statutory laws and regulations that coexist in a corporate environment, companies strive to make the better products and to offer higher quality services. For the close client-service relations, client satisfaction is paramount for it will determine the continuity of that company that offers services to maintain a constant flow of work. For a company that manufactures a given product, the quality as well as the product itself are key for the company's prevalence in the market. Both types need to concur on a fixed set of guidelines and regulations that will provide a clearer path to success.

These statutes are tightly bound to quality assurance. They are standards. When a company wants to conform to these standards, they are required to comply with a wide variety of requirements. Organizations such as the Conformité Européenne, International Standards Organization (ISO), World BASC Organization (Business Alliance for Secure commerce) and other European institutions have authority in the standardization and eligibility of processes. Several of these requirements are met to ensure that the process, product or service comply with the necessary provisions that international bodies demand.

As the goal of a company relies on offering the best solution and integral processes, obtaining a certification from an international body, the odds increase when it comes to signing a contract with a client and being selected from among many others. Part of the process to comply with high standards is the availability of appropriate documentation; i.e., instruction manuals, user guides, software implementation procedures, etc. for each of the products the company offers.

In the realm of documentation, it will be necessary to provide the aforementioned requirements in order to claim the certifications needed. The company will benefit from these quality assurances and thus the product or service itself will have an increase in demand.

In companies where products rely heavily on machines to do the heavy work or the necessary work to produce a product, the maintenance and operation of the machines are paramount to the company. Alongside comes documentation; in this case, the most common type are instructions manuals and user guides. From the two types, instruction manual are the most sought after document to which employees recur in the case of an emergency or faulty operation in order to solve minor issues or general less superfluous machine defects.

By empiricism, one can muster the art and science of the operation of a machine. Up to some point, it works for most cases. There is, however, the imperative need to consult the manual in case something unexpected occurs. All machinery comes with a manual and generally, it is only on the language of manufacturing. It could also have been translated into a language of a target market's country. When a manual comes in the language of the country of manufacturing (L1,) rather than the country of commercialization or where the machine will be used (L2,) limitations arise. The feasible option, which by all accounts can be expressed on a simple phrase: "I will check the manual," does not simply provide an alternative. Even if the manual is checked, the language used by the operators will very likely be different from that of the manual. This makes it very difficult to use the information contained in the manual and put it in practice. Even when some terminology is repeated and used interchangeably to represent and express certain concepts, the specificities of the manual itself may not reflect the author's intent.

The Annotated translation of ETERNA PE1620SA-Extra manual for PROCARSA is crucial for the company to align to one of the aforementioned quality standards. In this, case it is required for the Conformité Européenne Directives in Article 10 of the CE Marking Directives for the EC Declaration of Conformity, paragraph 2. This statute demands the managing of documents pertaining to the products (or machines) used in the process of making a product or used as the product if the aim is to be used or commercialized in the European Economic Area (EEA.)

Such intervention in quality standards and quality assurance certifications have led the author to suggest and apply the translation of one of

the machines used in PROCARSA (ETERNA PE1620SA,) as to provide a usable guide and instruction manual for such machine and help comply with the standards that the company is meant to follow.

PROCARSA's current position in the packaging and die-cutting market leading edge alongside with the group to which it belongs (SURPAPEL Group) and its most immediate goals incur on being part of certification such as BASC Certification for businesses in Europe and worldwide.

2. PROBLEM

2.1. STATEMENT OF THE PROBLEM

The problematic for this research document has been aimed towards the evidence of an existing document that may aid in the process for international accreditation given by foreign quality assurance organizations. Within the documentation in the company PROCARSA which deals with packaging material and box manufacturing in the die-cutting market, an absence of the instruction manual for ETERNA PE1620SA-Extra manual for PROCARSA was evidenced, and thus the main goal of this work is justified.

For many companies the lack of documentation is palpable when audits occur, this leads to a non-conformity situation in which the fault is documented and change and improvement are required.

In SURPAPEL group, one of its subsidiaries is PROCARSA, a leading company in the die-cutting manufacturing and packaging business in Ecuador. This company attempts to comply with international regulations in order to increase the competitive ambience even on international soil. In order to do this, a restructuring in their documentation department had to be done and among all the reparations, so to speak, it is the revision and update of all the manuals that they have had since they received the machinery necessary for the die-cutting business.

The ETERNA PE1620SA-Extra manual was selected by the company's board as one of the manuals whose translation will yield positive impact not only in the processes performed by the company, but also in the occupational safety and health of the workforce. Its translation also aims to help the company comply with another requirement for the European Certification they are pursuing.

2.2. RESEARCH QUESTIONS

Up to what extent can the translation of ETERNA PE1620SA-Extra manual for PROCARSA contribute to the restructuring of the company's documentation to comply with International Standards?

- What intertextual reference could contribute to the rendering of a usable instruction manual?
- What are the most salient features of the Source Text?
- What are the main translation problems faced by the translator?
- How will translation problems be tackled?

2.3. GENERAL AND SPECIFIC OBJECTIVES

2.3.1. GENERAL OBJECTIVE

Apply terminological research to render the translation of the ETERNA PE1620SA-Extra manual for PROCARSA to ensure compliance with international regulations.

2.3.2. SPECIFIC OBJECTIVES

- Identify the required terminological field and the scope of the translation itself.
- Describe the main pitfalls in technical translation and posit some feasible outcomes for them.
- Group and label annotations according to their linguistic characteristics (morphological, semantic, pragmatic, characteristics)

2.4. CONCEPTUAL FRAMEWORK

In the following lines, key concepts as well as background information about the company PROCARSA and SURPAPEL Group are given. Moreover, information about legal requirements and international standards compliance are to be disclosed as to give a clearer perspective of the company's aims.

The different theories that encompass translation techniques for the specific kind of documentation described in this work are specified as well.

2.4.1. THE COMPANY

PROCARSA and other subsidiaries from SURPAPEL Group are entities devoted to the design, production and commercialization of packaging solutions with cutting-edge technology. Among their products there are Paper, Corrugated board corrugates boards for pre and post print. Their business is the sustainable development of the company and continuous improvement and has its basis on key values and ideals such as having the client as active asset and strategic partner along the assembly line. In addition, they focus on the integral quality of their products, processes and services in order to ensure timely deliveries.

The company focuses on the development of the professionals it hires and converges its company values, competencies, motivation and respects to cope with the unalienable Human Rights. (Grupo SURPAPEL, n.d.)

Nowadays, PROCARSA's involvement in the international Standards certification has aligned its path towards Lean Philosophy, ISO 900 and BASC. These alignments are now embedded as part of the quality policy of the company and processes have to be in compliance with these guidelines.

2.4.2. INTERNATIONAL STANDARDS

2.4.2.1. ISO CERTIFICATION

ISO Certifications are validations and assurances in the form of documents that are granted to companies or institutions that decide to align to the ISO guidelines and regulations. External companies are the ones that issue certifications as proof of compliance with the ISO requirements. ISO Designs and establishes the protocols for virtually every procedure, manufacturing process, or product available in the market. (ISO, 2015)

2.4.2.2. BASC

Business Alliance for Secure Commerce – BASC, refers to an international business alliance that supports and promotes secure international trade in cooperation with governments and international organizations. The processes examined by BASC are manufacturing processes emphasizing the creation of security –conscious environment throughout the supply chain. (BASC, 2005)

2.4.2.3. CONFORMITÉ EUROPÉENNE DIRECTIVES

Is an assurance term that indicates when a product complies with the essential requirements of the relevant European health, safety and environmental protection legislation, in practice by several of the Product Directives. (Wellkang Tech Consulting, 2011)

2.5. LINGUISTIC DEVICES AND TRANSLATION

2.5.1. TRANSLATION

According to Roger T. Bell:

“(...) the need for a scientific mode in developing translation process not discarding the importance of linguistics. (...) both the technique and knowledge of the text is important. Translation is not only a process of recycling the original text but also it is a process wherein recreation takes place.”

This statement communicates that for a translator, translation is not a process in which words have to be placed in a realm of another language, but several other factors play a role in conveying the information that best suits the product.

2.5.2. ANNOTATED TRANSLATION

An annotated translation is a product of a rendering where the specificities found in regards to the several misconceptions in ST to TT are described after having been dealt with. An annotated translation makes use of footnotes but not sparingly. (Phil, 2014)

2.5.3. BORROWING

Borrowing is a direct translation techniques that is used when words can be directly taken from the ST to the TT. They are sometimes printed in italics when they are considered foreign. Some examples are: *résumé* from French language, *hamburger* or *kindergartner* from the German, *bandana*, *musk* and *sugar* from the Sanskrit. (Bosco, 2015)

2.5.4. SEMIOTICS

In 1938, Charles Morris defined Semiotics as the use of signs governed by syntactic, semantics and pragmatics rules. Following this concept, signs play a crucial role for the transmission and encoding of messages in the communication process.

Symbols as well as signs can be interpreted by the party who receives the message as well as the party who sends the message. When a code is established both parties need not the use of words to understand the symbol and thus the message gets across.

2.5.5. PRAGMATICS

According to J. L. Austin when using language, people do not just talk or write to one another but rather they perform actions, they do things, usually in contexts that combine linguistics and non-linguistics elements, part of the context in which they communicate consisting of the knowledge, beliefs and assumptions of all concerned.

Based on this, pragmatics focus on the study of what the user intends to communicate and this can be connected to the rendering because of the imperative need of technical vocabulary used in instructions.

2.5.6. REGISTER

According to Halliday, Registers are ways of saying different things; they reflect social processes such as division of labor, specialty, contexts, content areas and specific activities.

He also states that a register can be defined as the configuration of semantic resources that the member of a culture typically associates with a situation type. It is the meaning potential that is accessible in a given situation and the register associated with it can be described to varying degrees of specificity, the existence of register is in fact an everyday experience. (Solano-Flores, 2006)

2.5.7.SEMANTICS

According to Richmond H. Thomason, Semantics is the study of the meaning of linguistic expressions. The language can be a natural language, such as English or Navajo, or an artificial language, like a computer programming language. Meaning in natural languages is mainly studied by linguists. In fact, semantics is one of the main branches of contemporary linguistics. Theoretical computer scientists and logicians think about artificial languages.

In some areas of computer science, these divisions are crossed. In machine translation, for instance, computer scientists may want to relate natural language texts to abstract representations of their meanings; to do this, they have to design artificial languages for representing meanings. (Thomason, 2012)

2.6. SAFETY ON MACHINE OPERATION

In a company, specifically in a manufacturing product company, operators face daily hazards when doing their jobs. Machine operation is among the occupation for which Best Practices to avoid the harmful impact of a person's physical health has been issued. (Ministry of Business, 2013)

Among the myriad considerations that companies have to take into account when providing safety to their work force are the compliance with International Safety regulations, providing adequate training to those in charge of the operation of the machinery, and to document new procedures and update manuals.

2.6.1. SAFE WORK PROCEDURES

Work procedures have to be in relation to machinery and plant and address issues such as keeping an eye on guarding procedures and make sure workers do not bypass them, thorough instructions for cleaning repairing, maintenance and emergency procedures. (Ministry of Business, 2013)

2.6.2. MACHINE HAZARD CONTROL

Hazards in operation of machinery can be found when operators get caught, entangled or injured by machinery. Among the factors that are to be reflected upon are: visibility, orientation and to anticipate work practices. All these are aimed to provide a more secure environment. (Ministry of Business, 2013)

2.6.3. IMPLEMENTING CONTROL MEASURES

Effective operation can be guaranteed by following guidelines that address arrangements for appropriate guarding installments, arrangements for provisions, instructions and supervisions, maintenance for machines and safeguards, effective reporting of malfunctioning with machinery. (Ministry of Business, 2013)

2.6.4. KEEPING DOCUMENTS AND RECORDS

Effective regulations require keeping records updated on every modification made, this action can ensure the safety of the operators because it demonstrates compliance with legal obligations and the level of documentation should be appropriate to the level of risk (Ministry of Business, 2013)

2.7. METHODOLOGICAL APPROACH

The methodology selected for this project was based on the descriptive reference to an established Source Text in English and a projected Target Text in Spanish together with the strategies undertaken to render it and the analysis of cross linguistic equivalence when facing important decisions connected to the outcome of the project: the product.

2.8. RESEARCH INSTRUMENTS

For the development of this annotated translation project it was necessary to design an analysis table so as to establish guidelines regarding the items to be annotated. Salient features considering the nature of the document to be translated and annotated were seen as descriptors to the process.

The first point of analysis was the document field, which has been established as technical.

Table 1 Descriptors found in ST and TT

Descriptors	ST	TT
D1. Complex words (words often used ad-hoc in order to convey a defined and prompt meaning to be used in a certain situation)	x	x
D2. Borrowings (words that cannot be fully translated into the TT and need to be used as is in the ST for intended purposes)	x	x
D3. PSE (Perfect semantic equivalences) – If possible a list of all PSEs will be listed to demonstrate that in technical translation words have to be universally equivalent in order to accurately provide information.	x	x
D4. Semiotics – Intersemiotics: For this type of technical translation several symbols and drawings or sketches used in the die-cutting field that can transcend the barrier of languages and still converge the intended meaning.	x	x
D5. Terminological bank (a comprehensible list of words used in the die-cutting business and/or documentation alike)	x	x

2.9. FINDINGS

Based on the five descriptors established, the ST and TT were analyzed and relevant contributions to the technical translation field are described herein.

It is worth noting that when a Text1 has been translated into a Text2 and someone attempts to reverse-translate it, then the product will necessarily be a Text3 and not Text1. These are common misconceptions when translating documents. The performer or performers of the translated texts may not be the same person and thus do not have the same mind to render the same ST.

For the Pre transfer stage, a formal interview (See Appendix # 3 - Interview) was made on the staff of PROCARSA on October 2014. The objective of the interview was to identify the amount of operators of ETERNA Machine and machines alike who speak English, or effectively use it for their daily activities; the interview was also aimed at finding out the amount of people who use English unconsciously when they operate a machine only because experience granted them with the expertise for such operations. The Interview inquires whether or not the staff considered useful to know the language (SL: English) in case of an unforeseen event that would require them to actually check for a solution or a procedure based on instructions from the manufacturer.

The information obtained from the interview revealed that only 10% of the staff (30 operators) know English at a functional level, i.e. to a level in which they can communicate effectively but in a limited environment. 90% of the staff only used English (technical English) in order to operate machinery with very basic instructions such as ON and OFF or dispatch or load procedures. 70% of the staff thought that the likeliness of an event where they would be required to solve a problem by revising actual manufacturer's documentation was non-existent. Response from Mr. Garcia were based on the fact that years of experience cover all occurrences where immediate intervention of expert operators is deemed as necessary. (Jimmy Garcia, 2014) This; however, represents a faulty assumption and if this argument faces international

Standards it will be prone to disapproval. Thus justifying the need for the rendering of the manual.

By using this translation, operators would not have to rely solely on their experience, which is on itself a limitation to the actual capacity for solving problems, but will now have a source where they can get the necessary information upon which apply their experience for working out a solution for a unforeseen malfunctioning.

Some semantic instances can be clearly identified at the beginning of the translation. In the title of the document, clarification is needed for people to know that the document is a manual intended for a specific product besides the model for classification purposes. As the ST is a translation from Chinese to English, it has losses that do not have to be accounted for because the target audience are machine operators and it may have been overlook as long as there is one provider, "ETERNA"; however, as the company works with other brands as well and owns other types of machines, the compensation was made. (See Appendix 1 and 2).

In the rendering the descriptors established on Table #1 portray an outline for the linguistic approach given to this work. For a better comprehension of the aforementioned descriptors, they will be labeled and referenced in the following lines. The annotations follow the pattern of ST being English and the TT being (Globalized) Spanish.

D1. Complex words (words often used ad-hoc in order to convey a defined and prompt meaning to be used in a certain situation)

The words listed below do not have a defined meaning on their own, these are often created to convey meaning in a certain situation, as in the case of this work, they allow for the terminology needed in order to label the mechanical parts of a machine that are named after the use for which they were created. Furthermore, patents apply to words and whole inventions regarding mechanical parts of machines, this is also a limitation that can be tackled by

rendering complex words and terms. (United States. Patent Office, 1872). The references herein are present in the Original ST manual (See Appendix 1)

- **Die cutter (ST / n.):** (ST Pages # 1-6, 1-7, 5-12)

TT: *Cortadora de Moldes. (Maquina Troqueladora)*

The machine used to cut the design patterns made on blueprint onto cardboard to render the prior stage in the production of a box.

- **Warp Board (ST / n.):** (ST Pages # 2, 9-3)

TT: *Tablero de Urdimbre. (Tablero de Deformación)*

Warp boards are linked to the machine usage for they contain the patterns as if they were used in a knitting machine to make carvings in the cardboard. It allows warping of the corrugated cardboard.

- **Recouping wrench (ST / n.):** (ST Pages # 2-3)

TT: *Llave de recuperación. (Manivela para retornar a la posición de descanso)*

This wrench is used to set the device in a levered position from any final position to the initial position or recouping position (rest position). This state indicates the stepping down of a process of the machine.

- **Die (ST / n.):** (ST Pages # 3-2, 5-12, 6-1, 6-3, 6-5, 6-9)

TT: *Dado (Troquel / Dado para troquelado)*

A die or troquel is a perforated block through which metal or plastic is drawn or extruded for shaping. It is used to for the warping in the corrugated cardboard.

- **Die chase (ST / n.):** (ST Pages # 6-9, 6-10, 9-4)

TT: *Mesa para troquelado (Mesa para troquelado)*

The die chase is a rectangular steel or iron frame in which letterpress matter is locked (as for printing), in this case for warping the corrugated cardboard and for cutting using the die cutter.

- **Crank Shaft (ST / n.):** (ST Pages # 11-3, 11-4)

TT: *cigüeñal (cigüeñal)*

A shaft consisting of a series of cranks and crankpins to which the connecting rods of an engine are attached. It belongs to the orchestra of parts in the ETERNA machine.

- **Oil Nipple (ST / n.):** (ST Pages # 11-2)

TT: *engrasador o boquilla roscada. (Racores para entrada de aceite)*

An oil nipple is a small projection through which oil or grease is injected into machinery.

- **Jogger / Jogging (ST / n.):** (ST Pages # 1-2, 1-4, 1-5, 8-5)

TT: *basculador / movimiento (Basculador / Movimiento del basculador)*

The joggers are devices in the ETERNA Machine help the feeding to the material to be placed into the machine and control the speed at which the process is carried out (jogging).

- **Jog feed (ST / v.):** (ST Pages # 1-2, 1-4, 1-5, 8-5)

TT: *alimentación por movimiento (to align the edges of piled sheets of corrugated cardboard by hitting or shaking against a flat surface)*

To jog feed in this case is meant to align the edges of piled sheets of corrugated cardboard by hitting or shaking against a flat surface

- **Trims (ST / n.):** (ST Pages # 7-5, 7-7, 7-8)

TT: *reguladores (reguladores de corte)*

Trims belong to the series of devices in the Stripper section of the machine that are in charge of disposing the excess of material by cutting the extra material from the final product.

- **Real Line and Broken Line (ST / n.):** (ST Pages # 1-11, 9-2, 8-5, 9-5)

TT: *Línea Real y Línea Rota (Línea Continua y Línea Entrecortada)*

Patterns displayed by the PLC in the ETERNA machine. It indicates the sheet pusher is operative (real line) or inoperative (broken line).

- **Filler (ST / n.):** (ST Pages # 6-19, 6-22)

TT: *Piezas de relleno*

Specific pieces in the machine that serve as space occupying bodies for a determined location in the internal mechanisms of the die cutter and other machines.

- **Dogbone Connection (ST / n.):** (ST Pages # 5-12)

TT: *Conexión de Hueso de Perro*

Selectively trimming a portion of a beam allows connection strength to exceed beam strength without the need to develop a stronger connection (Modern Steel Construction, 1996)

D2. Borrowings (words that cannot be fully translated into the TT and need to be used as is in the ST for intended purposes)

During the rendering borrowings were found that are commonly used by machine operators and interchangeably applied to the same semantic equivalence. No favorable response was obtained on where the borrowing came from or why it bore such name. None except for PLC, which was briefly explained by Mr. Garcia in the interview.

- **Relay (ST / n.):** (ST Pages # 1-19)

TT: *Interchangeably used as “relé” and written also as “relay”*

Pronounced /re'le/ (*Relé o relevador / dispositivo mecánico electrónico*)

An electromagnetic device for remote or automatic control that is actuated by variation in conditions of an electric circuit and that operates in turn other devices (as switches) in the same or a different circuit.

- **PLC (ST / n.):** (ST Pages # 2-2, 1-18, 10-21)

TT: *PLC (Programmable Logic Controllers) - (Controladores Lógicos Programables)*

Basically a relay is an electrically powered switch. A relay has two main parts, a coil and switch contacts, normally several separate sets of switch contacts. (Howard Hendricks, 2002)

- **OS and OOS (ST / n.):** (ST Pages # 1-3, 1-4)

TT: *OS lay and OOS (Operator Side) - (Operator Opposite Side)*

Abbreviations to indicate the place where the switches are in respect to the operator's position.

D3. PSE (Perfect semantic equivalences) – If possible a detail of all PSEs will be listed to demonstrate that in technical translation words have to be universally equivalent in order to accurately provide information.

The following words belong to a classification known as Perfect Semantic Equivalence where in the ST as in the TT, the terms are equivalent without variations in semantics.

Table 2 Perfect Semantic Equivalence terms





ST – English	TT – Spanish
Dogbone Connection	Conexión de Hueso de Perro
Jogger	Basculador
crank shaft	Cigüeñal
corrugated cardboard	Cartón corrugado
ratchet	Trinquete
pawl	Gatillo
Kraft paper	Papel de embalaje
Stepped cam	Leva de distribución

D4. Semiotics – Intersemiotics: For this type of technical translation several symbols and drawings or sketches used in the die-cutting field that can transcend the barrier of languages and still converge the intended meaning.

The following Table shows some graphics and designs that are aimed towards transmitting a universally accepted message. Symbols that amount to complete ideas or actions are part of the intersemiotic realm.

Table 3 Intersemiotic References to ST

	<p>Page # 1-18 from ST Conveys the ON / OFF alternative and thus the power switch is implied.</p>
---	---

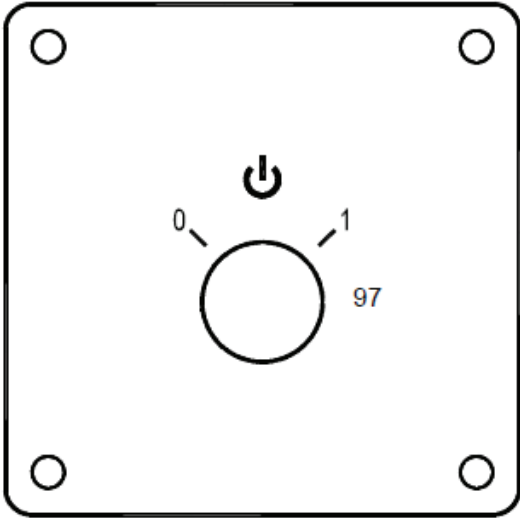
 <p>95</p>	<p>Page # 1-21 from ST Conveys stripper section of the machine due to the little protuberances at the bottom as if they were teeth.</p>
 <p>57</p>	<p>Page # 1-9 from ST Conveys changes in speed for the conveyor and so the jogging movement is applied.</p>
 <p>43</p>	<p>Page # 1-6 from ST Conveys the concept of Potentiometer in order to change the dial accordingly.</p>
 <p>83</p>	<p>Page # 1-14 from ST Conveys the switching of position (up and down) of the control delivery main pallet</p>
 <p>97</p>	<p>Page # 1-22 from ST A combination of these symbols conveys a much broader idea. In this case is the machine stop main switch</p>

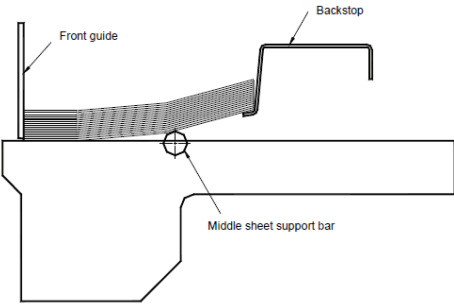
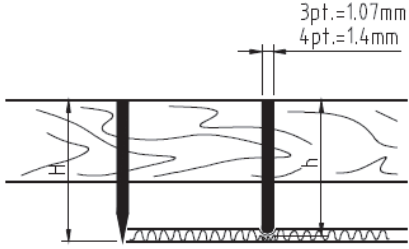
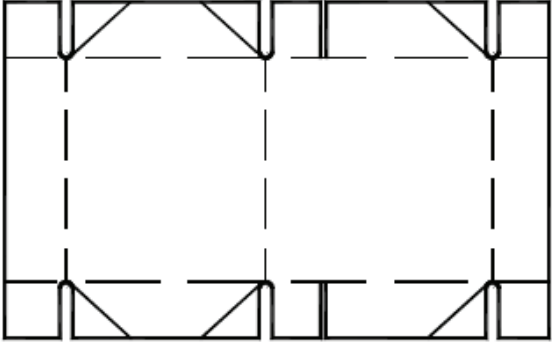
	<p>Page # 5-10 from ST</p> <p>This design conveys the lateral perspective for the guides and the sheets of corrugated cardboard fed into the machine.</p>
	<p>Page # 6-7 from ST</p> <p>This part of a blueprint for the diecutting stage shows the SI units of measurements applied as it is an international convention for measurements.</p>
 <p style="text-align: center;">Fig. 6.13 B. 4-6 glued corner box</p>	<p>Page # 6-15 from ST</p> <p>The corrugated cardboard and the sections that are represented by line segments are common in the diecutting business for they give an idea of how the box will look like after creasing.</p>

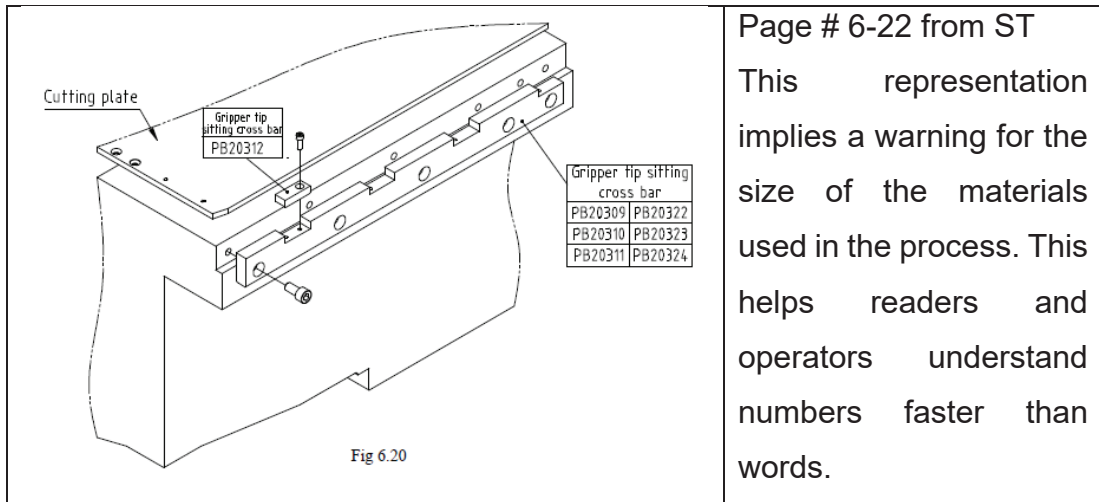

Page # 6-22 from ST

This representation implies a warning for the size of the materials used in the process. This helps readers and operators understand numbers faster than words.

D5. Terminological bank (a comprehensible list of words used in the die-cutting business and/or documentation alike)

A list of all the terms found in the ST that belong to the die cutting process and die cutting business. Alongside this are very brief descriptions or equivalences for the terms

Table 4 ST and TT Terminological bank with semantic equivalences

ST – English	ST – Spanish
Die cutter	Troqueladora
warp board	Tablero de deformación
warpness	deformación
recouping wrench	Llave para posición de descanso
recouping position	Posición de Descanso
die	Troquel
oil nipple	Racores para entrada de aceite
jogger	basculador
die chase	Mesa de troquelado
jog feed	Alimentación por movimiento
crank shaft	cigüeñal
jogging	Movimiento de basculador
back-stopper	tapón
toggle system	Sistema de cambios (alternador)
platen	rodillo
chase	Mesa para troquelar
gripper	Pinza de cogida
gripper bar	Barra de sujeción
trims	Reguladores de corte
spring	resorte
clogging	atascamiento
conveyor	Cinta transportadora
corrugated cardboard	Cartón corrugado
pin	Perno
bolt	tornillo
drive	accionamiento
back-stopper	tapón
tool	Cuchilla
oil line	Tubería de aceite
lengthwise	longitudinalmente
real line	Línea continua
Broken line	Línea entrecortada
filler	Pieza de relleno
tip	punta
straps	correas
centerline	eje
notch	muesca
toggles	alternadores
wheel crank	Manivela de timón

declutch	Quitar el embrague
ratchet	trinquete
spanner	Llave inglesa
crease	doble
pallet	Bandeja de carga
stripper	separador
sprocket	Rueda de espigas
pawl	gatillo
shaft	eje
stroke	recorrido
actuate	Accionar o mover
in feed	Alimentación de entrada
photocells	Células fotoeléctricas
delivery back stopper and front edge stripper	Tapón de distribución y separador de borde frontal
pallet	Bandeja de carga
PLC	Programmable Logic Controllers
OS	operator side
OOS	Operator opposite side
Cam shaft	Árbol de leva
Kraft paper	Papel de embalaje
Dog bone connection	Conexión de hueso de perro
Housing	carcasa
Bearing	apoyo
Stepped cam	Leva de distribución
Holder	contenedor
Shims	Nivelar con una pieza de material un calce
beam	viga

2.10. CONCLUSION AND RECOMMENDATIONS

At the post transfer stage, the translator finds the limitation and the scope of the work done. Alongside this, the person required to carry out the rendering should have some general knowledge of the subject matter of the job; this, however, is not always the case. In order to solve this issue the company or client should provide training on the subject. This would give the translator a better perspective and a far more useful set of tools based on new experiences on how to deal with the rendering.

Another point that needs to be taken into consideration is that of the way the rendering has to be done. In order to meet a deadline, certain methods and decisions need to be taken regarding the management of time.

This rendering amounted to a time frame of several weeks. The given deadline was only a month so a constant work and very precise actions were taken. They included staying up until late hours of the night, rechecking pages and graphics instead of letters and other dealings necessary to conclude this Project. No breaks were taken for the duration of the rendering, consequently, constant work is required.

The translator's own Schedule is mandatory in order to achieve a degree of effectiveness and avoid unnecessary time waste. A set of materials be them tangible or intangible need to be established beforehand so that the resource most valuable is preserved, time is essential and its administration is paramount to meet deadlines.

The translator often faces several problems with the document at hand before rendering the product. In this case, the product had to be exactly like the original because it was a manual of a machine that will be operated by people and accuracy and precision in instructions is vital for the correct working environment and safety compliant procedures of the machine. To achieve an adequate workflow, the translator needs to be given proper documentation regarding the ST. In this project the document for the ST was in a pdf file encoded with an old version of Adobe Acrobat. A document like this is complex when attempting to go through the pre transfer process due to the actual format equivalences alongside the version of the word processing software used.

Conclusively, the company or client should grant flexible options for the ST so that the rendering could be more feasible in digital format when needed. For this project, the digital format was key to preserve the structure, nature and intent of the manual for the ETERNA Machine.

3. DESCRIPTION OF THE PRODUCT

The ETERNA PE1620SA-Extra manual is a technical document that is used by operators in PROCARSA S.A. a company in the die-cutting business. This manual is divided into eleven chapters and the digital version is in portable document format (*.pdf) and its encoding is prior to Adobe Acrobat 9.0. It is worth mentioning that Adobe Acrobat XI was used for the rendering process from the pre transfer through the post transfer.

The ETERNA PE1620SA-Extra manual used as a ST was found in a foreign language other than English as the original language used in the manufacturing process. This limitation gives way to errors and or economical factor in the usage of words to describe things and processes. The language of manufacturing was Chinese, and from that, English became the TT2 (assuming Chinese was ST2). Between these languages there are a myriad of losses in translation but they will not be described in this work for the rendering documents cannot be held accountable.

An interview is also part of the process for the rendering of the product related to the transfer for the ETERNA manual from SL English to TL Spanish. The interview attempts to show a more accurate perspective of the amount of workers depending on the necessity for the use of the manual in the company. The manual originally is in English, roughly translated from Chinese. And the TL is Spanish. The interview will present the need for this translation and the language used is Spanish. The target of the interview is the chief of department of the operation for die cutting machines at PROCARSA, Jimmy Garcia.

The original document contains instructions in English and diagrams portraying instructions or often directed towards a specific action. There are full-color pictures for some of the parts of the machine and the blueprints for the design of die cutters remain unchanged except for the numbers and units based on the SI (Système International d'Unités) (BIPM, 2014)

4. REFERENCES

- BASC. (2005). *General Information*. Retrieved January 25, 2015, from World BASC Organization: <http://www.wbasco.org/index-eng.htm>
- BIPM. (2014, 10 13). *Measurement units: the SI*. Retrieved from BIPM - Bureau International des Poids et Mesures: <http://www.bipm.org/en/measurement-units/>
- Bosco, G. (2015). *Translation Techniques*. Retrieved from Interpro Translation Solutions: <http://www.interproinc.com/blog/translation-techniques>
- EKOS Negocios. (n.d.). *Productora Cartonera S.A. | Informacion de empresas de Ecuador*. Retrieved September 16, 2013, from EKOS - EL PORTAL DE NEGOCIOS DEL ECUADOR: <http://www.ekosnegocios.com/empresas/empresas.aspx?idE=114>
- EMIS. (n.d.). *Productora Cartonera S.A. | Ecuador | Perfil de Compañía*. Retrieved September 16, 2013, from EMIS | Emerging Markets Information Service: http://www.securities.com/Public/company-profile/EC/Productora_Cartonera_SA_es_3398908.html
- Grupo SURPAPEL. (n.d.). *Acerca de Nosotros*. Retrieved December 4, 2014, from Grupo SURPAPEL - The best packaging solutions: http://www.gruposurpapel.com/index.php?option=com_content&view=category&layout=blog&id=34&Itemid=258
- Howard Hendricks. (2002). *The Concise PLC History*. Retrieved October 19, 2014, from http://www.machine-information-systems.com/PLC_History.html
- ISO. (2015). *Certification - ISO*. Retrieved January 25, 2015, from ISO: <http://www.iso.org/iso/home/standards/certification.htm>
- Jimmy Garcia, M. (2014, April 10). Entrevista para recolección de datos para Traducción de Documentos de PROCARSA. (K. Clark, Interviewer) Guayaquil, Guayas, Ecuador.
- Ministry of Business, I. a. (2013, June). *Best Practices for the Safe Use of Machinery*. Wellington, New Zealand. Retrieved December 12, 2014, from www.mbie.govt.nz
- Modern Steel Construction. (1996, August). *The Dogbone connection Part II*.
- Phil, M. (2014, April 03). *M. Phil in Literary Translation - Annotated Translation*. Retrieved from Trinity College Dublin: https://www.tcd.ie/langs-lits-cultures/postgraduate/literary_translation/annotatedtranslation.php
- Solano-Flores, G. (2006). Language, Dialect, and Register: Sociolinguistics and the Estimation of Measurements Error in the Testing of ELL. *Teachers College Records*, p. 26.
- Thomason, R. H. (2012, March 27). *What is Semantics?* Retrieved January 25, 2015, from University of Michigan: <http://web.eecs.umich.edu/~rthomaso/documents/general/what-is-semantics.html>
- United States. Patent Office. (1872). *Annual report of the Commissioner of Patents*. U.S. Government Printing Office. Retrieved January 10, 2015, from

https://books.google.com.ec/books?id=LZLCLjCHZUIC&dq=recouping+machine&source=gbs_navlinks_s

Wellkang Tech Consulting. (2011). *What is CE marking (CE Mark)?* Retrieved January 25, 2015, from CE-Marking: <http://www.ce-marking.org/what-is-ce-marking.html>

5. APPENDIX

In the following pages evidence of the aforementioned cross-referenced materials is present.

First the original ST in SL English as is from the original pdf file used. The next appendix is the actual rendering marked as the Final product for the translation.

Then follows the Interview with Jimmy Garcia, where it is stated that the need for a rendering of ETERNA die cutting machine is requested from PROCARSA.

Photos obtained from a visit to PROCARSA are shown and staff operators can be evidenced.

1. ETERNA PE1620SA-EXTRA MANUAL (ST - ENGLISH)

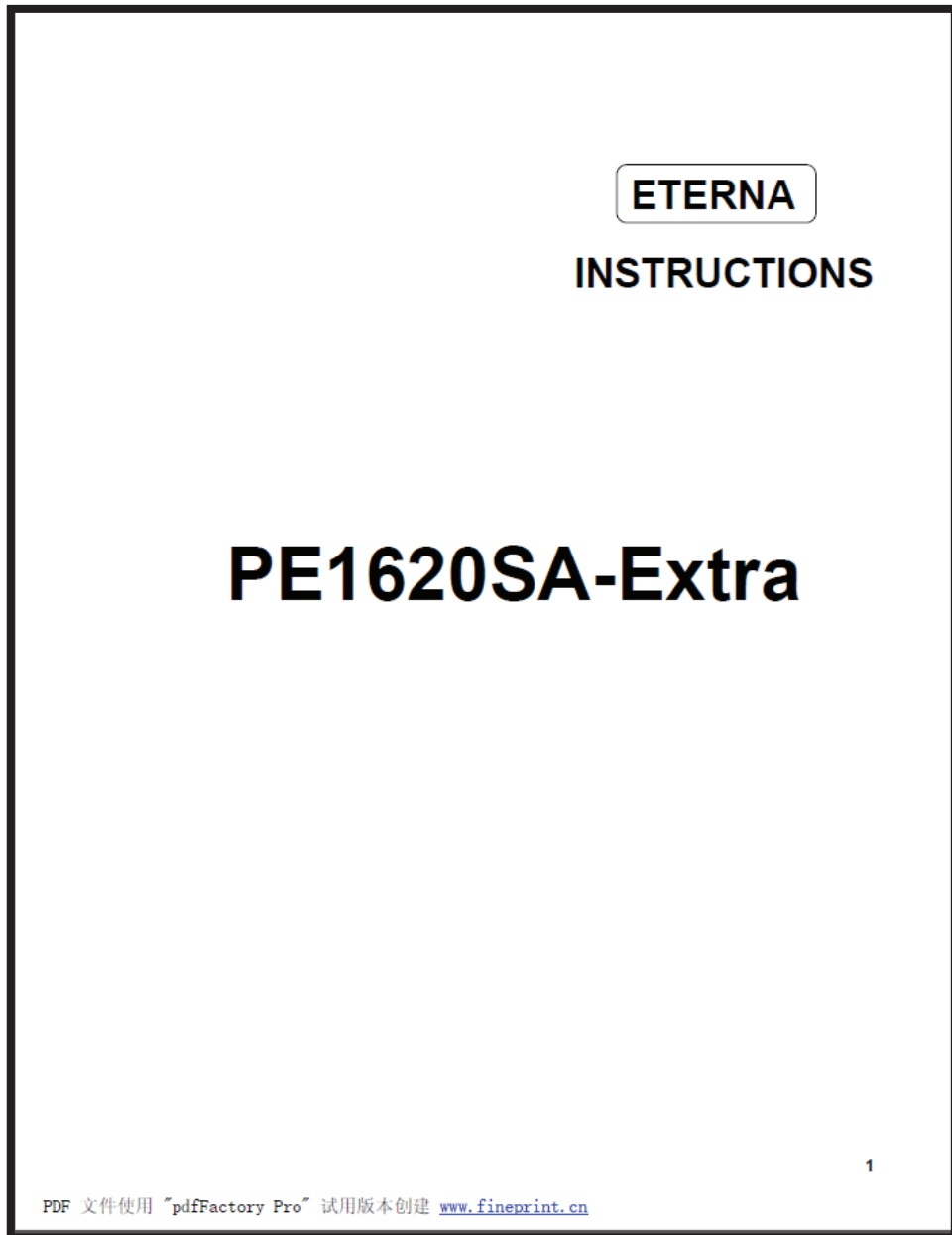

ETERNA

INSTRUCTIONS

PE1620SA-Extra

INDEX

1. General operation control
 - A. Operation Panel – Feeder. Symbol 25-35
 - B. Operation Panel – Diecutter. Symbol 20,21,41-50
 - C. Operation Panel – Stripper. Symbol 55-59
 - D. Operation Panel – Delivery back stopper and front edge stripper. Symbol 61-65
 - E. Operation Panel – Delivery. Symbol 71-86, 91, 92
 - F. Operation Panel – Manual Drive. Symbol 39, 40
 - G. Indicator Lights – Self-diagnostic Display Panel. Symbol 1-8, lamps 9-19.

2. Main Drive
 - 2.1 Description
 - 2.2 Speed control
 - 2.3 Start up of motor and machine
 - 2.4 General Synchronization
 - 2.5 Start-up
 - 2.6 Manual drive

3. Sheet traveling check
 - 3.1 Functions of the photocells

4. Physical protections
 - 4.1 Various safety devices
 - 4.2 How to get into machine
 - 4.3 Emergency stop

5. Feeder
 - 5.1 Operation
 - 5.2 Setting the feeder
 - 5.3 Warp board

6. Diecutter
 - 6.1 General description

- 6.2 Control of cutting force
- 6.3 Platen locked under pressure
- 6.4 Description of die-cutting equipment and materials
- 6.5 Fitting of die into chase
- 6.6 Handling of die-cutting equipment
- 6.7 Make ready
- 6.8 Creasing counterparts

7. Stripper

- 7.1 Description
- 7.2 Rise and descent of stripping frame
- 7.3 Fitting of female stripping board
- 7.4 Working without stripping

8. Delivery

- 8.1 Description
- 8.2 Front stripping
- 8.3 Pre-selection counter

9. Make-ready and start-up

10. LCD Display

11. Maintenance and Lubrication

SPECIFICATION & TECHNICAL DATA

Possible stock:

Solid board	Min. 1.5mm
Corrugated board	F.E.C.B.A.AB and other flute up to 9mm
Sheet size	Max. 1620x1200mm (63 ⁵ / ₇ "x42 ¹ / ₅ "") Min. 650x450mm (25 ² / ₅ "x17 ² / ₃ "")
Cutting size	Max. 1600x1180mm (63"x46 ² / ₅ "")
Inner chase size	1630x1215mm (64 ¹ / ₆ "x47 ³ / ₅ "")
Cutting plate size	1650x1186mm (66 ⁴ / ₅ "x5065 ³⁰ / ₃₁ " x46 ¹¹ / ₁₆ "")
Gripper edge waste (Distance from first knife to sheet front edge)	Min. 12mm
Gripper bite margin	Min. ±3mm
Cutting pressure	Max. 400 tons
Main motor power	22KW
Total power connected load	30KW
Voltage	380V, 3PH, 50/60HZ
Net weight	32 tons
Machine dimension	9980x5670x2480mm (LxWxH)

ETERNA

INSTRUCTIONS

PE1620SA-Extra

Chapter 1

GENERAL OPERATION CONTROLS

1. GENERAL OPERATION CONTROLS

A. FEEDER 25-35



25

Selector switch of blower

To switch on: put selector switch on 1.

To switch off: put selector switch on 0.



26

2-position selector switch of feeding roll

To switch on: put selector switch on 1.

To switch off: put selector switch on 0.



27

Push button for continuous operation.

When power is on, press this button and hold for 3 seconds then release, the machine will start.



28

Two-step push button for jogging

Depress and release this push button, siren will be signaling. within 3 seconds after siren signaling stop, depress this push button again. Keep pressing for jogging, release to stop jogging.



29

Mushroom machine stop push button.

To declutch and stop machine without stopping main motor.



30

Three-position selector switch for rear jogger.

Pos.0: inoperative.

Pos.1: one stroke per sheet.

Pos.3: one stroke every three sheets.

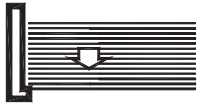

31

Push button for adjusting the front guide position down.



32

Push button for adjusting the front guide position up.



33

3-position selector switch of side gauge adjustment
Left: Operation surface control
Center: Simultaneous control of operation and drive
Right: Drive surface control



34

Side gauge increase button



35

Side gauge decrease button



50

Stop button
The same as 50



51

Three-position selector switch for side jogger (OOS):
Pos.0: inoperative.
Pos.1: one stroke per sheet.

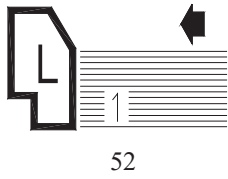

Three-position selector switch for side jogger (OS):

Pos.0: inoperative.

Pos.1: one stroke per sheet.

Pos.3: one stroke every three sheets.

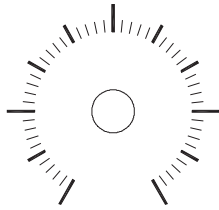

Potentiometer for setting vacuum volume of blower of feeder:

Turning dial clockwise: Increase.

Turning dial counterclockwise: decrease.

A: FEEDER

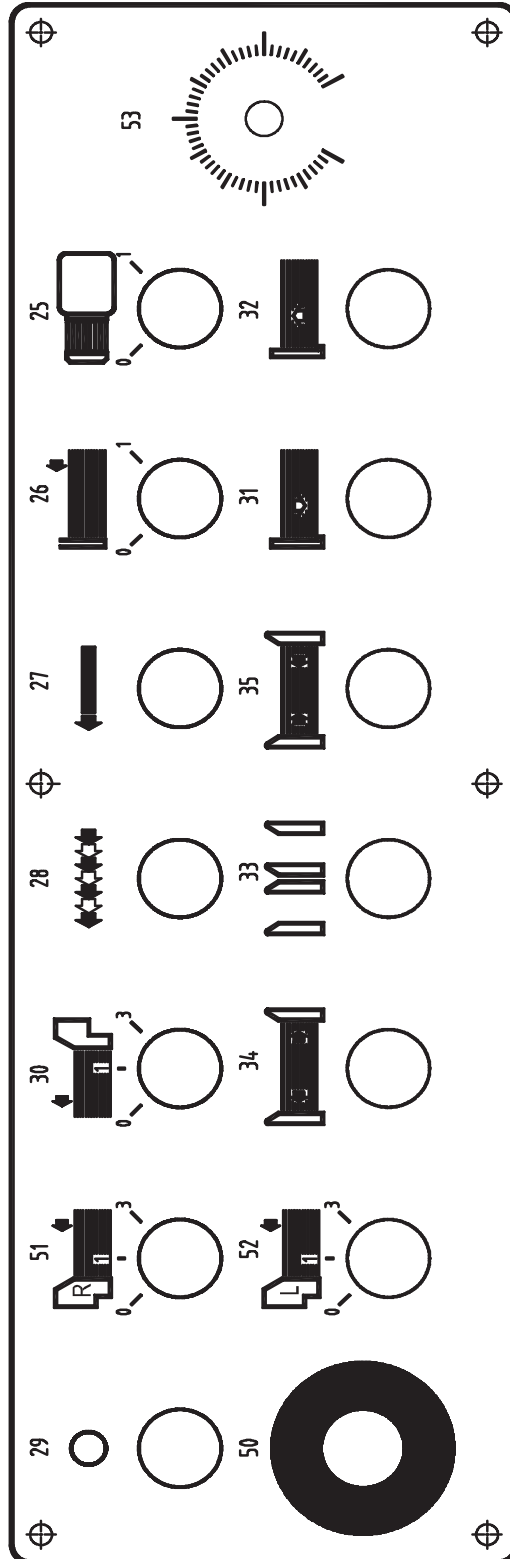

B. DIE CUTTER 20,21,41-50

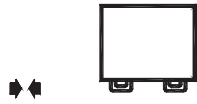

20

Push button for die chase locking,
Depress once to lock the chase.
If the chase is locked, depress once to unlock the chase.



21



Push button for moving the lower platen down to “die chase out” position.
Depress this push button, the lower platen will move down to the lowest position and stop.



41

Main power key switch.
Pos.0: to cut off the main power of the machine completely.
Pos.1: to turn on the main power of the machine after the switch on the main power box turned on. The key switch in this position will enable machine control circuits and motor to be ready for function.



42

Push button for controlling main motor.
Depress the push button to stop the main motor.

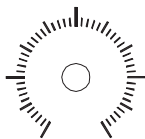

43

Potentiometer for setting running speed.
Turning dial clockwise to increase speed.
Turning dial counterclockwise to decrease speed after the Potentiometer is actuated by push button 46.



44

Two step push button for start up of control circuits and continuous run.
Identical to 27



45

Mushroom machine stop push button.
Identical to 29



46

Luminous push button for speed acceleration and deceleration.

To increase the speed, setting the potentiometer 43 at the position which represents the speed desired, press the button, light in the button shall be on, the speed will accelerate progressively up to the rate set on the potentiometer. Depress the push button again to decrease the speed down to crawling speed



47

Two step push button for jogging.

Identical to 28



48

Selector switch for photocell system inspection.

Pos.0: photocell off.

Pos.1: photocell on.



49

Push button for controlling main motor.

Depress the push button to start up the main motor.



50

Emergency mushroom stop button.

Depress this push button to stop the die cutter even with platen in upper position. Main motor will slow down to minimum speed and stop.

B: DIE CUTTER

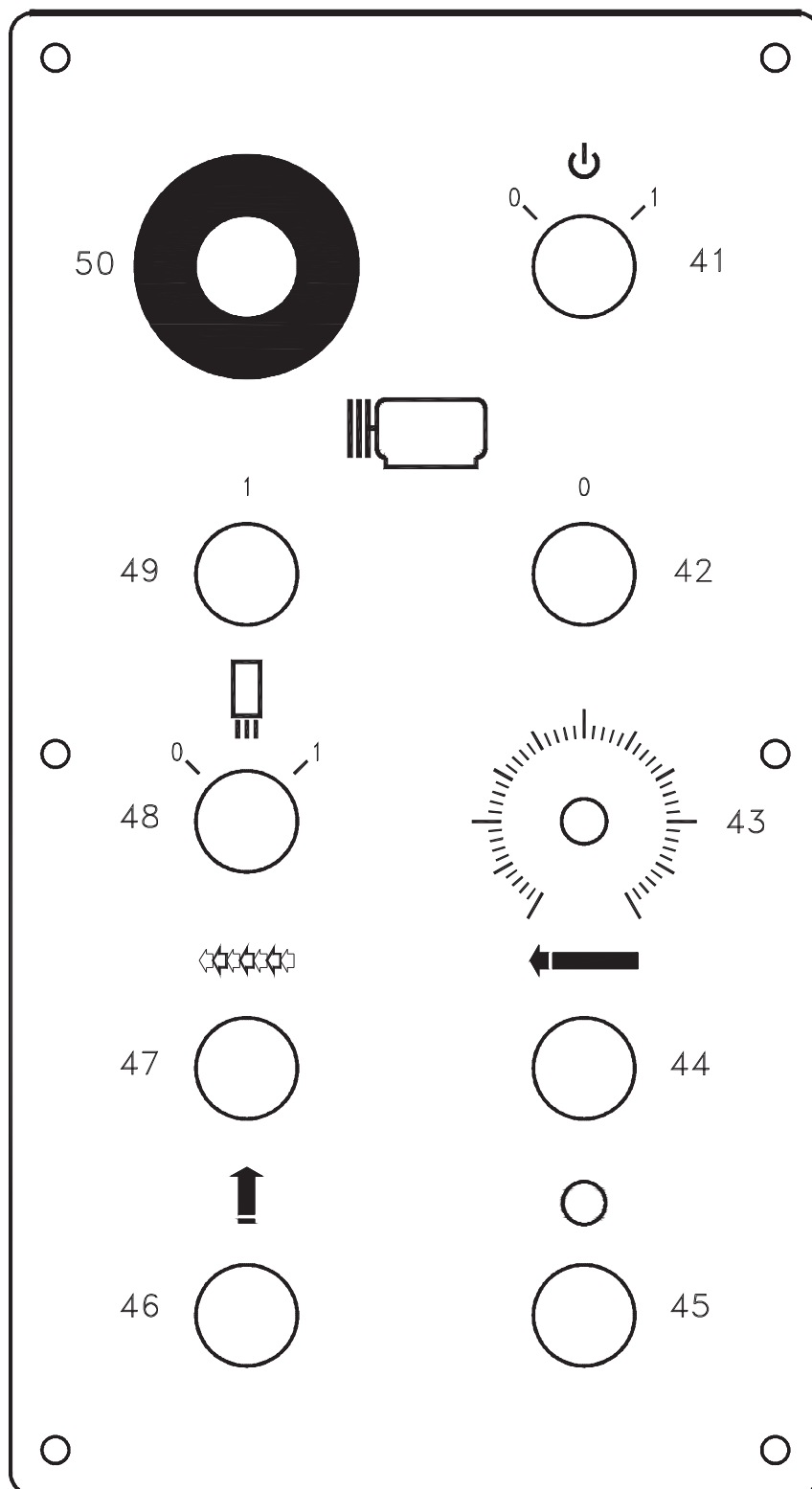

C. STRIPPING 55-59

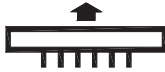

55

Luminous push button for moving upper chase up.

Depress this push button and keep pressing, upper chase will continuously move up.

Release the push button to stop. The light in the button will light up if the chase hits the up limit position and chase will stop moving.



56

Luminous push button for moving upper chase down.

Depress this push button and keep pressing, upper chase will continuously move down. Release the push button to stop. The light in the button will light up if the chase hits the down limit position and chase will stop moving.



57

Two-step push button for jogging

Identical to 28



58

Two-step push button for start up of control circuits and continuous run.

Identical to 27



59

Mushroom machine stop push button.

Identical to 29

C: STRIPPING

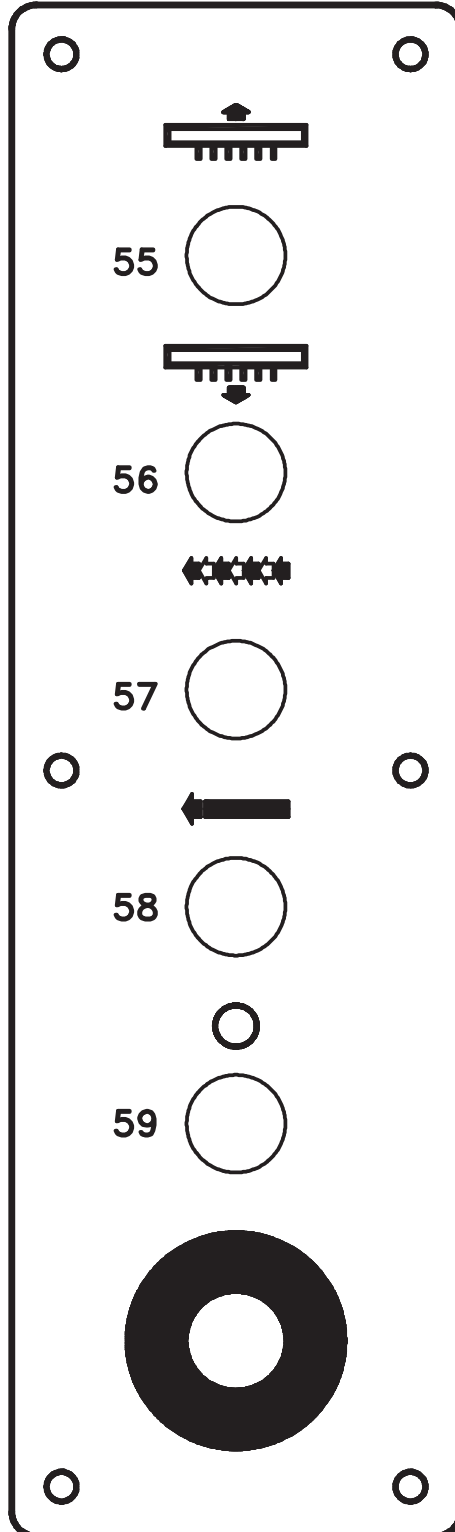

D. DELIVERY BACK STOPPER AND FRONT EDGE STRIPPER 61-65



61

Luminous swivel selector switch for moving the delivery back stopper forward and backward

Turn to left and hold it to move the back stopper forward continuously. Release the switch to stop. Turn to right and hold it to move the back stopper backward. The light in the switch will be on if the back stopper hits ultimate position at each end.



62

Selector switch for sheet pusher.

Broken line: sheet pusher inoperative.

Real line: sheet pusher operative



63

Selector switch for gripper opening at front waste removal.

Left: close

Right :open(open gripper and release front waste,lamp will light up)



64

Two-position luminous selector switch to lock and unlock the upper front edge waste stripping tool.

Left: unlock (light in the push button will light up to indicate the tool is not locked).

Right: lock (to clamp the upper front edge waste stripping tool in the carrier).



65

Two-position luminous selector switch to lock and unlock the lower front edge waste stripping tool.

Left: unlock (light in the push button will light up to indicate the tool is not locked).

Right: lock (to clamp the tool in the holder).

D: DELIVERY BACK STOPPER AND FRONT STRIPPER

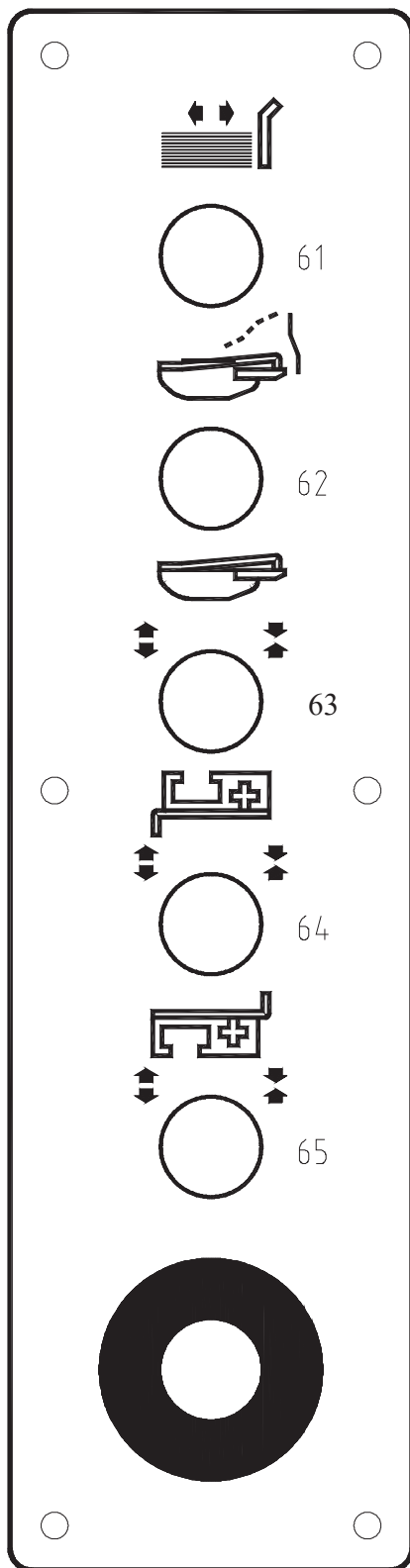

E. DELIVERY



71

Two-position selector switch for turning on and off the counter.

Pos.0: off.

Pos.1: on.

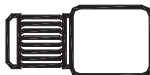

72

Push button to stop the blower of feeder.

Depress this push button to stop the blower of feeder.

73

Preselect batch counter determining number of sheets to be batched in delivery.

Depress knob underneath each digit dial to allow pre-selection of number of sheets to be batched.



74

Three-position selector switch of counter/ejector control

Auxiliary cylinder will come out when pre-set quantity of sheets batched in full to catch the sheets of next batch. In between, there can be sheet interval.

Pos.1: No sheet interval at pre-set bundle quantity.

Pos.2: One sheet interval at pre-set bundle quantity number.

Pos.3: Three sheets interval at pre-set bundle quantity.



75

Two-position selector switch to turn on and off the front edge waste remove conveyor

Pos.0: off.

Pos.1: on.



76

Luminous push button to withdraw the auxiliary cylinder.

Depress this push button to withdraw the auxiliary cylinder. The light in the button will light up to indicate the status.



77

Two-step push button for start up control circuits and continuous run.

Identical to 27.



78

Mushroom machine stop push button.

Identical to 29.



79

Luminous push button for speed acceleration and deceleration.

Identical to 46.



80

Two-step push button for jogging.

Identical to 28.



81

Luminous push button to push out the auxiliary cylinder.

Depress this push button to push out the auxiliary cylinder. The light in the button will light up to indicate the status.

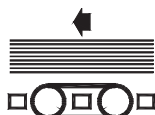

82

Two position selector switch of delivery conveyer.

Pos.1: Automatic sheet pile moving out to delivery table (when machine is running).

Pos.2: Manual sheet pile moving out to delivery table (when machine is inoperative)

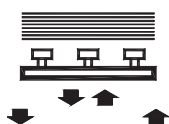

83

Two position selector switch for control delivery main pallet up and down.

Left : going down.

Right: going up.

84

Timer for setting delivery main pallet descending stroke distance.

Turning the dial to set the desired time allowing main pallet descending.

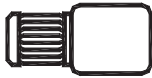

85

Push button to start up the blower of feeder.

Depress this push button to start up the blower of feeder.

86

Sheet counter zero resetting knob at bottom of unit.



87

Emergency stop button.

Depress this push button to stop the die cutter even with platen in upper position. Main motor will slow down to minimum speed and stop.

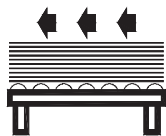

91

Tow position selector switch of delivery auxiliary pallet.

Identical to 82.



92

Mushroom machine stop push button identical to 29.

F. MANUAL DRIVE



39

Two-position selector switch for manual drive

Pos.0: following machine operation status. (manual drive is not allowed.)

Pos.1: ready for manual drive. Insert and push in the ratchet wrench to actuate the clutch on, now the machine is ready for manual drive.



40

Mushroom machine stop push button.

Identical to 29.

E1: DELIVERY

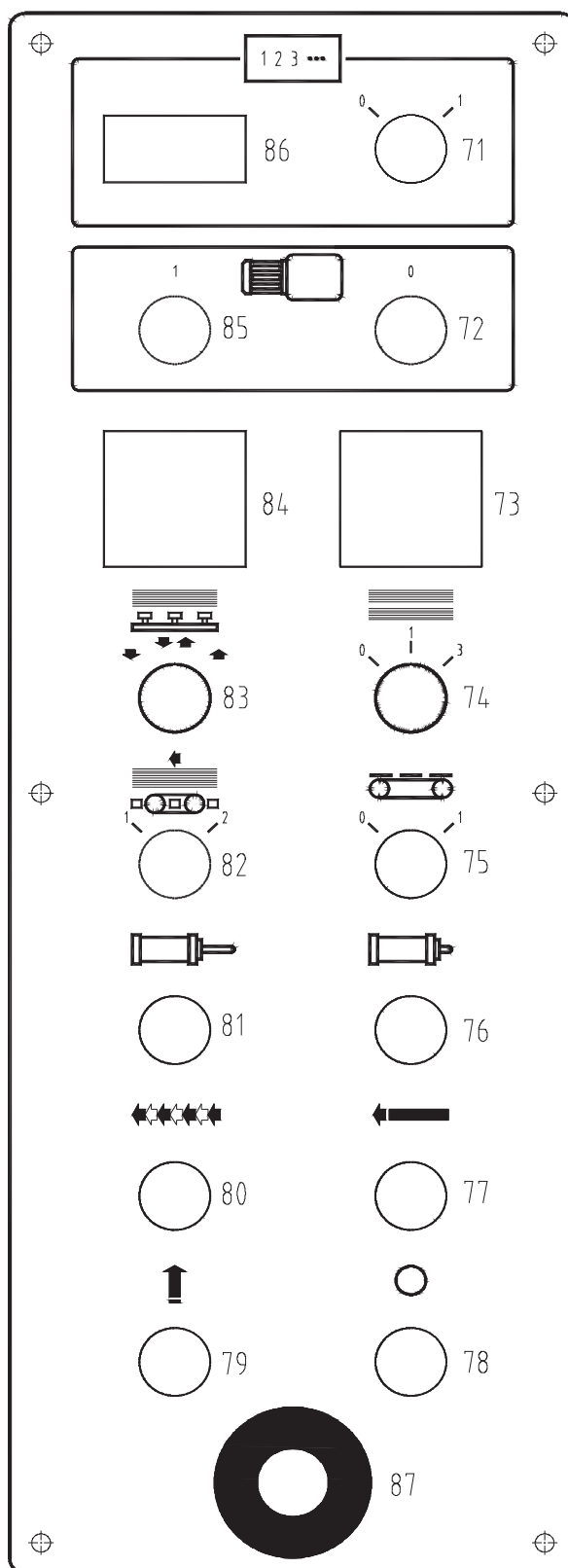

E2: DELIVERY

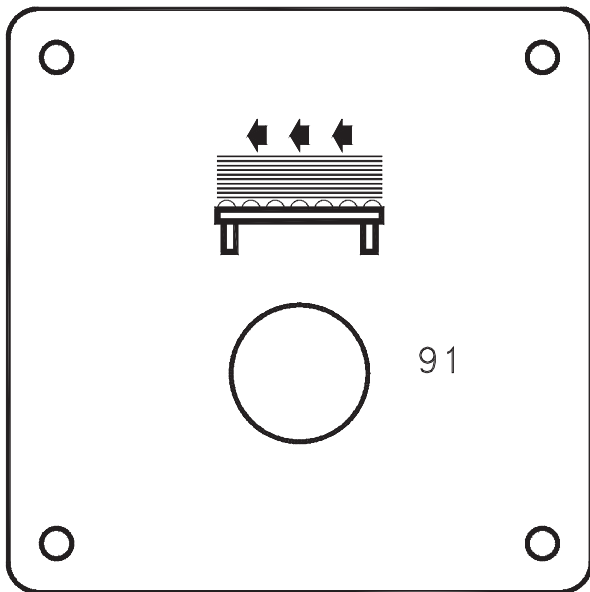

F: MANUAL DRIVE

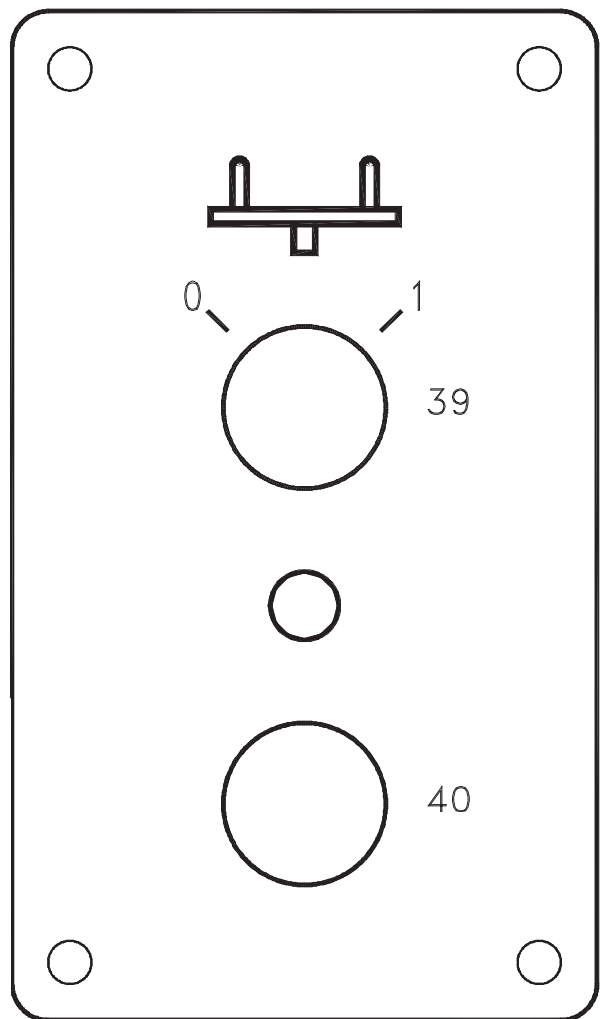

E3: DELIVERY

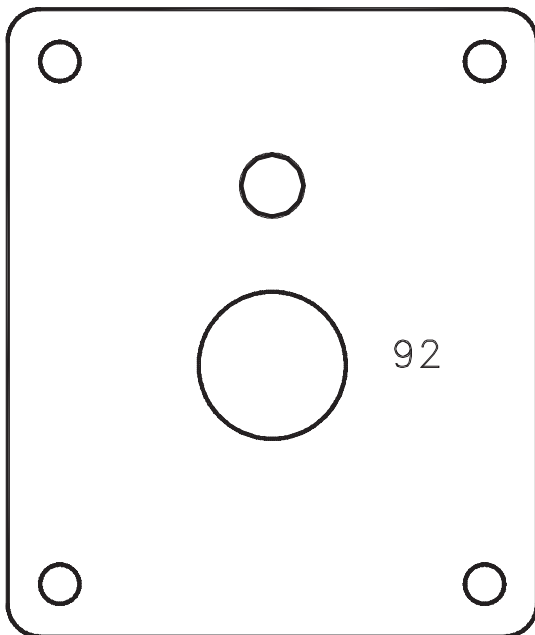

G. INDICATOR LIGHTS ON SELF-DIAGNOSTIC DISPLAY PANEL



1

Indicator light, signaling main power supply on



2

Indicator light, signaling DC power supply on.



3

Indicator light, signaling PLC run.



4

Indicator light, signaling insufficient air pressure from compressor or factory main air source, pneumatic clutch/brake not operative.



5

Indicator light, signaling torque limit coupling declutched.



6

Indicator light, signaling emergency stop actuated.



7

Indicator light, signaling ordinary stop switched on.



8

Indicator light, signaling one of the safety guards not closed.

- 9 Indicator light, signaling delivery trouble, sheet not released at delivery.
- 10 Indicator light, signaling sheet pile at delivery goes over the height limit, machine stop, siren actuated.
- 11 Indicator lamp – difficulties with the sheet transfer at the output end of the stripping station.
- 12 Indicator lamp – difficulties with the sheet transfer at the output end of the diecutting station.
- 13 Indicator light, signaling die chase not locked.
- 14 Indicator light, signaling die cutting plate is not pushed to the end position.
- 15 Indicator light, signaling oil pressure in main cycling circuit too low or oil pump thermo relay trapped off.
- 16 Indicator light, signaling sheet front edge misaligned at front lay.
- 17 Indicator light, signaling double sheet detector triggered.
- 18 Indicator light, signaling sheet early arrival at infeed.
- 19 Indicator light, signaling main motor over loaded.

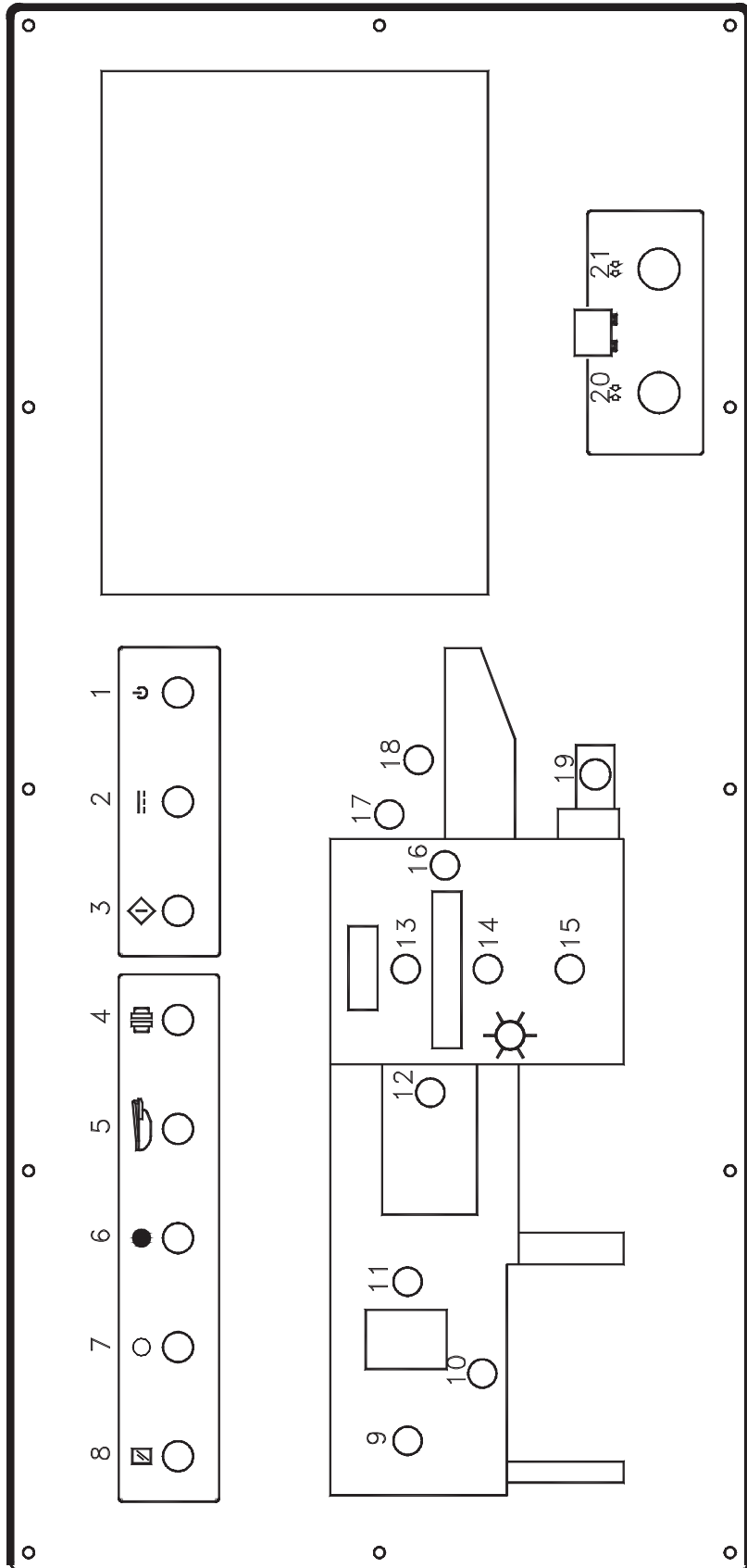

G: INDICATOR LIGHT

B-C STRIPPER OUTLET PHOTOCELL



95

Stripper outlet photocell three position selector switch

Pos.1: Operation side sheet out detect sensor

Pos.2: Drive side sheet out detect sensor

Middle position: Sheet out detect sensor for both o.s. and o.o.s.



96

Diecutting outlet photocell three position selector switch

Pos.1: Operation side sheet out detect sensor

Pos.2: Drive side sheet out detect sensor

Middle position: Sheet out detect sensor for both o.s. and o.o.s.

C2 MACHINE STOP KEY SWITCH (At o.o.s. of stripping section)



Pos.0: Key switch is activated, machine stops.

Pos.1: Key switch is not activated, machine runs normally.

B-C: DIECUTTING & STRIPPING OUTLET PHOTOCELL

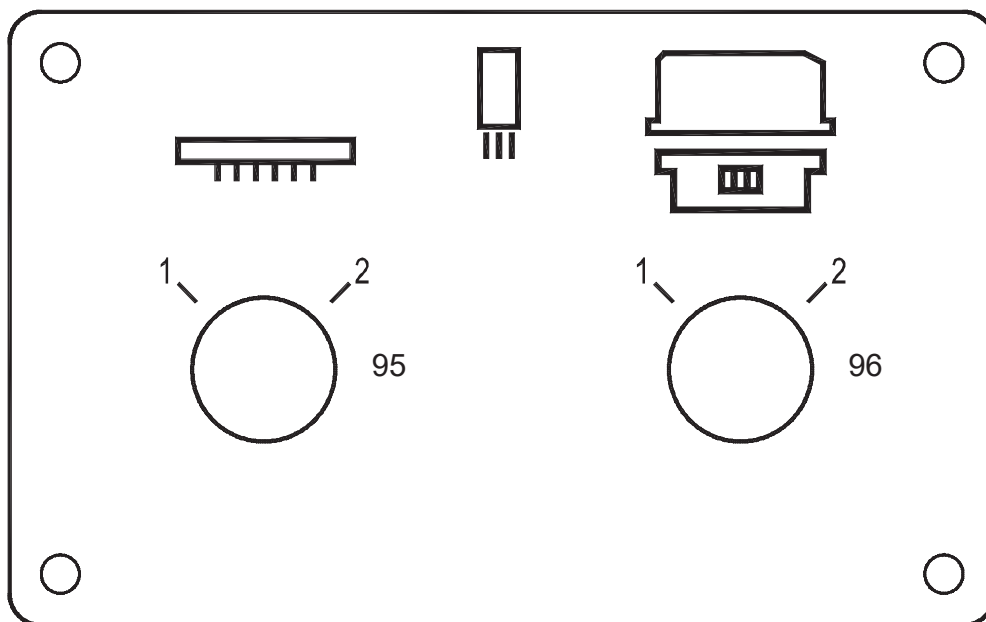

C2: MACHINE STOP KEY SWITCH

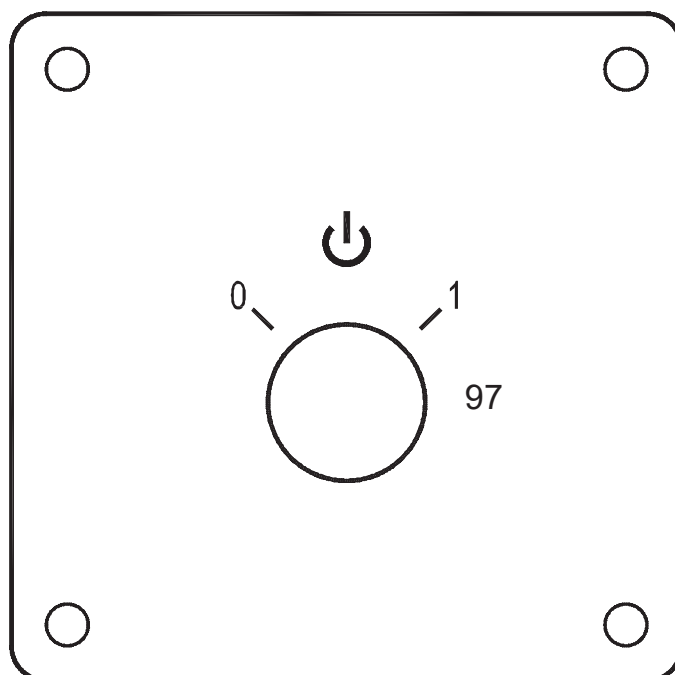

ETERNA

INSTRUCTIONS

E1620SA-Extra

Chapter 2

MAIN DRIVE

2. MAIN DRIVE

2.1 DESCRIPTION

The machine is driven by a 3-phase AC motor with inverter speed control.

The motor drives the worm through a flywheel and a pneumatic clutch/brake. The clutch operates when either the jog button (28) or the continuous run button (27) is depressed. The worm moves the lower beam of the platen through a mechanism consisting of wheel crank and toggles.

2.2 SPEED CONTROL

The speed of the main motor of the machine is set through an inverter, controlled by a potentiometer.

Potentiometer at zero = minimum speed of machine, that is 1200 cycles/hour.

Potentiometer at 10 = maximum speed of machine, that is 4500 cycles/hour.

To increase the speed, set the potentiometer at the position which represents the speed desired, press push button (46), light in the button shall be on, then with progressive acceleration up to the rate set on the potentiometers, to press the push button again to decrease the speed down to crawling speed.

2.3 START-UP OF MOTOR AND MACHINE

After switching-on the main motor, a 10-second timer prevents the clutching-in of the machine as long as the motor and flywheel has not reached their full speed. The first push on the jog or continuous run button merely operates a hooter. When the hooter stops, the button is to be actuated again in order to start up the machine.

2.4 GENERAL SYNCHRONIZATION

The general synchronization and also the sheet transfer check operated by sensors, controlled by PLC through an encoder linked to the main drive, the general synchronization at sheet transfer timing can be adjusted through program LCD in PLC through LCD screen.

2.5 START-UP

1. Switch on the main switch.
2. Turn select switch (41) to switch on control circuits.
3. Start the main motor through push button (42).
4. Turn select switch (48) to actuate sensor detect circuit.
5. Start the pressure-vacuum pump through switch (25).
6. Depress push-button (47) for jog or (44) for continuous run.

2.6 MANUAL DRIVE

Manual drive is necessary in the following cases:

1. To release the platen from its upper locked position, if jogging is not sufficient (see 6.3).
2. To restore torque limit coupling device.

Proceed as follows:

1. Stop the main motor. Do not depress an emergency stop, because the brake release push-button would be inoperative.
2. Insert and push in the ratchet wrench at the end of the shaft (fig. 2.3). Turn the safety switch (39) to 1 position. Then clutch will be on. And operate the ratchet wrench. (see fig. 2.1)

Right: Reverse run.

Left: Forward run.

3. Turn selector switch(39) to position 0.Remove ratchet spanner, pull lever down and pull out gearwheel to separate the shaft and manual drive.

Pull the lever down to declutch the shaft end to the main drive.

4. To restore torque limit coupling device.

When gripper bar's movement is forced to slow down or to stop by any obstacle and the counter force produced is over the torque limit set, the torque limit Coupling Device will be disconnected to prevent the index and related main drive system from damage by the shock. Should it be happened, the indicator light 5 shall be on and signaling the declutch of the torque limit coupling device and the timing of the gripper bar with the main machine is out. In this case the torque limit coupling device needs to be restored per following procedures:

- a. Open the transparent safety door at in feed.
- b. Fit the recouping wrench on to the flange of the chain sprocket wheel with the extension bar.
- c. Turn the recouping wrench downward till the device is restored at the recouping position. At this moment a click noise shall be heard. (see fig. 2.1)
- d. Depress push button 49(P1-7) and check the indicator lights to see if it is turned off. If yes, the torque limit device is restored, If push button 49 doesn't work and indicator light is on, need to repeat the above steps(1-3).
- e. Take the recouping wrench off and close the door.
- f. Manually drive the machine per steps mentioned in 1,2,3 to check if the timing between gripper bar and machine is correct. If yes, machine is in ready to run condition again.

TORQUE LIMIT CLUTCH

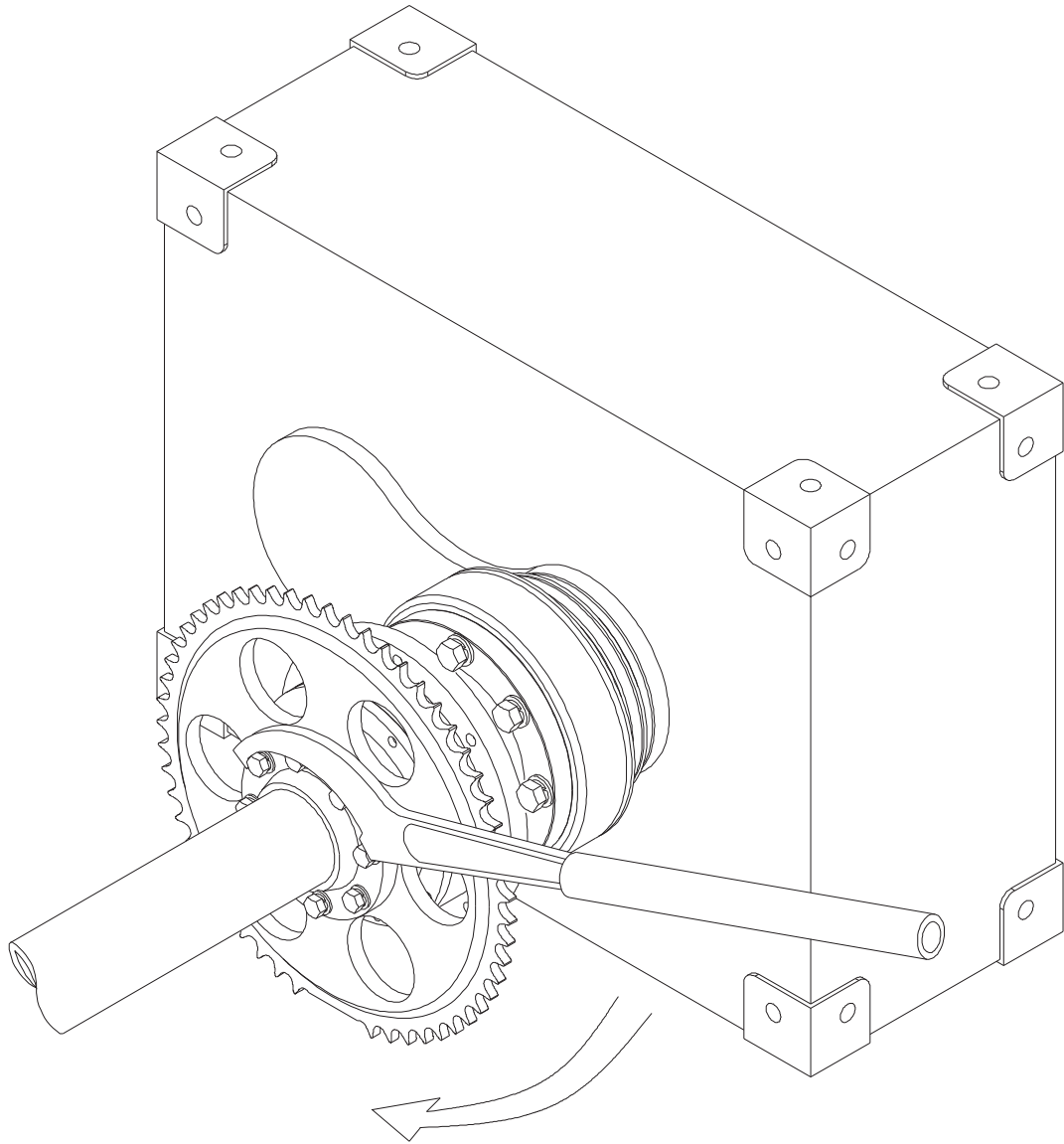

Fig. 2.1

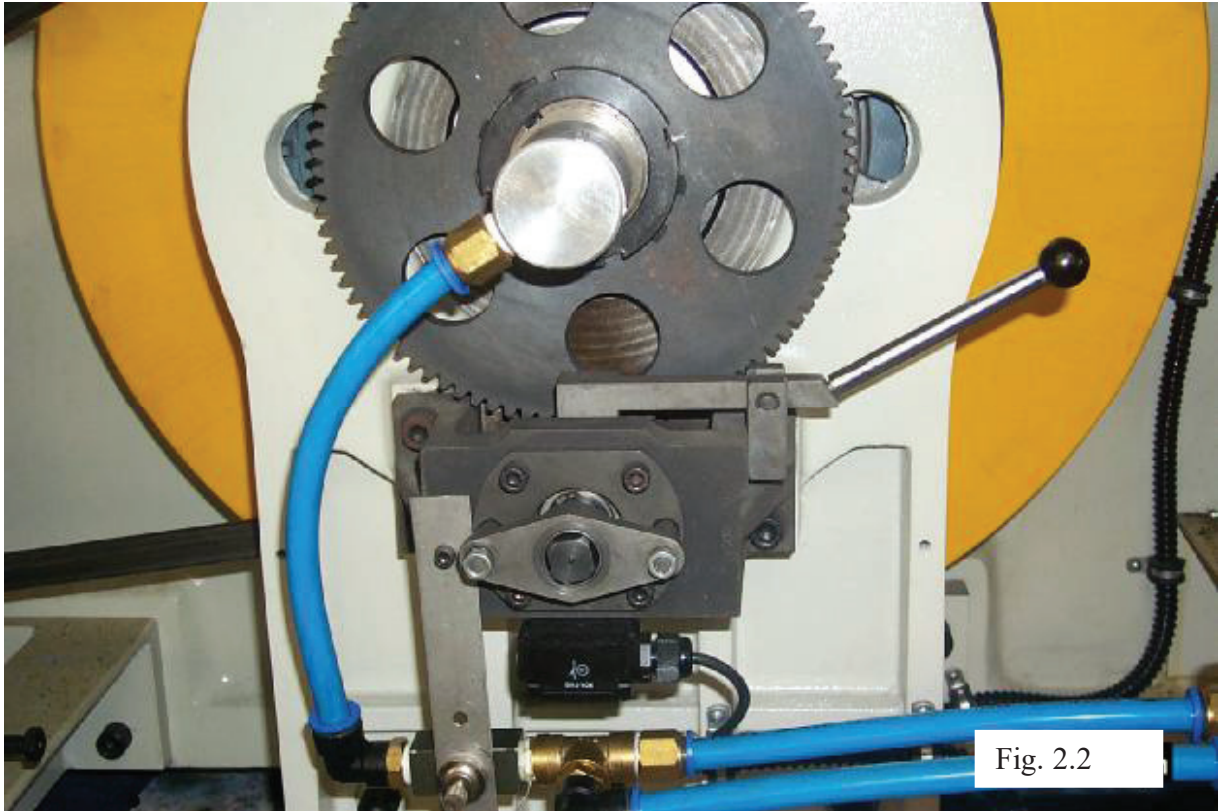

Fig. 2.2

Reduced gear and safety system for manual drive



Fig. 2.3

Insert and push in the ratchet wrench at the end of the shaft.

ETERNA

INSTRUCTIONS

PE1620SA-Extra

Chapter 3

SHEET TRAVELING CHECK

3. SHEET TRAVELING CHECK

3.1 FUNCTIONS OF THE PHOTOCELLS (fig. 3.1)

3.1.1 Infeed Photocell (18)

The photocell is at the top, facing down.

Purpose:

To check if sheet arrives early. At machine degree 200° — 205° , infeed photocell PH2 check to the sheet arrival, if sheet arrives, light 18 will be on, machine stops.

3.1.2 Front Lay Photocell (16)

Two fiber photocells at the bottom.

Purposes

- 1) To check the sheet arrival timing at front lay.
- 2) Just after the gripper bar starts moving, it checks whether the sheet has been carried away. If no sheet is detected, but the Infeed photocell(18) did detect the sheet, machine will stop.

3.1.3 Platen Outlet Photocell (12)

The photocell is at the top facing down.

Purposes

- 1) If photocell (16) has detected a sheet during the previous cycle, photocell (12) checks whether it has appeared at the platen outlet. The sheet is checked on a position from the front edge, at a previously chosen point, which is determined by the adjustable disk of program in PLC. The photocell detects whether a sheet has appeared completely from the diecutting section, from a position at the diecutting support table. If no sheet is detected, it shows the sheet has dropped in the diecutting section, then lamp 12 shall light up and the machine stop.
- 2) To check whether the space between the end of the sheet and the following gripper bar is free, which means that the sheet has not been dropped inside the stripper. In the event of a fault, lamp lights up and the machine stops.

3.1.4 Stripper Outlet Photocell (11)

The photocell is at the top, facing down.

Adjust the side position of the photocells to make sure it is located on the right spot.

Purposes

Identical to the platen outlet cell. Furthermore, these photocells provide the counting pulses needed for the batch separation. In the event of a fault, lamp (11) light up and the machine stops.

3.1.5 Delivery Center Photocell

The three reflection photocell is mounted opposite to its reflector.

Purpose

- 1) Check whether the paper drops normally into the delivery section.
- 2) Wrong setting of the counter may cause the excessively high paper piling.

In the event of a fault, lamp (10) lights up and the machine stops.

3.1.6 Delivery pile height photocell (10)

The reflection cell mounted opposite to their reflection.

Purpose

- 1) Check if there is any obstruction before the cylinder reaches out.
- 2) Check the rise and stop of the main lifting platform and the withdrawing of the cylinder.

3.1.7 Delivery counter/ejector auxiliary cylinder photocell (10A)

The reflection cell is mounted opposite to a reflector.

Purpose

To check if it is clear before the cylinders come out. In case of a fault, lamp (10A) lights up and the machine stops. Furthermore, it checks the main pallet coming up arrival, stop the main pallet, then cylinders withdraw.

3.1.8 Delivery output cell (9)

The reflection cell is mounted opposite to a reflection.

Purpose

To check if the paper pile is ejected and pushed out to the delivery table, then stop the roller in turning and allow the main pallet to go up.

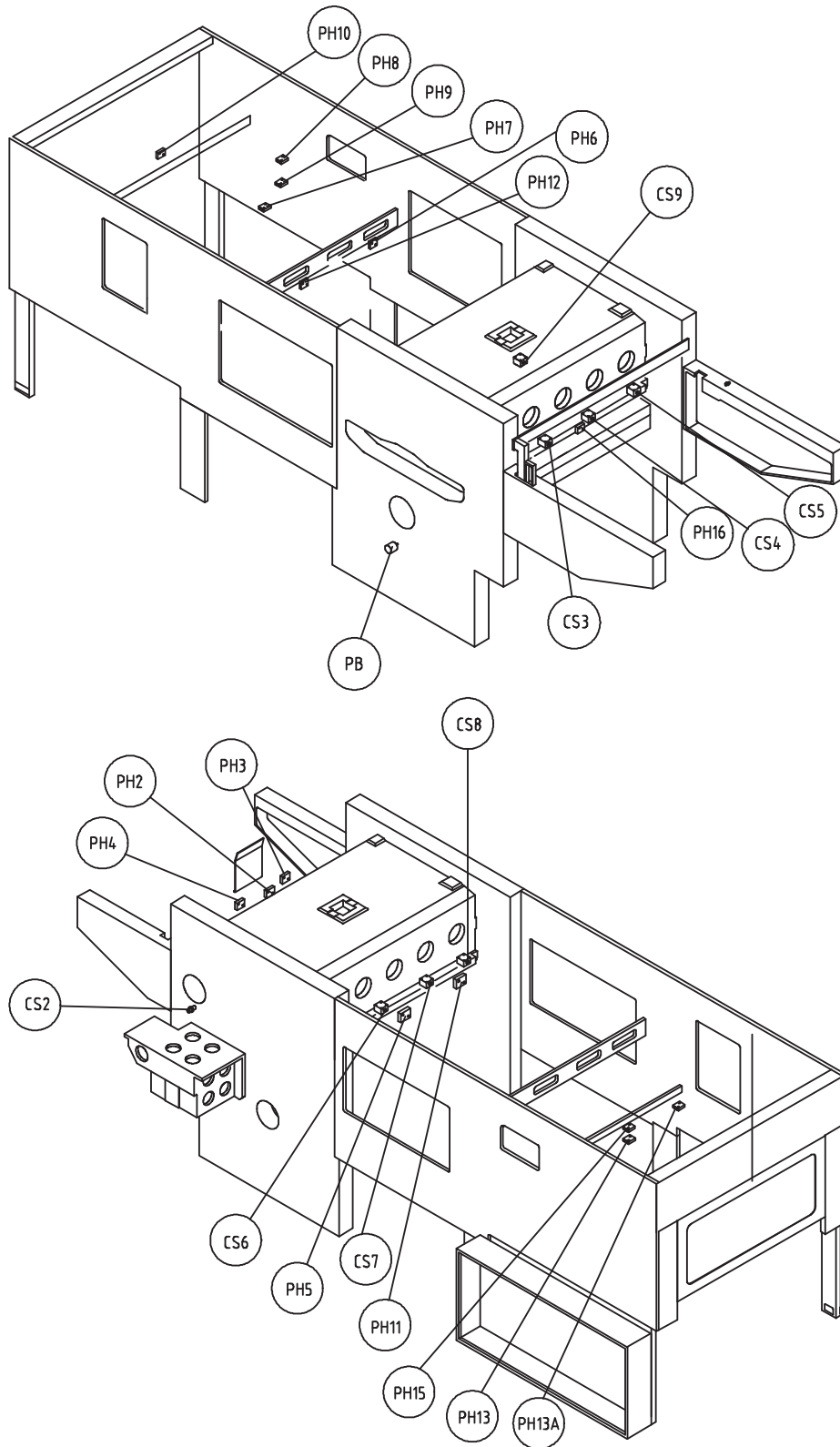

PHOTOCELL LOCATION DIAGRAM

Fig. 3.1

ETERNA

INSTRUCTIONS

PE1620SA-Extra

Chapter 4

PHYSICAL PROTECTIONS

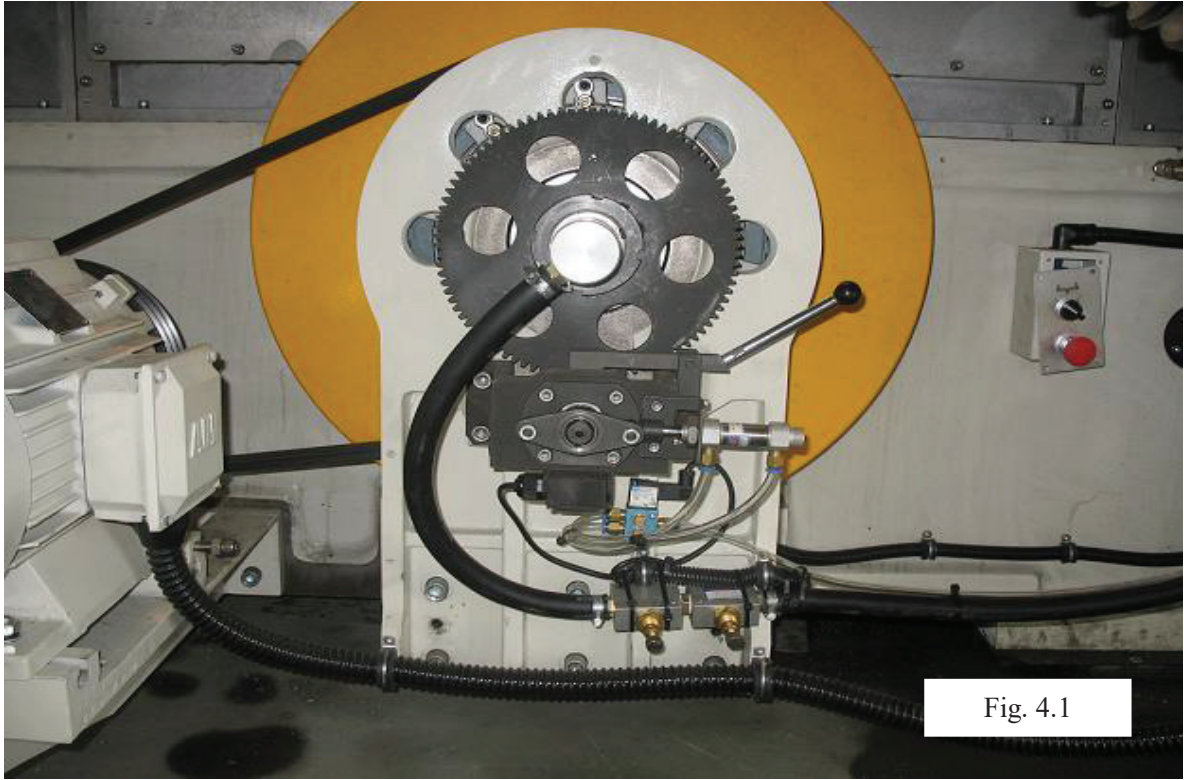

Fig. 4.1

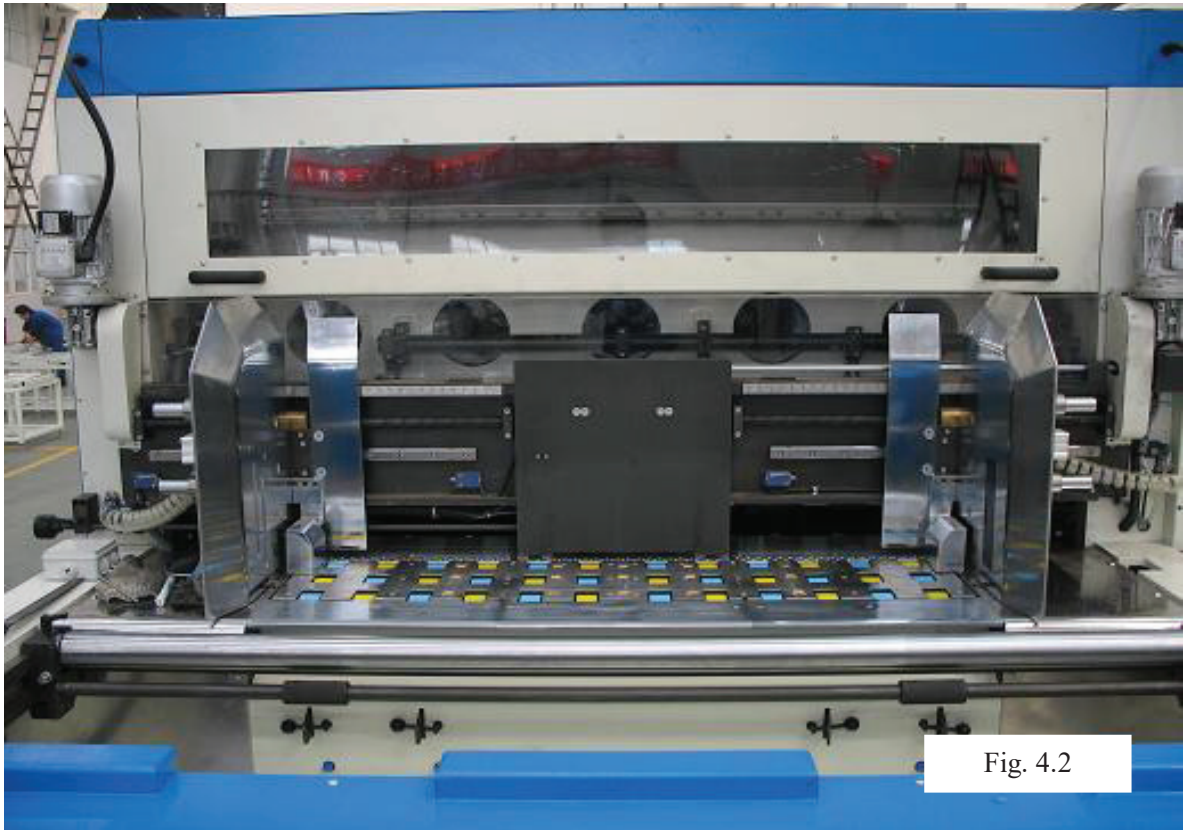

Fig. 4.2





Fig. 4.5

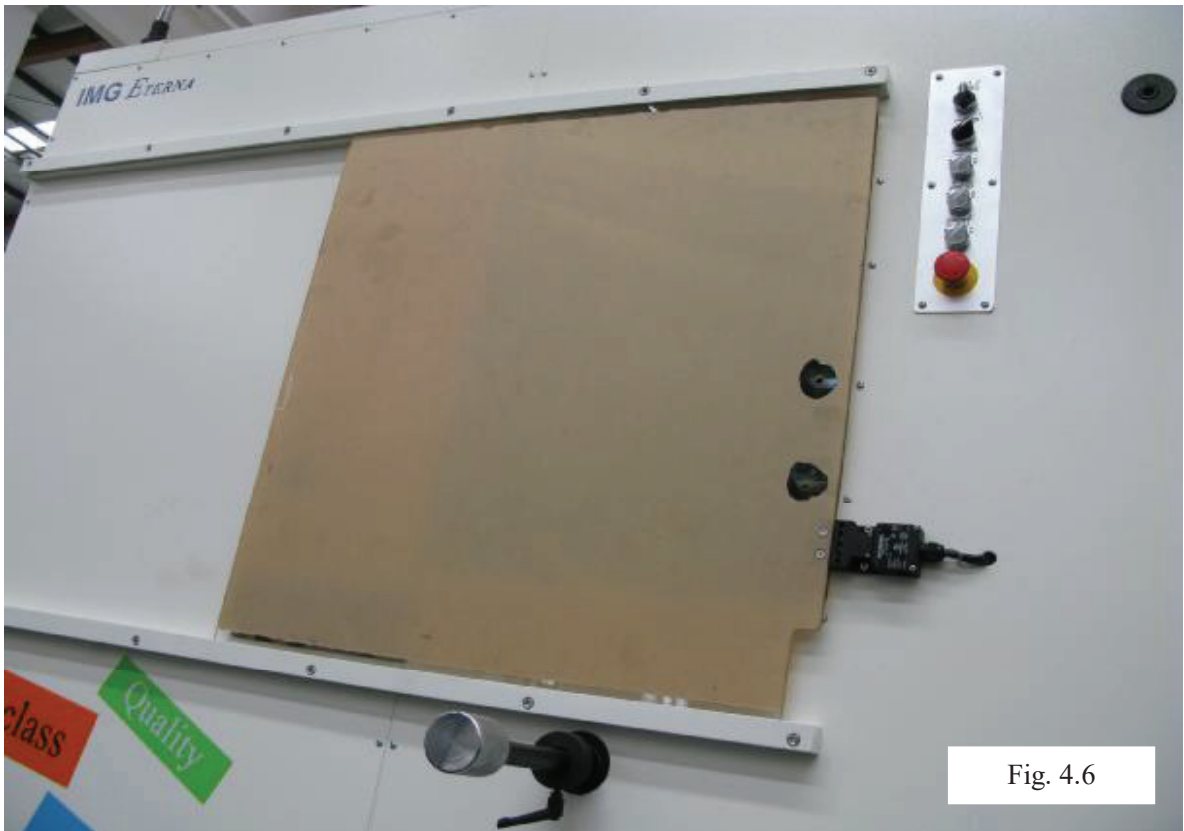

Fig. 4.6



Fig. 4.7



Fig. 4.8

4 PHYSICAL PROTECTIONS

4.1 VARIOUS SAFETY DEVICES

The machine has personnel safety switches at the following locations:

Feeder

- Reduction gears for manual drive.(fig. 4.1)
- Opening door protecting the sprocket wheels at platen inlet(fig. 4.2)

Platen

- Transparent guard.(fig. 4.3)

Stripper

- Transparent opening door, operator's side.(fig. 4.4)
- Drive side safety door.(upper and lower)(fig. 4.5)

Delivery

- Transparent window, operator's side.(fig. 4.6)
- Transparent opening door, delivery end.(fig. 4.7)

If one of these safety guards is not closed, the indicator light (8) lights up and the machine can not be started.

If machine is running when one of these safety devices is opened, machine stops.

Important: It is extremely dangerous to make a safety switch inoperative for easier access to the machine or for any other reason. In such events, we decline any responsibility.

4.2 HOW TO GET INTO MACHINE

For any servicing into the machine, the key (41) must be withdrawn. We decline any responsibility in the event of an accident due to non-observation of this rule.

4.3 EMERGENCY STOP

In order to restart the machine after use of the emergency stop:

1. Reset the emergency stop push button 50.
2. Start the main motor (push button 49).
3. Actuate the sensor detect circuit (selector switch 48).
4. Depress push-button 44 to start up the machine.

5. Start the blower (selector switch 25).

The machine is fitted with one device designed to prevent a mechanical failure in case of jam or of overpressure.

It is torque limit coupling device protecting index unit.(to restore the torque limit device see 2.6 manual drive).

ETERNA

INSTRUCTIONS
PE1620SA-Extra

Chapter 5

FEEDER



Fig. 1

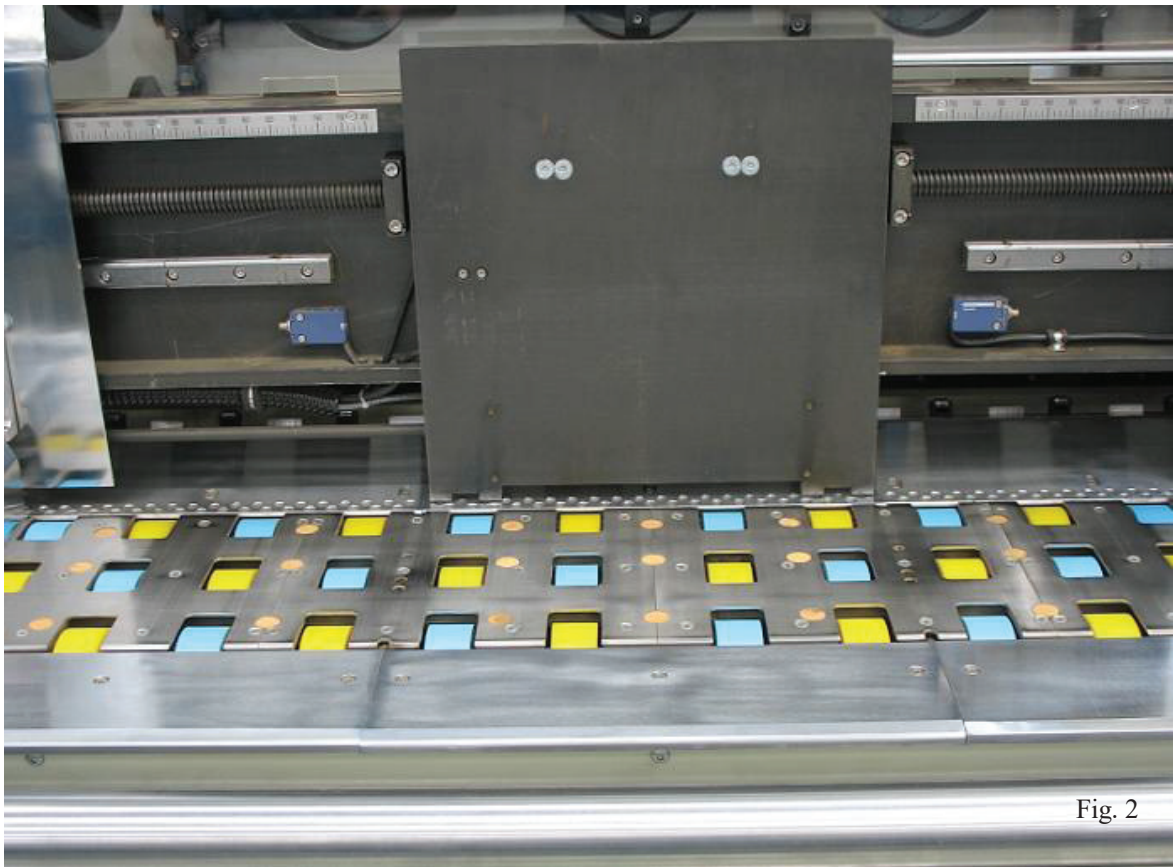

Fig. 2

5.1 Note

5.1.1 LOWERING GRATE (Figure 1)

Description

The lowering grate is a “cross hatch” assembly which is positioned to span the vacuum box. The grate bars are coated to reduce friction between it and the corrugated board.

Function

The grate will rise and fall on each revolution of the machine (dependent on the position of the feed interrupt and skip feed switches - see electrical control section).

Its purpose is to allow each consecutive sheet in the hopper to come into contact with the feed wheels for a given time during the feed cycle. When the grate is in the low position the board will feed forward. When the grate is in the upper position no board will feed.

Precautions

1. The grate is levelled to within 5 thousandths of an inch or 0.125 of a millimeter in both directions. Any undue pressure or weight must be avoided, such as standing on the grate bars, as any deviation on the level will cause feeding problems.
2. Do not attempt to remove any waste paper which may be trapped in the grate whilst the machine is in operation.

5.1.2 FEED WHEELS (Figure 2)

Description

The feed wheels are comprised of two parts:-

- a) Wheel core (aluminium)
- b) Wheel tread (polyurethane)

The number of wheels depends upon the size of the machine into which the feeder is fitted.

Function

The feed wheels rotate in both forward and reverse directions. On the forward stroke, a sheet will be fed to the front lay of the gripper bar (dependent on the position of the feed interrupt and the skip feed switches - see electrical controls section).

Precautions

1. Do not attempt to remove any waste paper or any other item which may be trapped in the feed wheel assembly whilst the machine is in operation.
2. Should any item become permanently in contact with the polyurethane tread whilst the machine is in operation, then this should be removed as soon as possible. If allowed to remain in contact it will cause a premature and unnatural wear pattern on the tread. Refer to paragraph 1 above.

5.1.3 FRONT GUIDE/SIDE GUIDE (Figure 1)

The front guide/side guide shall be installed in the standard manner.

Precautions

- The feed gates should be set to allow one sheet of board to pass but not two.
- As a general rule, the front guide should be set to give 1mm clearance above the board.
- This should prevent two sheets from passing through at the same time.

5.1.4 BACKSTOP (Figures 3)

Description

The backstop is an assembly which is set to be parallel to the feed rolls. It is adjustable to cater for different sizes of board in the feed direction.

Function

The backstop is used to keep the board in the hopper firmly against the front guide. If the individual sheets became uncontrolled in the hopper and therefore allowed to become “out of square” to the feed rolls then this will result in an “out of square” box. It is important to keep the board firm, but not too tight against the front guide to prevent the “out of squareness” from happening.

The backstop can be positioned very close to the vacuum box or to a maximum distance away depending on the length of the board the machine is capable of handling. Any position in between max. and min. sheet can be reached at using the hand wheels - see Figure 1.

To use the hand wheels first slacken off the locking device, turn the wheel until the desired position is reached, then lock again once the positioning has been completed.

This locking device prevents inadvertent movement during machine operation. One hand wheel controls the backstop upward and upward in the feed direction and the other hand wheel controls the backstop forward and reverse in movement.

Precautions

1. Always ensure that the board is square in the hopper and use the backstop to keep it square to the front guide.
2. Always use the locking devices on the hand wheels.
3. Ensure the area is clear before moving the backstop in any direction.



Fig. 3

5.1.5 VACUUM SYSTEM (Figure 4)

Description

The vacuum system is comprised of two main parts

- a) The vacuum chamber
- b) The vacuum fan

The vacuum chamber is basically the wheel box. It is divided into sections, the number of which depends on the size of the wheel box. Each section can be shut off by the use of slide gates. These are positioned at the base of the wheel box. Only the middle section cannot be shut off and is permanently open to suction.

The vacuum fan creates the suction required to hold each sheet firmly against the lowering grate. It is controlled by operating an electrical switch (see controls section). The amount of suction is controlled through changing the frequency of the converter.

Function

To pull the corrugated paper evenly to the lowering grate, the suction system shall be

provided with sufficient suction, which is very useful to the bent paper.

The vacuum slide gates control suction to sections of the wheel box, therefore the suction can be concentrated to the size of board being run. The slide gates should either be fully in or fully out.

Precautions

1) Caution should be used when the machine is in operation and the vacuum fan is on.

The suction is extremely strong and is capable of pulling any loose articles into the vacuum chamber. Tools and other items may damage the impeller.

2) Ensure that the duct and dust collection system are clean, as any blockage will cause a deterioration in efficiency.

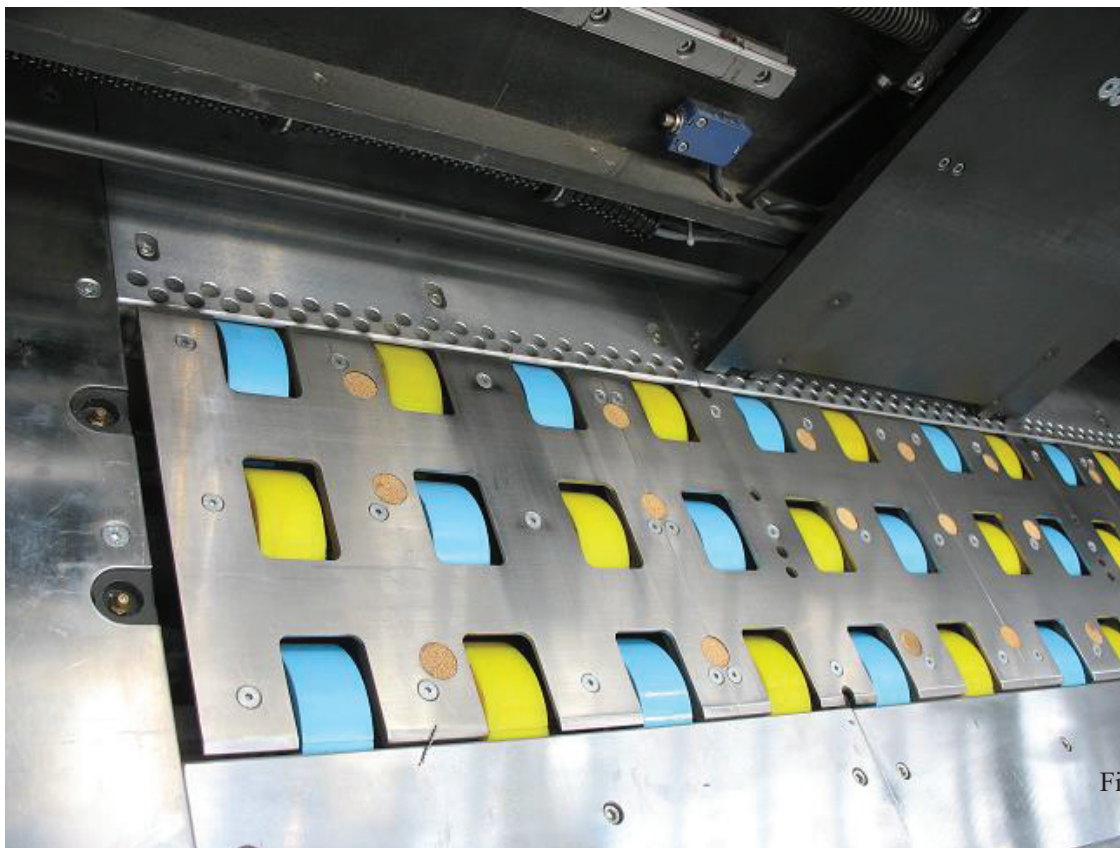

Fig. 4

5.1.6 ELECTRICAL CONTROLS Figure 1

Description

There are a small amount of electrical controls associated with the Primtec Accu-Feed.

They are:-

- b) Feed interrupt
- c) Skip Feed

They are all identified on the switch control station.

5.1.7 BLOWER MOTOR (VACUUM FAN) SWITCH (2 position)

This switch will start the blower motor when it is in the **1** position and will stop the blower when it is in the **0** position.

5.1.8 FEED INTERRUPT SWITCH (Push/Pull)

Set Switch 26 to position 1 to start paper delivery; and pull switch to position 0 to stop delivery.

Setting UP Procedure

- 1) Obtain a sample of board to be run.
- 2) Using the machine datum set the feed gates for both position and height for the appropriate size of sheet to be run.
- 3) Using the machine datum set the side guides for the approximate size of sheet to be run.
- 4) Using a sheet of board to be run, place it in the feeder against the feed gates and set the backstop to keep the sheet firm, but not tight against the feed gates.
- 5) Set the vacuum slide gate to the appropriate width of the sheet to be run.
- 6) When ready to run, switch on the blower motor and allow approximately 30 seconds for suction to be stabilized.
- 7) When ready to feed board through the machine, switch Feed Interrupt ON to allow the sheets to be fed into the nip of the feed roll.
- 8) A Belly Bar can be used when running long and heavy board which tends to sag in the unsupported region between backstop and vacuum chamber - see figure 1.

5.2 SAFETY AND OPERATING GUIDELINES

Feed Interrupt

1. Always stop the feed cycle (feed interrupt) before stopping the machine. This prevents undue wear on the lowering grate mechanism and stops the grate movement when there is no board present.
2. Try to stop the feed cycle (feed interrupt) as soon as possible after the last sheet has been fed, then slow the machine down to a stop.

Pile Height

1. The board pile height in the feeder should be set at a reasonable level, dependent on board quality. Generally, the level should be kept at the following height:-

2. Try to place the board in the hopper and not to “slap” each handful down on the top. This can cause a bad feed at the time of impact.
3. Do not stand or place any heavy objects on the feeder grate. This may distort the grate bars and give poor feeding.

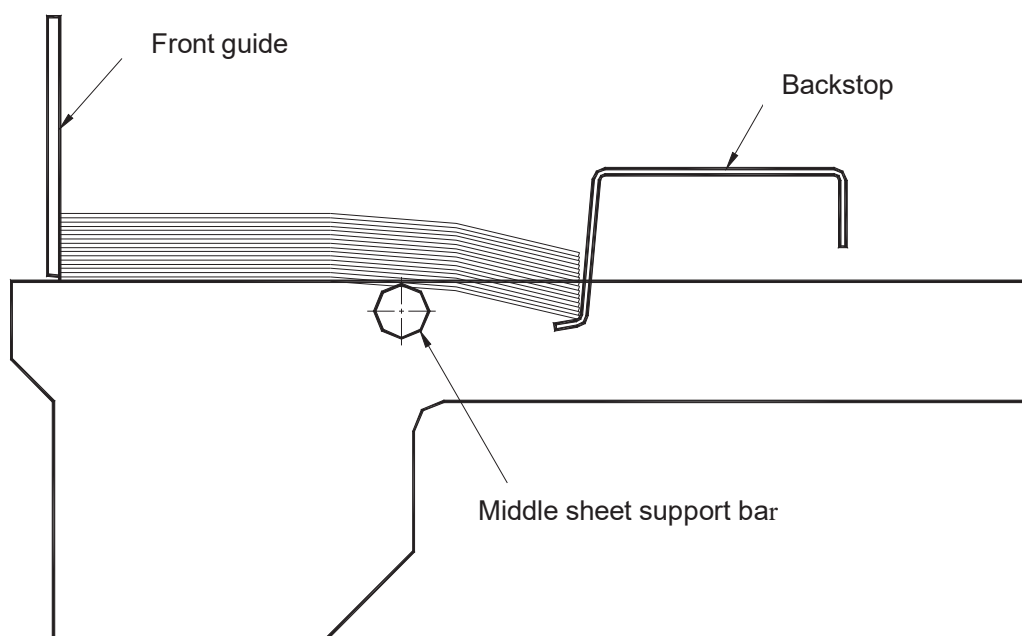
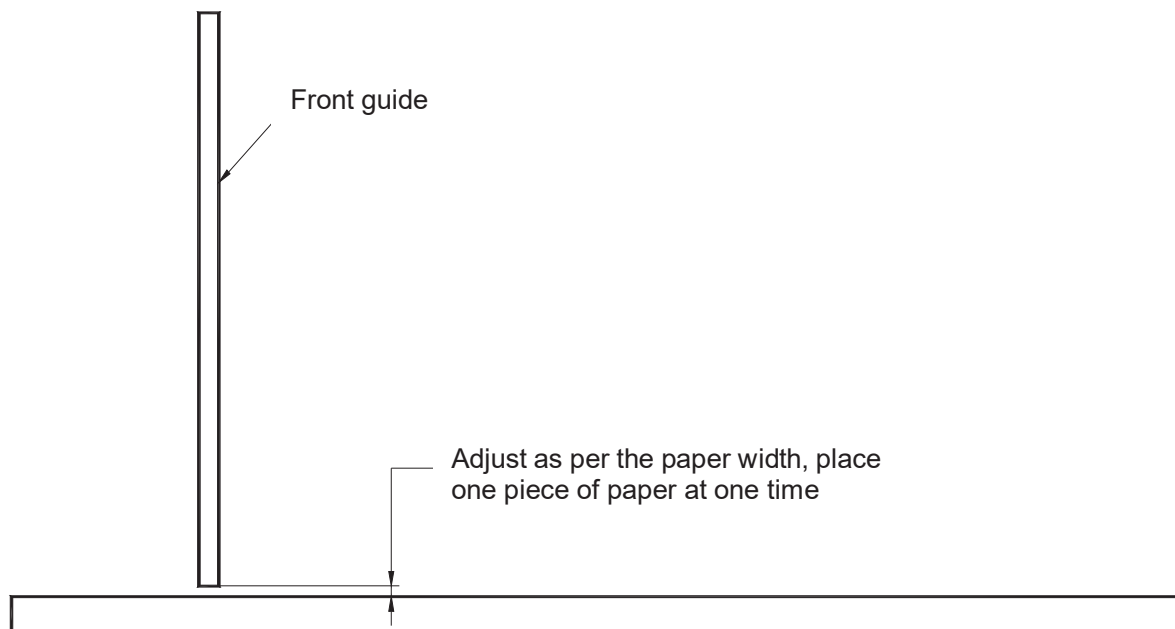

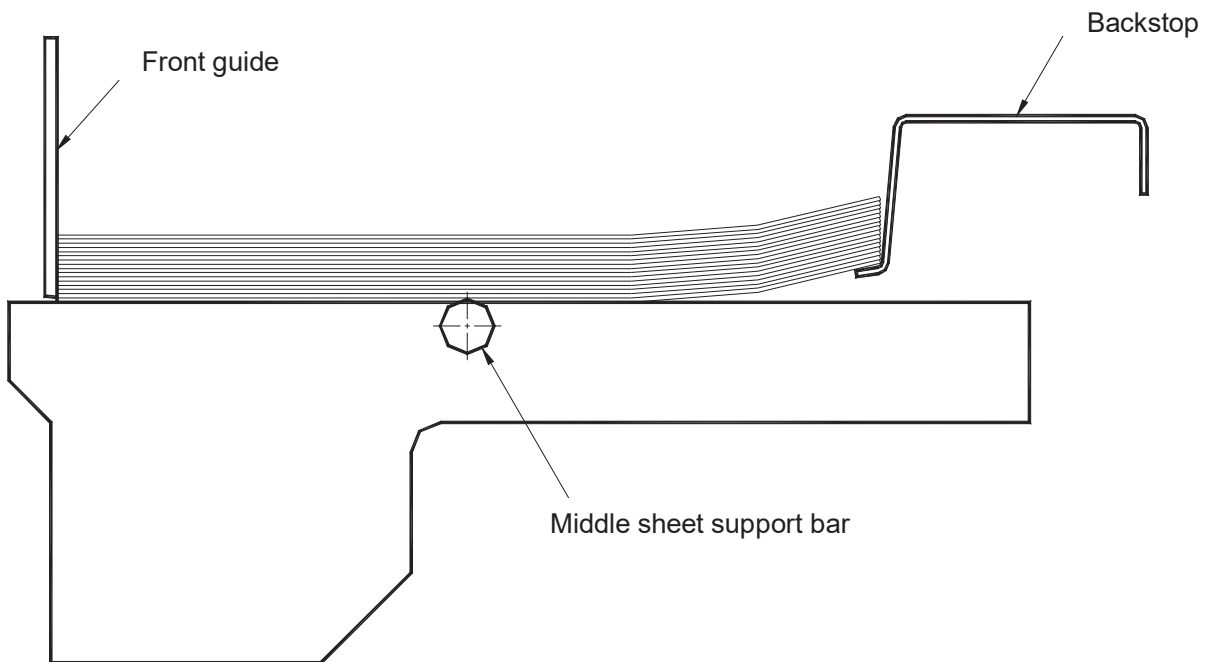
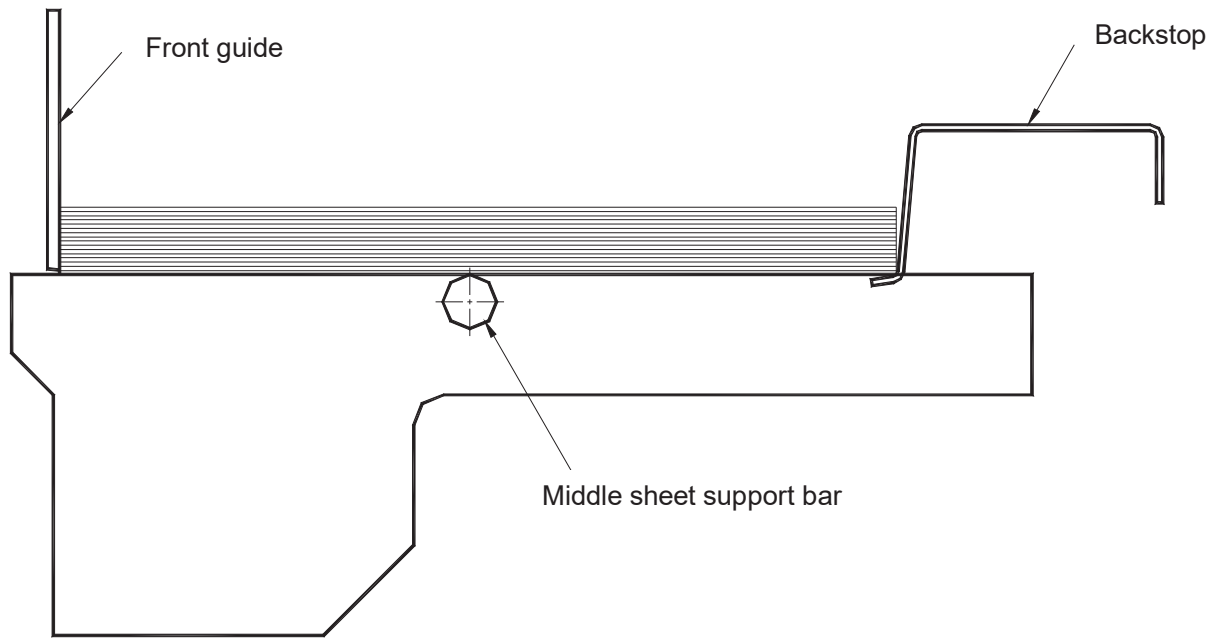

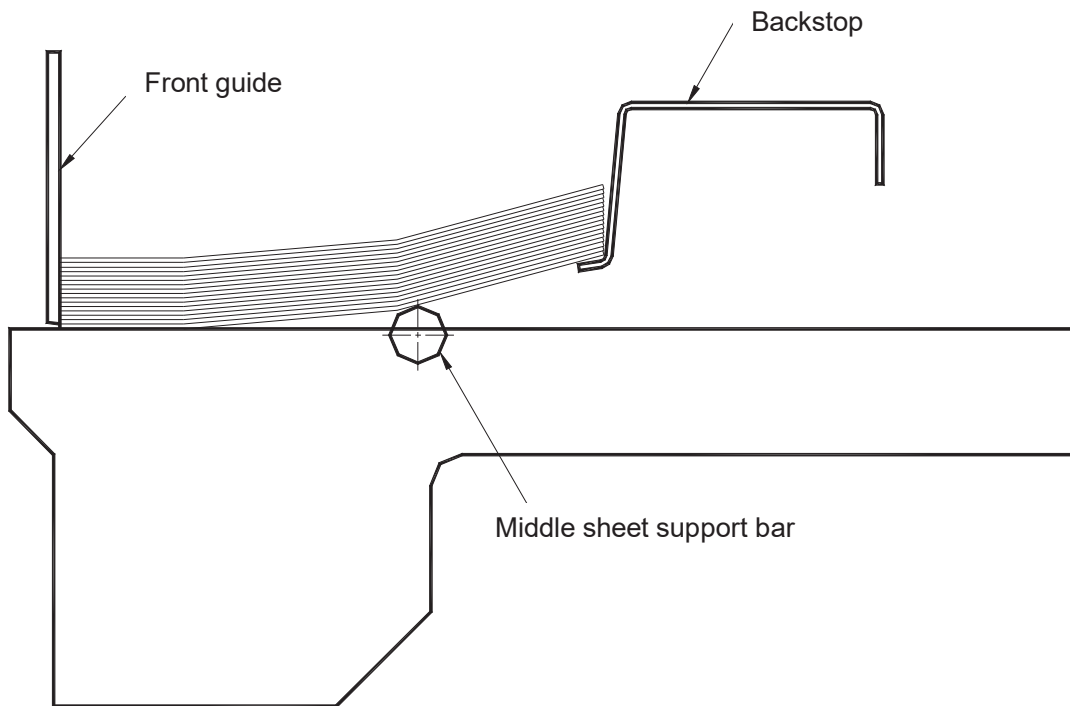
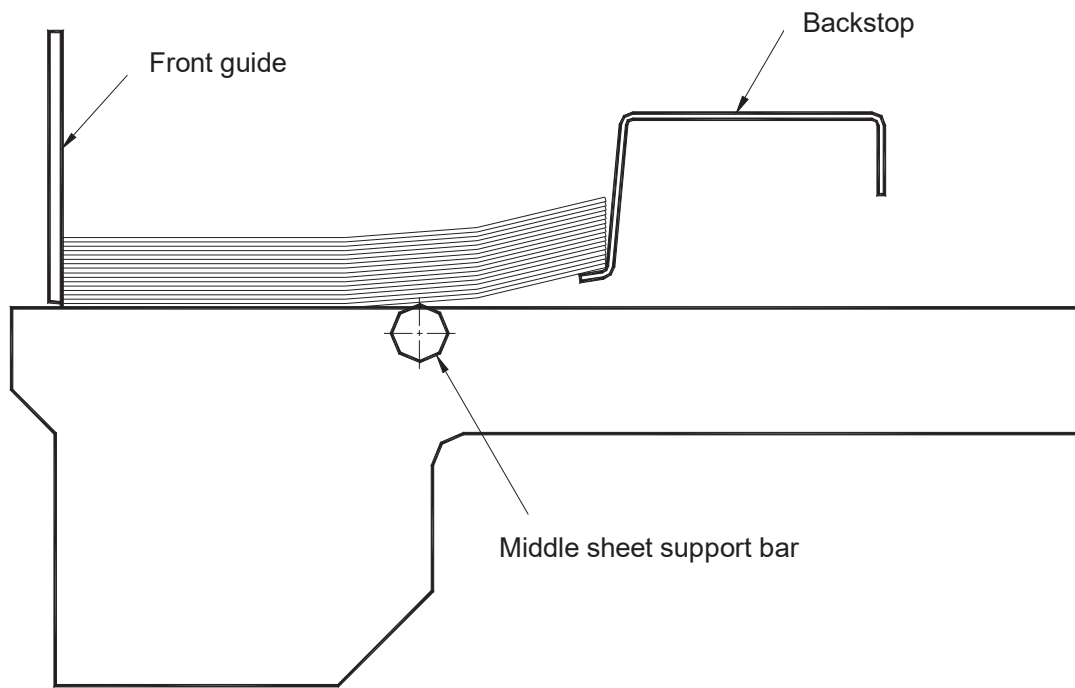

5.3 Maintenance

5.3.1 Cleaning

- 1) Blow off the dust on the feeder at each shift.
- 2) Blow off the dust on the suction chamber at the end of each shift.

Once every week

- 1) Lubricate the shaft bracket (one drop).
- 2) Lubricate all the remaining lubricating points requiring lubrication.

Once every month (remove the protection devices on both sides)

- 1) Rotate the delivery wheel.
- 2) Check the worn areas of the cam side.
- 3) Check the backstop.
 - a) Remove all the protection devices and lubricate all the backstop gears.
 - b) Check whether the backstop device operates correctly.

Once every year

- 1) Check the wheel to avoid excessive wear.
- 2) Remove and clean the vacuum closing slide gate and the impellor.
- 3) Replace the oil in the gear box.
- 4) Check the electric wire.
- 5) Check the lowering grate to ensure it is
 - a) Stable and
 - b) safe.

5.3.2 Recommendation for Lubrication

<u>Description</u>	<u>Lubrication</u>	<u>Interval</u>
Transmission case	Shell gear lubricant 634	Discharge waste oil, flush and replace with new oil
Bearing	NLGI Grade 2	Once a week
Cam box	NLGI Grade 2	Once a week
Sealed control bearing	NLGI Grade 2	Once a week
Input shaft	NLGI Grade 2 (in sleeve)	Packaging sleeve with lubricant
Universal joint	Light oil in central pin	
Air hose	No. 10	Keep full

TROUBLE SHOOTING TIPS

Symptoms	Possible Causes	Remedies
MISFEEDING (SHEET ADVANCES QUARELY, BUT NOT HOLDING REGISTER)	Vacuum blower not running	Turn on blower switch
	Vacuum blower rotation (insufficient vacuum)	See blower housing for correct rotation
	Backstop adjustment	Refer to set-up guide
	Pile height too high	Reduce pile height to reduce weight
	Feed roll pressure	Set to calibre of board
	Grate level	Refer to grate leveling procedure
	Worn or damaged drive	Check cam drive and components dog bone connections for excessive lash
SKEWING (SHEET ADVANCES BUT PRINT & DIE CUT NOT PERPENDICULAR)	Vacuum blower not running	Turn on blower switch
	Vacuum blower rotation (insufficient vacuum)	See blower housing for correct rotation
	Wrong paper delivering distance	Adjust position of eccentric shaft PA2014, to make paper stop when just reaching front lay
	Vacuum not distributed	Refer to set-up guide evenly
	Feed gates not aligned	Re-shim feed gates to be even with each other
SKIP FEED/FEED INTERRUPT NOT FUNCTIONING	No incoming air supply	Check incoming line for leaks. etc
	Air pressure not set properly	Set regulator to 50-60 psi

ETERNA

INSTRUCTIONS
PE1620SA-Extra

Chapter 6

DIECUTTER

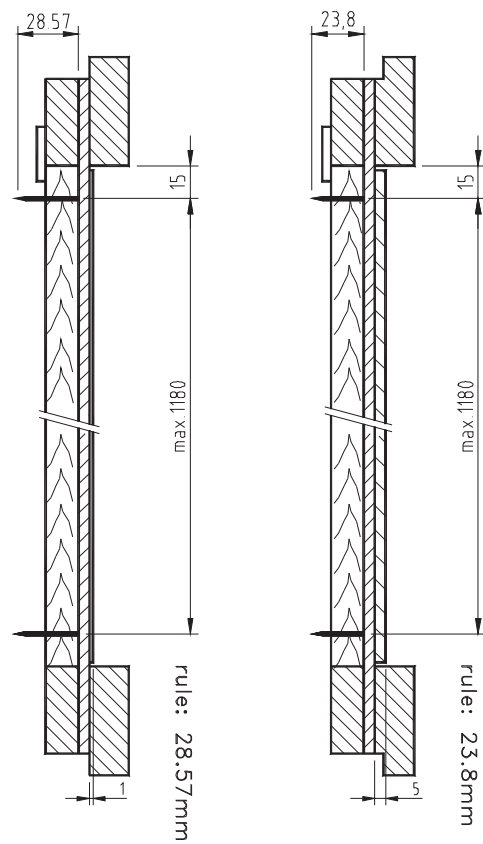
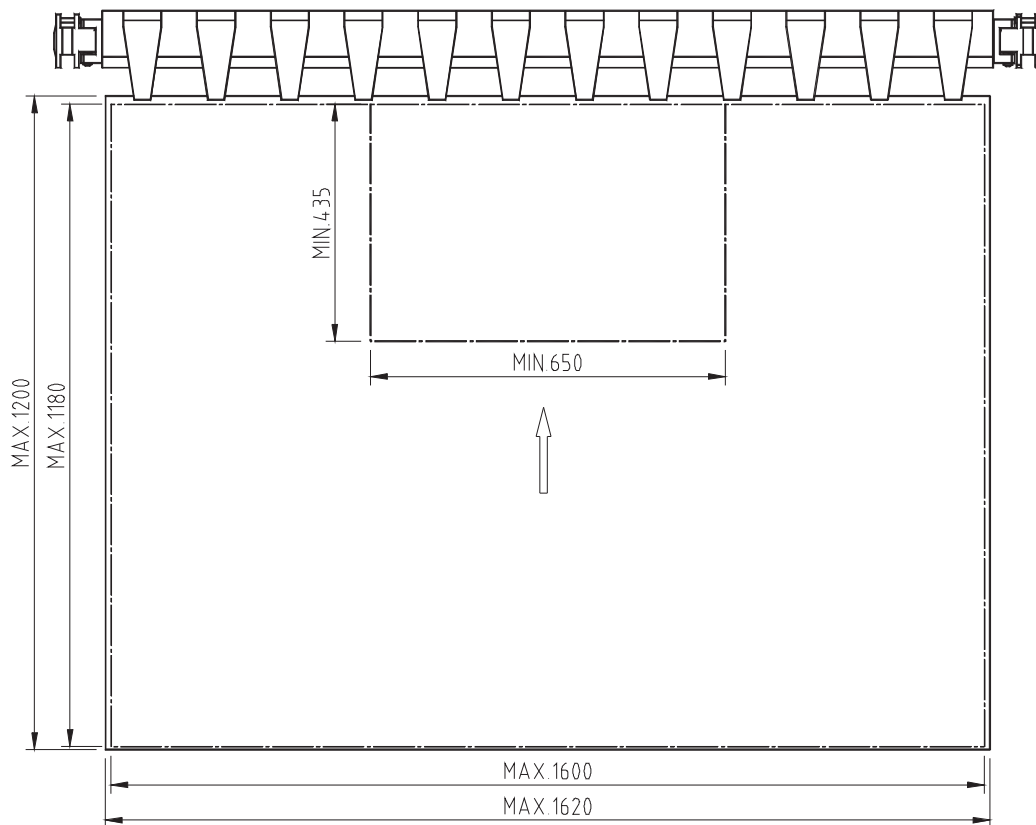

Fig. 6.1

6 DIECUTTER

6.1 GENERAL DESCRIPTION

6.1.1 General Operation(fig. 6.1)

The die is positioned on top and fitted on the upper platen.

The cutting plate is at the bottom, fitted on the movable platen.

The cutting force is adjusted by handwheel (fig. 6.2) shifting conical spacers located below the toggles.

6.1.2 Locking on Upper Chase

The upper chase is held by seven spring/air cylinder operated clamps actuated by locking push button (20).

6.2 CONTROL OF CUTTING FORCE

6.2.1 Description(fig. 6.2)

Force control handwheel.

Turn right to increase force.

Turn left to reduce force.

Important: The force can be adjusted when machine is running or at a standstill.

6.2.2 Cutting Force and Temperature Increase of Machine

With a given adjustment, the cutting force tends to increase as the machine warms up. Keep the force constant by handwheel.

6.3 PLATEN LOCKED UNDER PRESSURE

The platen may be locked under pressure in the following cases:

- An emergency stop (50) has been depressed.
- One of the personnel safety switches has been actuated.
- Too much pressure is applied.
- Electric breakdown.

Trouble Elimination

If the machine is locked under pressure, proceed as follows:

Try to release the platen by jogging. If the clutch slips after the jog button has been depressed a few seconds, do not insist, but move by hand. See 2.6 for manual drive.



Fig. 6.2

Impression hand wheel

6.4 DESCRIPTION OF DIE-CUTTING EQUIPMENT AND MATERIALS

6.4.1 General

The machine is to be delivered:

- For cutting rules of 23.8 mm or 28.57 mm. For board up to 9 mm.

6.4.2 Chase for 23.8 mm Rule or 28.57mm Rule

See fig. 6.3.

Suitable for solid and corrugated board up to 9mm. For using 28.57mm rule, to replace chase clamp rails of both sides. (fig. 6.3)

6.4.3 Cutting Dies

Timber: Hard plywood, 8 to 12 ply, thickness 15 mm.

Rubber: To extend beyond the cutting rules by 2 mm.

Cutting rules: -2 or 3 points for 23.8 mm.

-3 points for 28.57 mm.

Preferably use double-bevel (fig. 6.5): this facilitates penetration.

Creasing rules

Recommended thickness for corrugated board E: 3 points.

Recommended thickness for corrugated board A, B and C: 3 or 4 points.

Remark: Good results have been obtained with 3mm rules in the direction across the corrugations. With double-wall board, 2 creasing rules can be used as shown by fig. 6.6 & 6.7.

Height: to be determined according to fig. 6.6 & 6.7.

Die dimensions

For reasons of tightening in the chase, large dimension dies must be cut to the maximum size, that is:

Width in excess of 1600 mm: width of die: 1630 mm.

Length in excess of 1180 mm: length of die 1215 mm.

Interchangeability of dies

Cutting dies for 23.8 mm cutting rules prepared according to 6.4.3 can be fitted to PE1620SA-Extra.

6.5 FITTING OF DIE INTO CHASE

6.5.1 Position of Die

Longitudinally, the die is always mounted against the front edge of the frame (see fig. 6.4).

Laterally, the die must normally be centered in the chase.



Fig. 6.3

Chase clamp rails of both sides to be replaced using the 28.57mm high rule die.

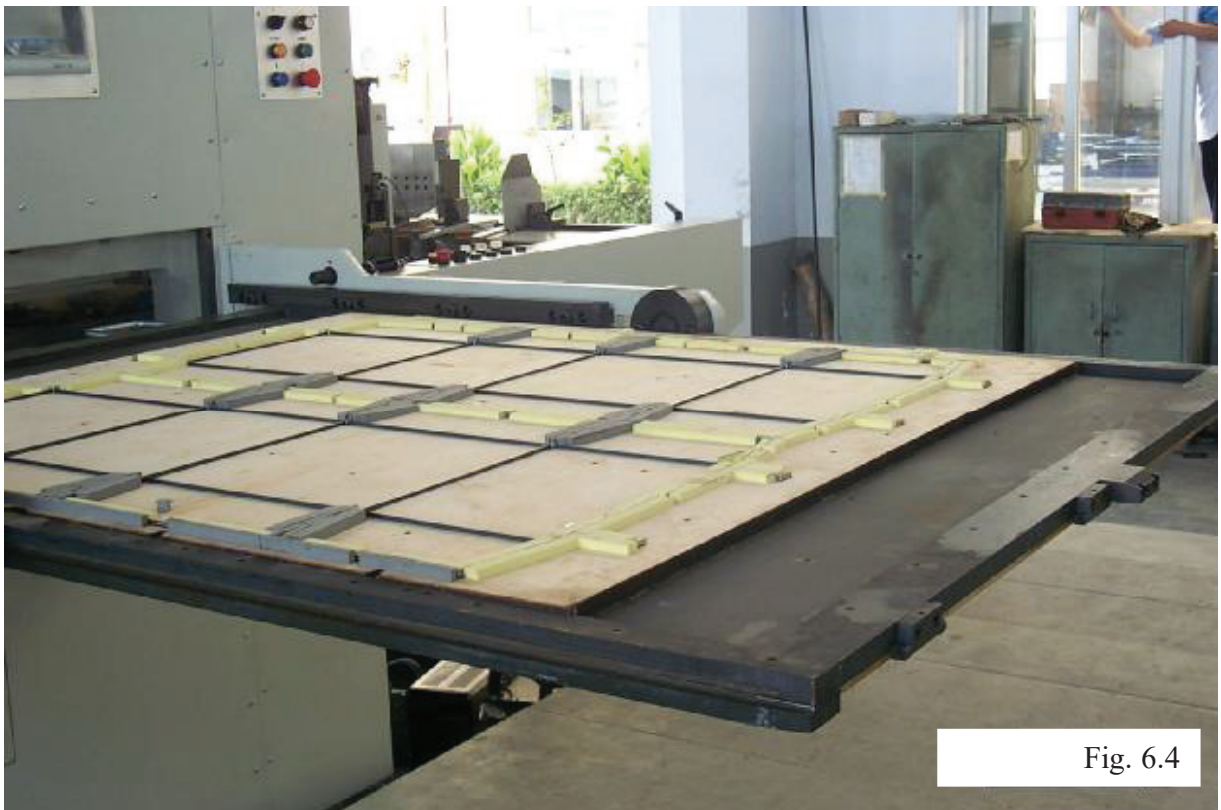

Fig. 6.4

Cutting die and die chase

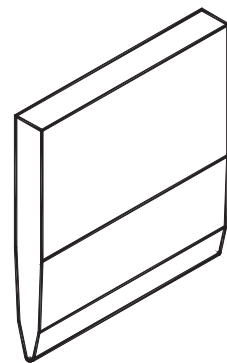
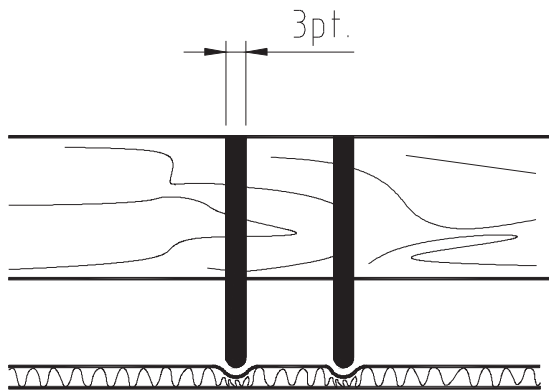
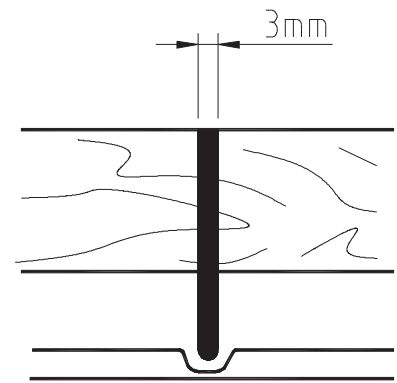
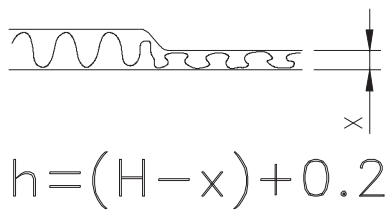
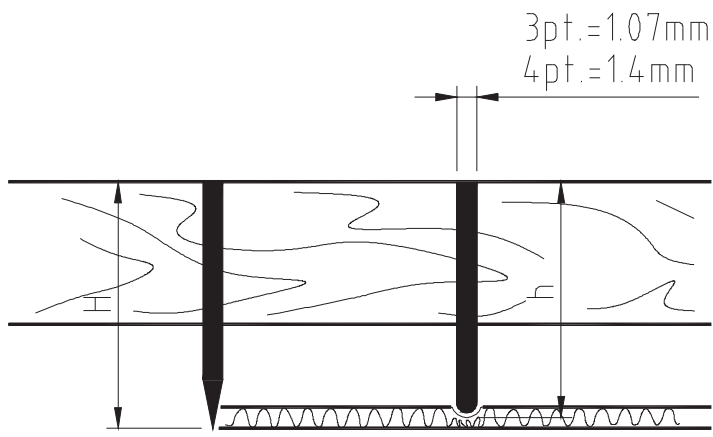

Fig. 6.5

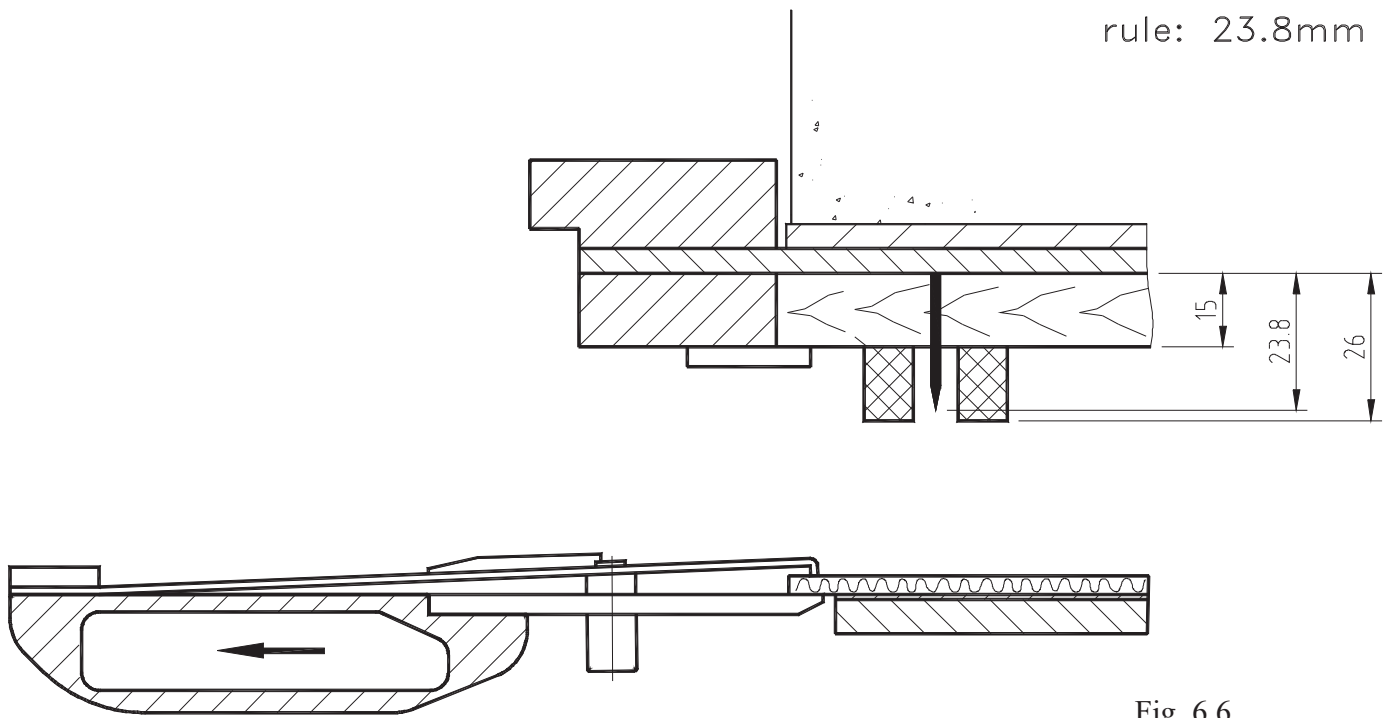

Fig. 6.6

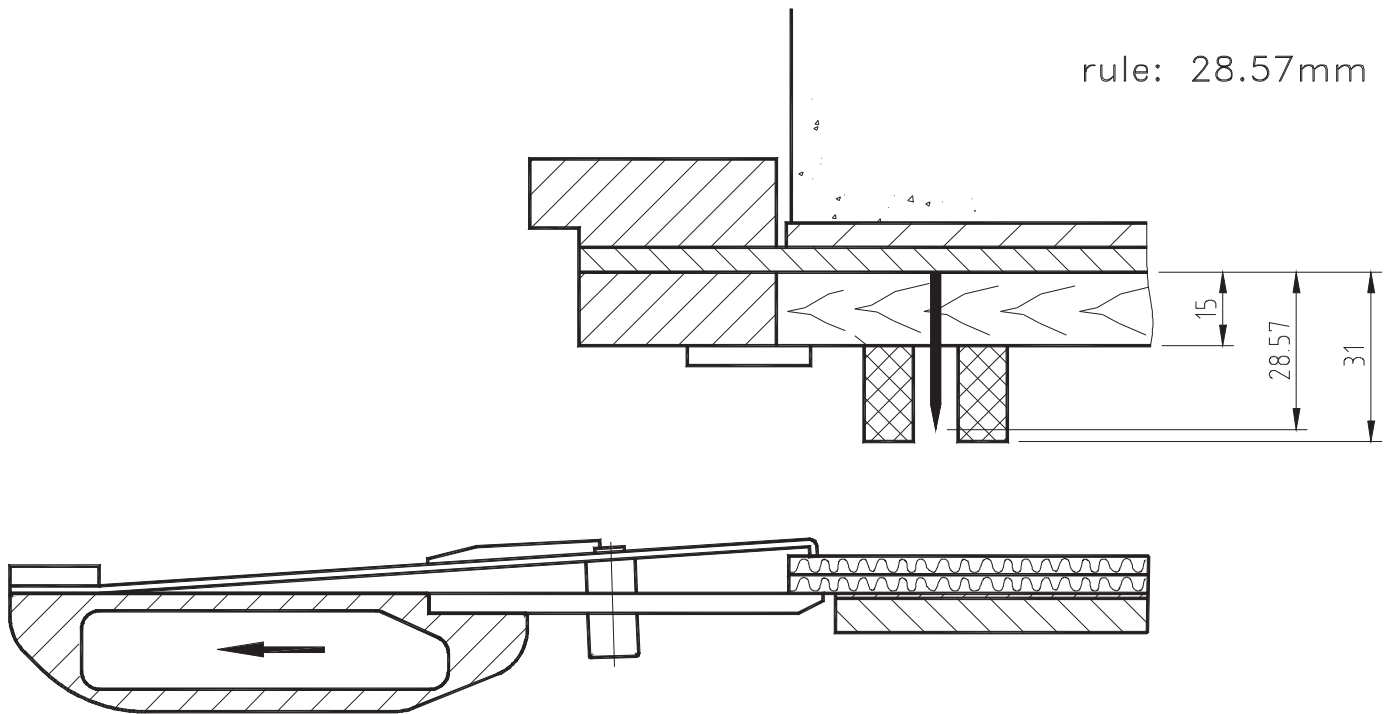

Fig. 6.7

6.5.2 Safety Screws

The bottom plate has holes for the passage of the screws used to secure the die to the chase as shown in fig. 6.8 as well as suitable kinds of screws.

The drawing at the end of chapter 6 shows all possible hole locations, which have to be known if the holes are drilled in advance, off the chase. (fig. 6.16)

6.5.3 Balancing of Platen (fig. 6.10)

If the die is shorter than 900 mm, fit a compensation die with some cutting rules as shown in fig. 6.10, in order to balance the platen.

6.6 HANDLING OF DIE-CUTTING EQUIPMENT

6.6.1 How to Put the Chase in Place

1. Set the platen in lower position –open the transparent guard.
2. Lift the chase with a hoist using the appropriate handles and put on to the chase supporting arm.
3. Engage the two pivot bolts.
4. Take off the lifting handle.
5. Turn the chase over rules upwards and engage it between the safety finger pins on both sides.
6. Mount the cutting die.
7. Turn the chase over.
8. Release the safety pins.
9. Push the die chase completely into the cutting station.
10. Depress the push button 20.
11. Close the safety lock.

6.6.2 How to Pull the Chase out

1. Set the platen in lowest position open the transparent guard.
2. Depress the push button 20 to unlock.
3. Open the safety lock.
4. Pull the chase out.

6.6.3 How to Remove the Cutting Plate

1. Depress push button 21 to move the gripper bar to 180 position.
2. Open the transparent guard.



Fig. 6.8

Screw used to secure the die to the chase



Fig. 6.9

Die chase and supporting arm

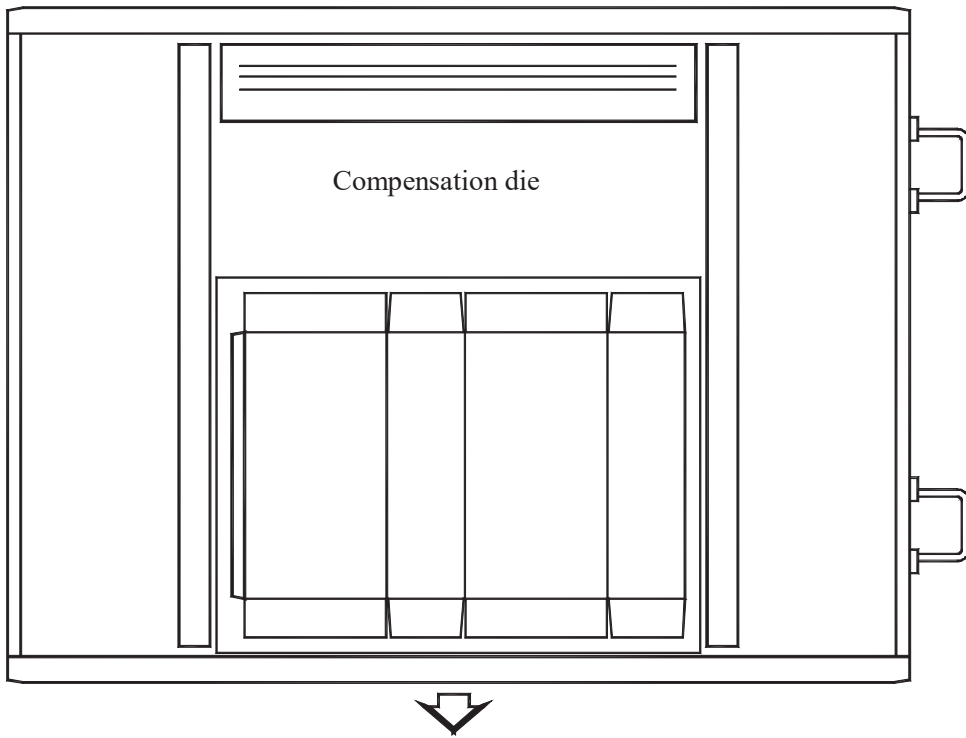
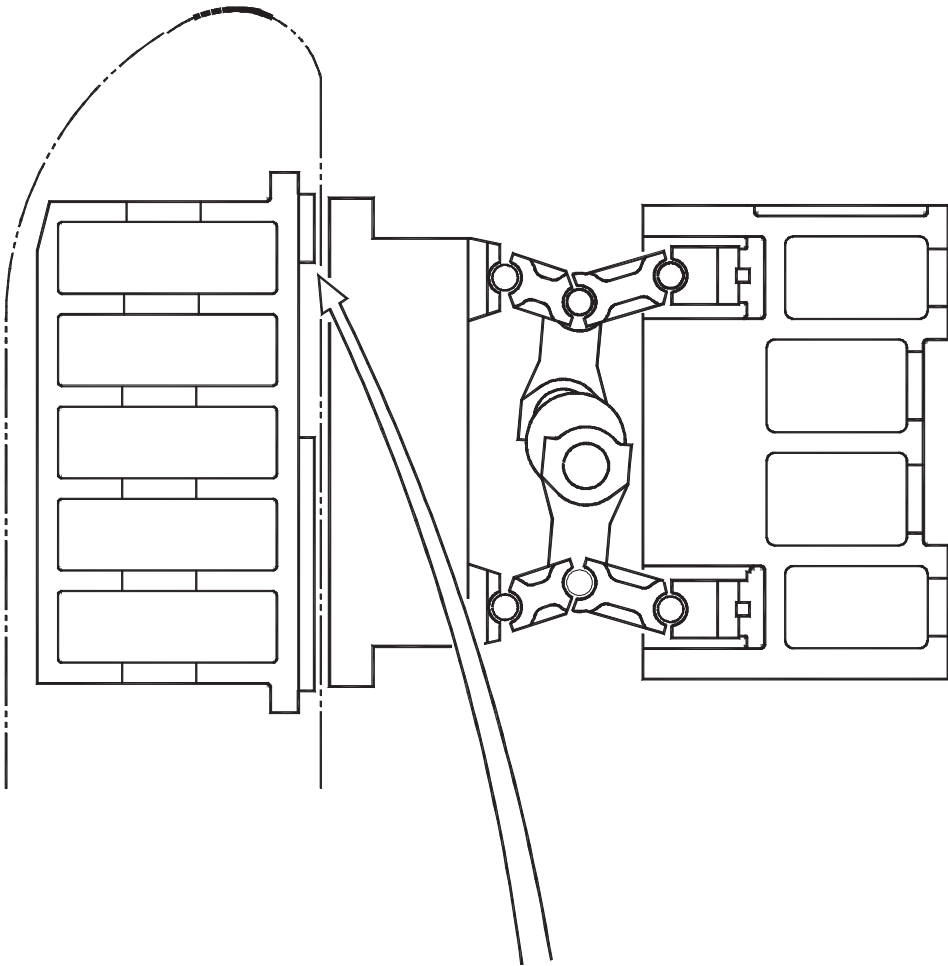

3. Open the safety lock. (fig. 6.17)
4. Flip out the both cutting plate supporting rail on the supporting arm , and lift up the air cushion on/off handle (fig. 6.9).
5. Pull the cutting plate out.

6.7 MAKE-READY

Any cutting work requires a fine height adjustment of the cutting rules according to the result of the first cutting test, when about 80% of the pattern are cut correctly.

This adjustment is called make-ready and is carried out with gummed paper to be glued on the back of the make-ready plate. Two rolls of make-ready paper of two thicknesses are provided with the equipment, i.e. 0.04 and 0.1 mm (0.0016 and 0.004). In order to have the strips glued at correct location, i.e. where the cut is too weak, it is necessary to use a setting sheet, on which the outline of the cutting rules is marked out.

The make-ready sheet must be of kraft paper and may be prepared in several ways, some examples of which are mentioned here:

- a) Make-ready sheet prepared by the die-maker when composing the die. Before fitting the rubber, it is easy to transfer the outline of the cutting rules by carbon paper.
- b) Make-ready sheet prepared by the operator from a die-cut sheet which is used as a pattern for outlining the cutting rules.
- c) Make-ready sheet prepared by the operator, by carbon paper transfer inside machine.

Proceed as follows:

1. Set the cutting force to 5 or 10 tons by turning the cutting pressure adjusting wheel.
2. Put the following materials on the cutting plate.
 - a make-ready sheet
 - a carbon paper, coating downwards
 - a thin cardboard .
3. Operate the press once. The make-ready sheet then carries the mark of the cutting rules and can be used as described above.

Positioning of make-ready sheet

To place the make-ready sheet in register with the cutting rules, check the distances between the frame edge and cutting rules and position of the sheet accordingly. Secure the make-ready sheet to the corners with gummed paper.

6.8 CREASING COUNTERPARTS

6.8.1 Work without Counterpart

Most jobs are carried out without a creasing counterpart.

The board is simply crushed against the creasing plate. This is not suitable for solid board.

6.8.2 Working with Counterparts

Creasing counterparts are:

- essential for solid board.
- necessary for E-flute corrugated.
- recommended for B-flute corrugated for production of boxes to be transferred to folder-glueers. Especially for the following boxes (fig. 6.12-fig. 6.13).
- with crash-lock bottom (A).
- with 4-6 glued corners (B).

6.8.3 Production of the Counterpart

“Channel” system

This system consists of strips composed of a plastic guide and the counterpart, which is self-adhesive (fig. 6.14).

These strips must be cut to the length of the creasing rules and fixed on the latter (fig. 6.11).

After that, all you have to do is to remove the protective paper and then introduce the die and the cutting plate into the machine and operate the press once (B).

The plastic guides and the adhesive strip can then be removed and production may begin (C-D).

Advantage of the method: quick and easy to use, the system does not require an impression of the cutting die.

For dimensions according to cardboard type, consult the manufacturer.

Other system:

The counterparts can be made of pressboard (fig. 6.15) glued on the cutting plate. This requires an impression of the cutting die, to be carried out with carbon paper applied directly on the cutting plate.

Proceed as follows:

Put the following materials on the cutting plate: A carbon paper, coating downwards; A board, slightly thicker than the difference between the cutting rules and the creasers.

Operate the press once. The outline obtained on the plate makes it possible to shape the pressboard.

The thickness of the pressboard and the width of the grooves depend on the thickness of the layers of corrugated and cannot be defined theoretically.

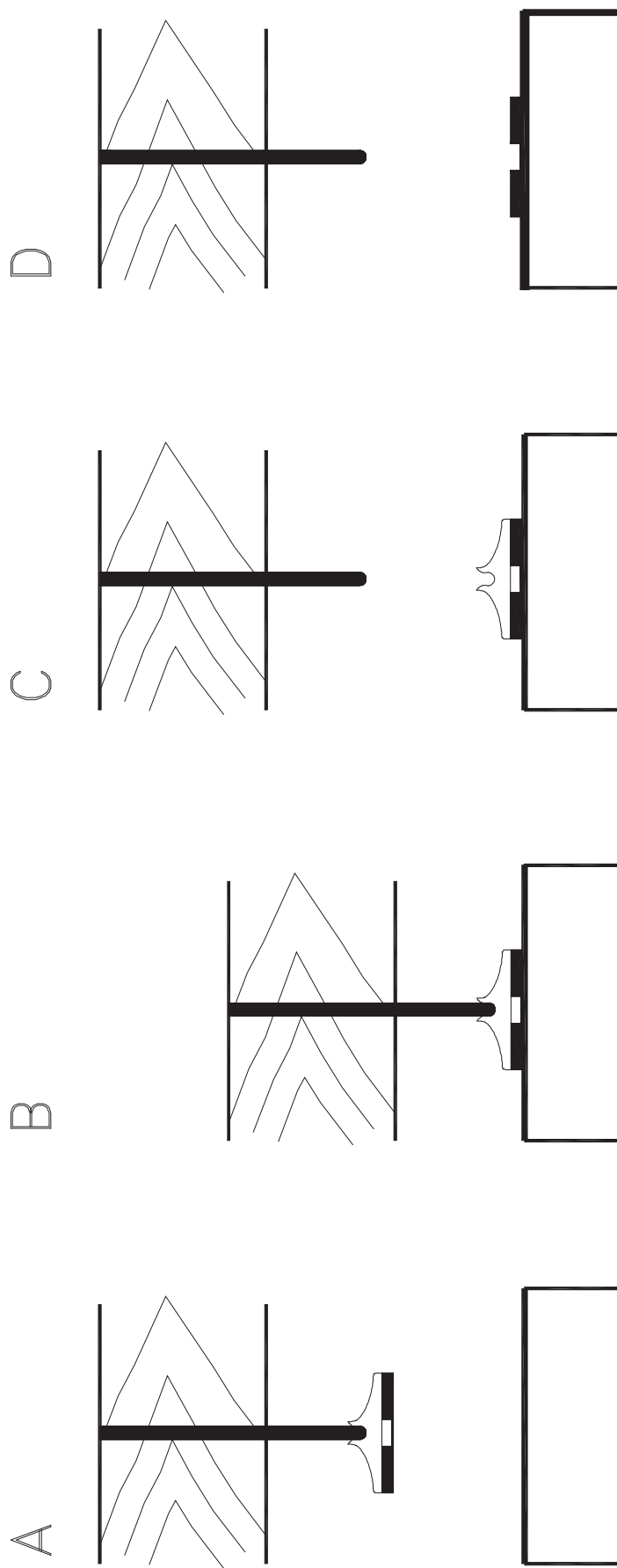

Fig. 6.11 Creasing counter

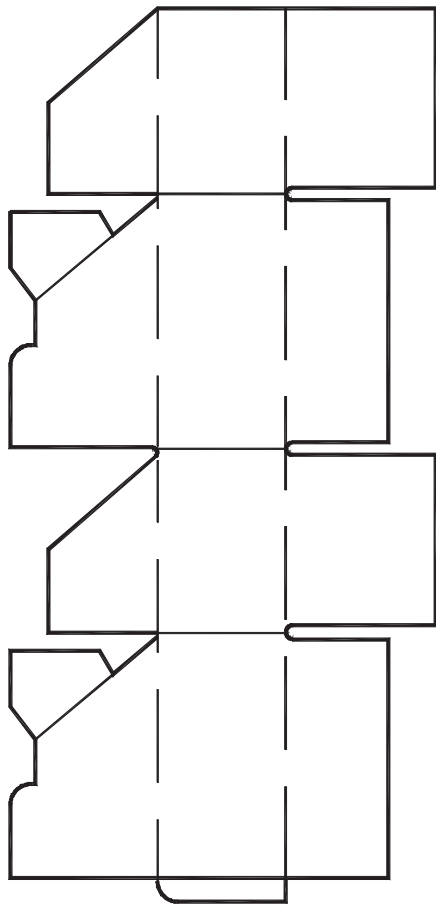

Fig. 6.12

A. Crash-lock bottom box

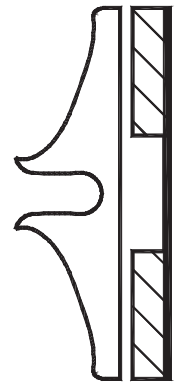

Fig. 6.14

Counterpart "Channel" system

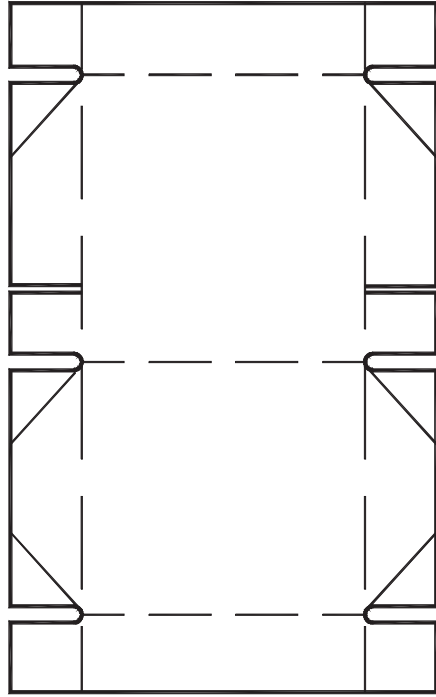

Fig. 6.13

B. 4-6 glued corner box



Fig. 6.15

Counterpart made of pressboard

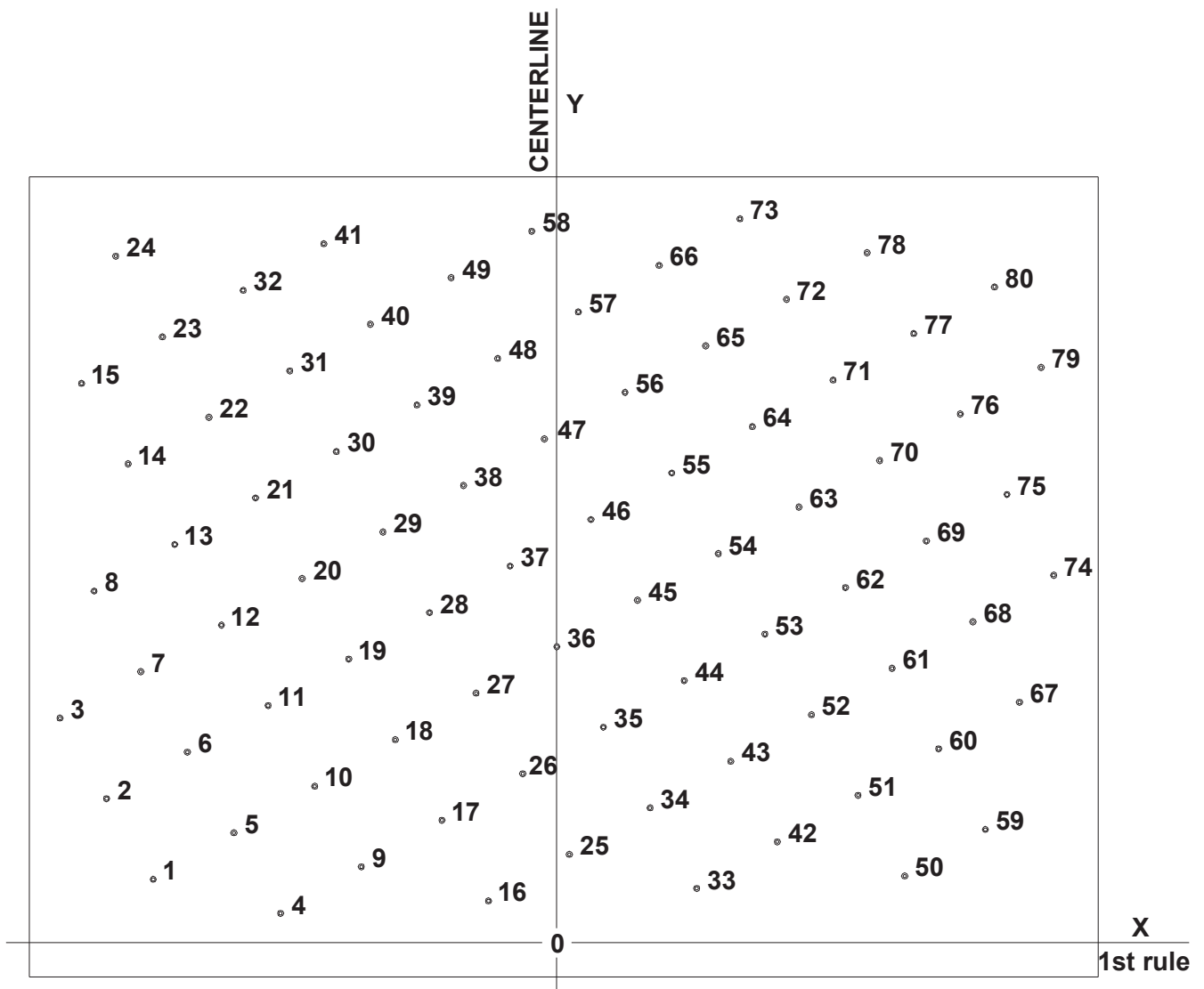

Drawing of possible screw hole location pattern..Fig.6.16

PE1620SA-Extra

N*	X	Y	N*	X	Y	N*	X	Y
1	-649.5	102.4	35	75	347.5	69	594.6	647.5
2	-724.5	232.3	36	0	477.4	70	519.6	774.4
3	-799.5	362.2	37	-75	607.3	71	444.6	907.3
4	-444.6	47.5	38	-150	737.2	72	369.6	1037.2
5	-519.6	177.4	39	-225	867.1	73	294.6	1167.1
6	-594.6	307.3	40	-300	997	74	799.5	592.6
7	-669.6	437.2	41	-375	1126.9	75	724.5	722.5
8	-744.6	567.1	42	354.9	162.7	76	649.5	852.4
9	-314.7	122.5	43	279.9	292.6	77	574.5	982.3
10	-389.7	252.4	44	204.9	422.5	78	499.5	1112.2
11	-464.7	382.3	45	129.9	552.4	79	799.4	927.4
12	-539.7	512.2	46	54.9	682.3	80	704.4	1057.3
13	-614.7	642.1	47	-20.1	812.2			
14	-689.7	772	48	-95.1	942.1			
15	-764.7	901.9	49	-170.1	1072			
16	-109.8	67.7	50	559.8	107.8			
17	-184.8	197.5	51	484.8	237.7			
18	-259.8	327.4	52	409.8	367.6			
19	-334.8	457.3	53	334.8	497.5			
20	-409.8	587.2	54	259.8	627.4			
21	-484.8	717.1	55	184.8	757.3			
22	-559.8	847	56	109.8	887.2			
23	-634.8	976.9	57	34.8	1017.1			
24	-709.8	1106.8	58	-40.2	1147			
25	20.1	142.6	59	689.7	182.8			
26	-54.9	272.5	60	614.7	312.7			
27	-129.9	402.4	61	539.7	442.6			
28	-204.9	532.3	62	464.7	572.5			
29	-279.9	662.2	63	389.7	702.4			
30	-354.9	792.1	64	314.7	832.3			
31	-429.9	922	65	239.7	962.2			
32	-504.9	1051.9	66	164.7	1092.1			
33	225	87.7	67	744.6	387.7			
34	150	217.6	68	669.6	517.6			

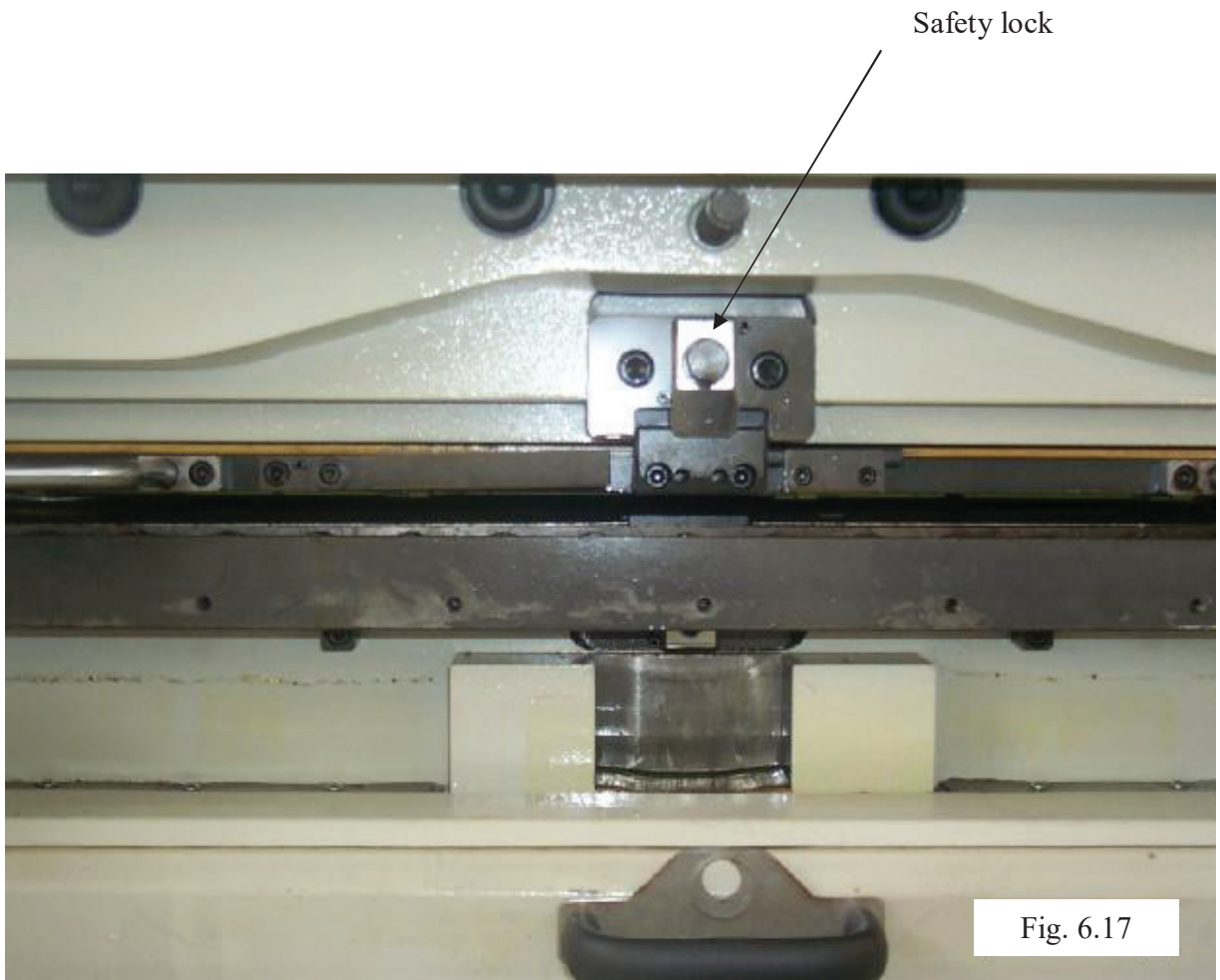

Safety lock

Fig. 6.17

6.8.4 Die cutting with gripper bite waste breaking knife

- 1) Extend any of the longitudinal cutting rules to the edge of the cutting chase to break gripper bite waste. Several longitudinal cutting rules can be extended and located in necessary spots. (Fig6.18)
- 2) Remove the up gripper springs and gripper seats off the gripper bars to where the cutting knife will locate and to fit gripper tip filler PB20312 to the notch. (Fig6.19)

Attention:

- 1、 The materials of gripper tip sitting cross bar and gripper tip filler are the same as that of the cutting plate which are of HRC50 hardness for taking the cutting pressure.
- 2、 Using PB20309, PB20310 and PB20311 as gripper tip sitting cross bar when the thickness of the cutting plate is 7 mm or 6+1 mm.
- 3、 Using PB20322, PB20323 and PB20324 as gripper tip sitting cross bar when the thickness of the cutting plate is 7+1 mm.
- 4、 6 mm cutting plate cannot be used alone.

See Fig6.20: procedure of fitting gripper tip sitting cross bar and gripper tip filler.

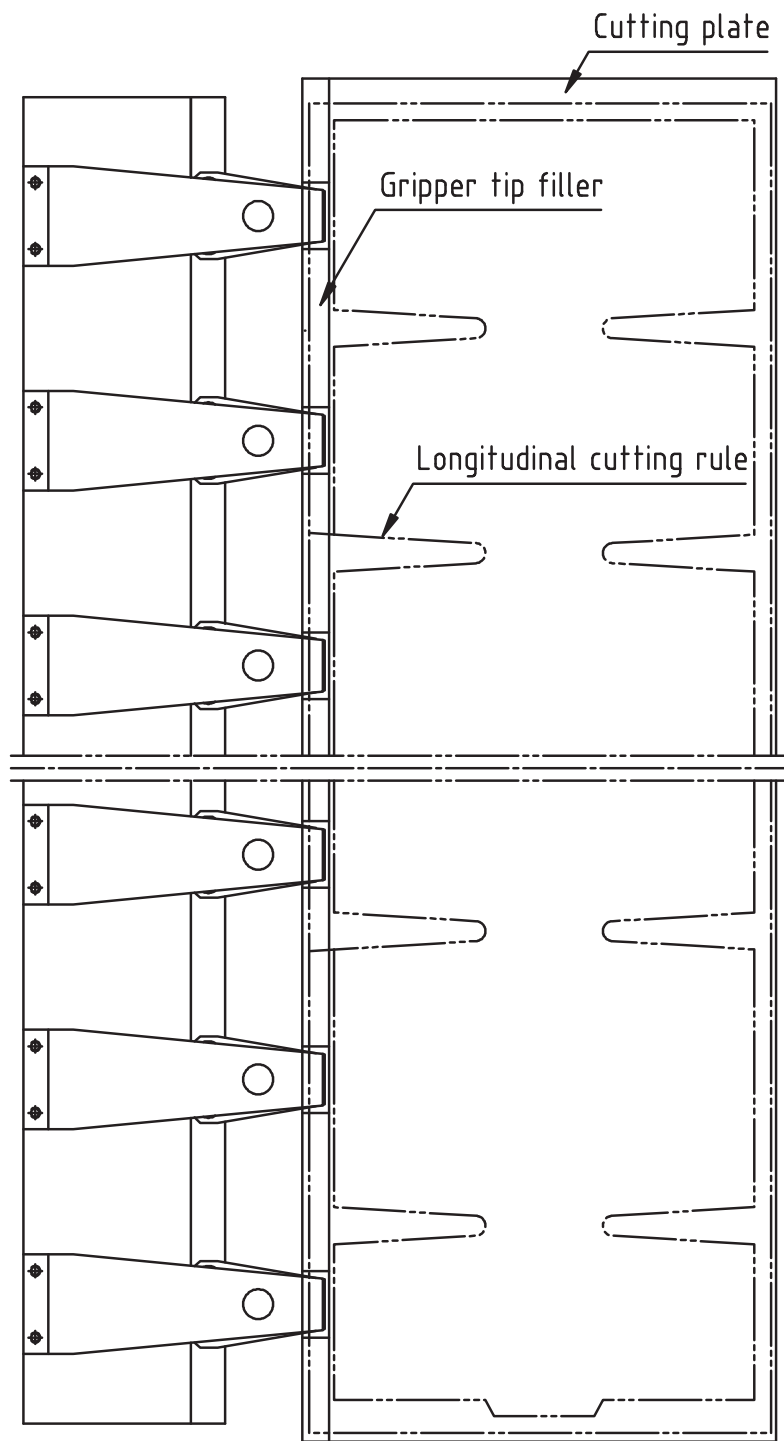

Fig 6.18

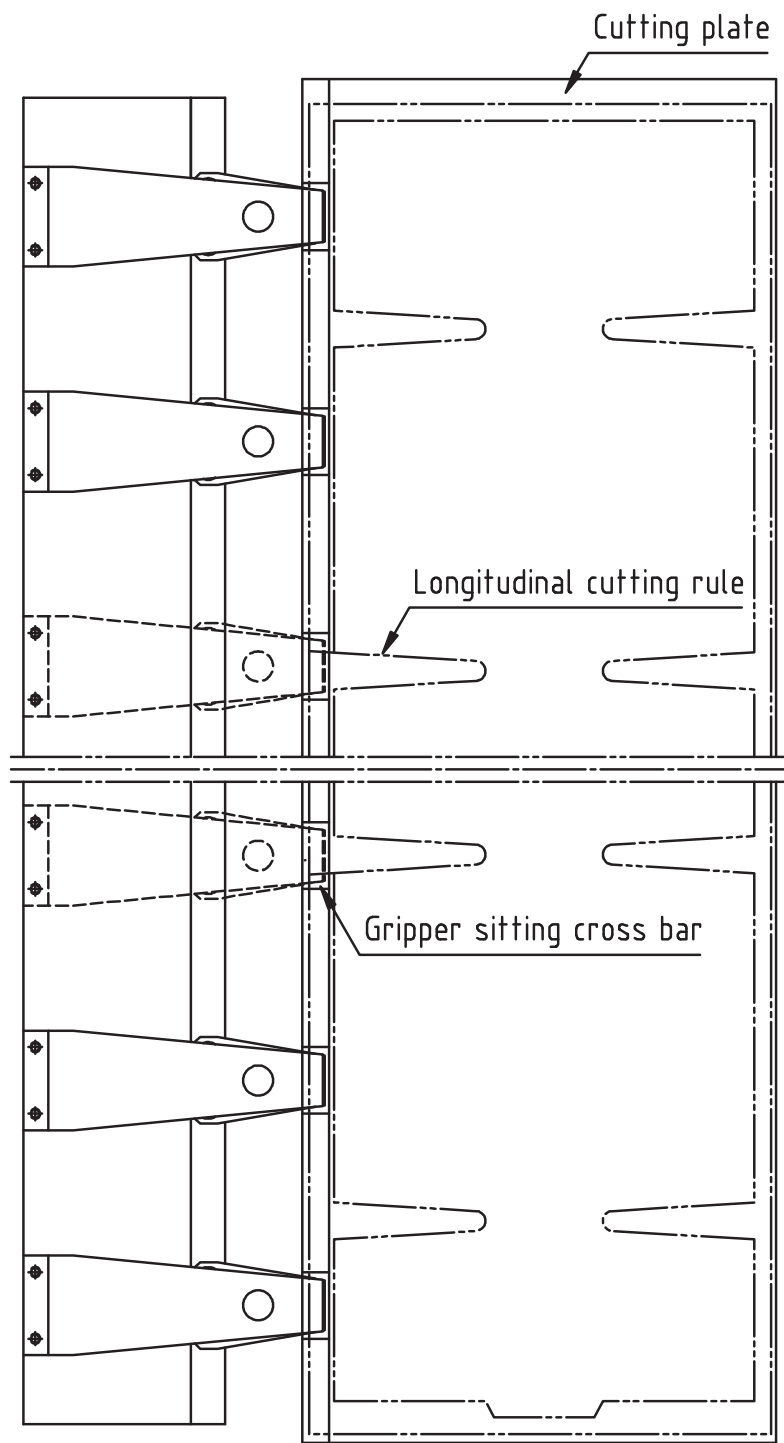

Fig 6.19

6.8.5 Die cutting without gripper margin

- 1) Extend the longitudinal cutting rules to the edge of the cutting chase. (Fig 6.21)
- 2) Remove the up gripper springs and gripper seats off the gripper bars to where the cutting knife will locate and to fit gripper tip filler PB20312 to the notch. (Fig 6.22)

Attention:

- 1、 The materials of gripper tip sitting cross bar and gripper tip filler are the same as that of the cutting plate which are of HRC50 hardness for taking the cutting pressure.
- 2、 Using PB20309, PB20310 and PB20311 as gripper tip sitting cross bar when the thickness of the cutting plate is 7 mm or 6+1 mm.
- 3、 Using PB20322, PB20323 and PB20324 as gripper tip sitting cross bar when the thickness of the cutting plate is 7+1 mm.
- 4、 6 mm cutting plate cannot be used alone.

See Fig6.20: procedure of fitting gripper tip sitting cross bar and gripper tip filler

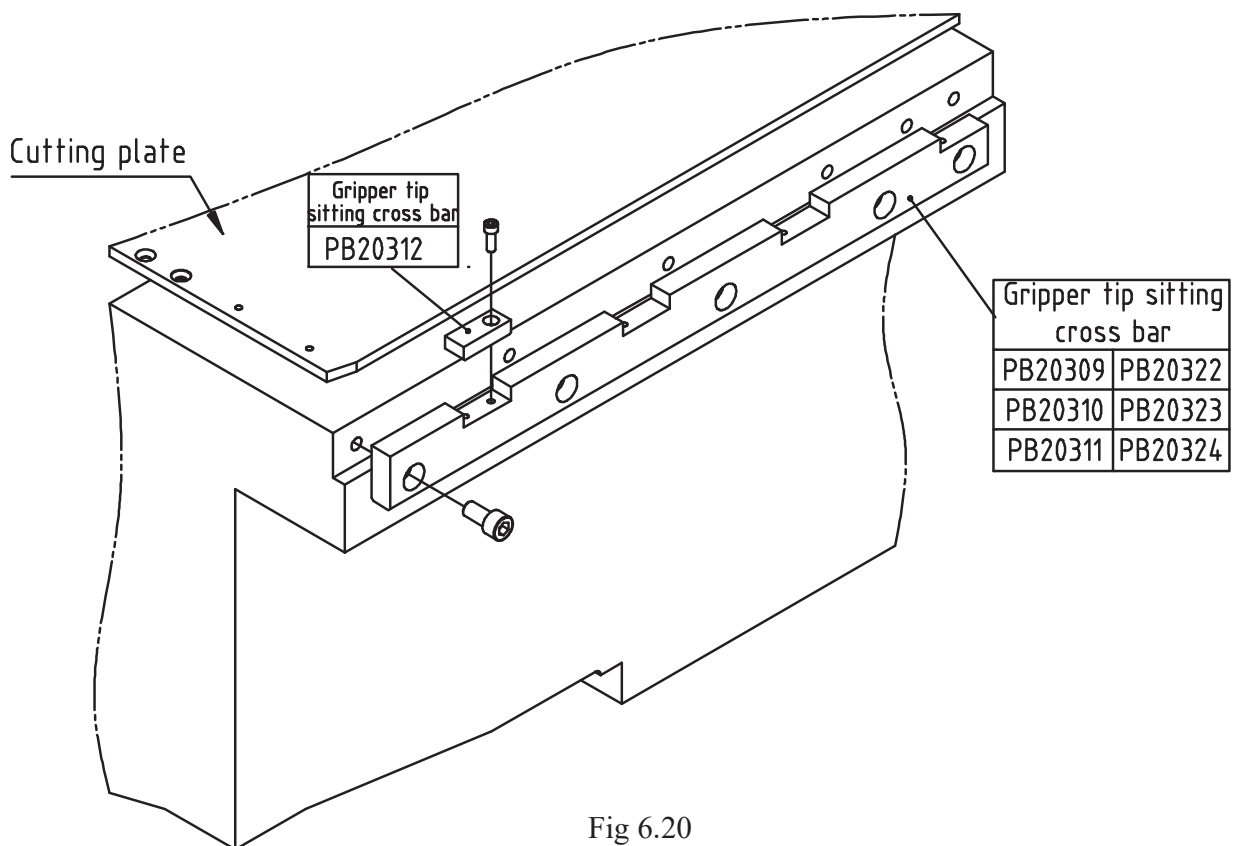

Fig 6.20

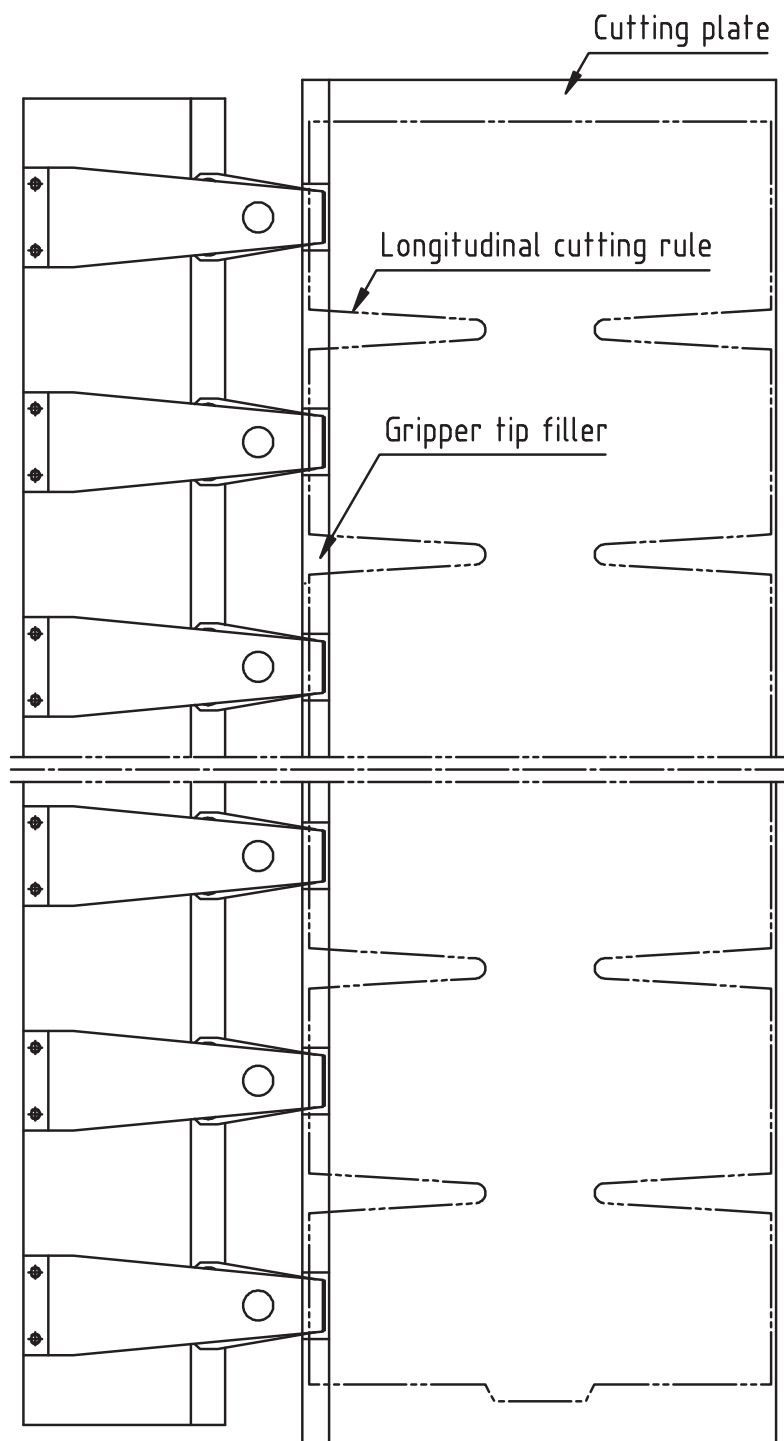

Fig 6.21

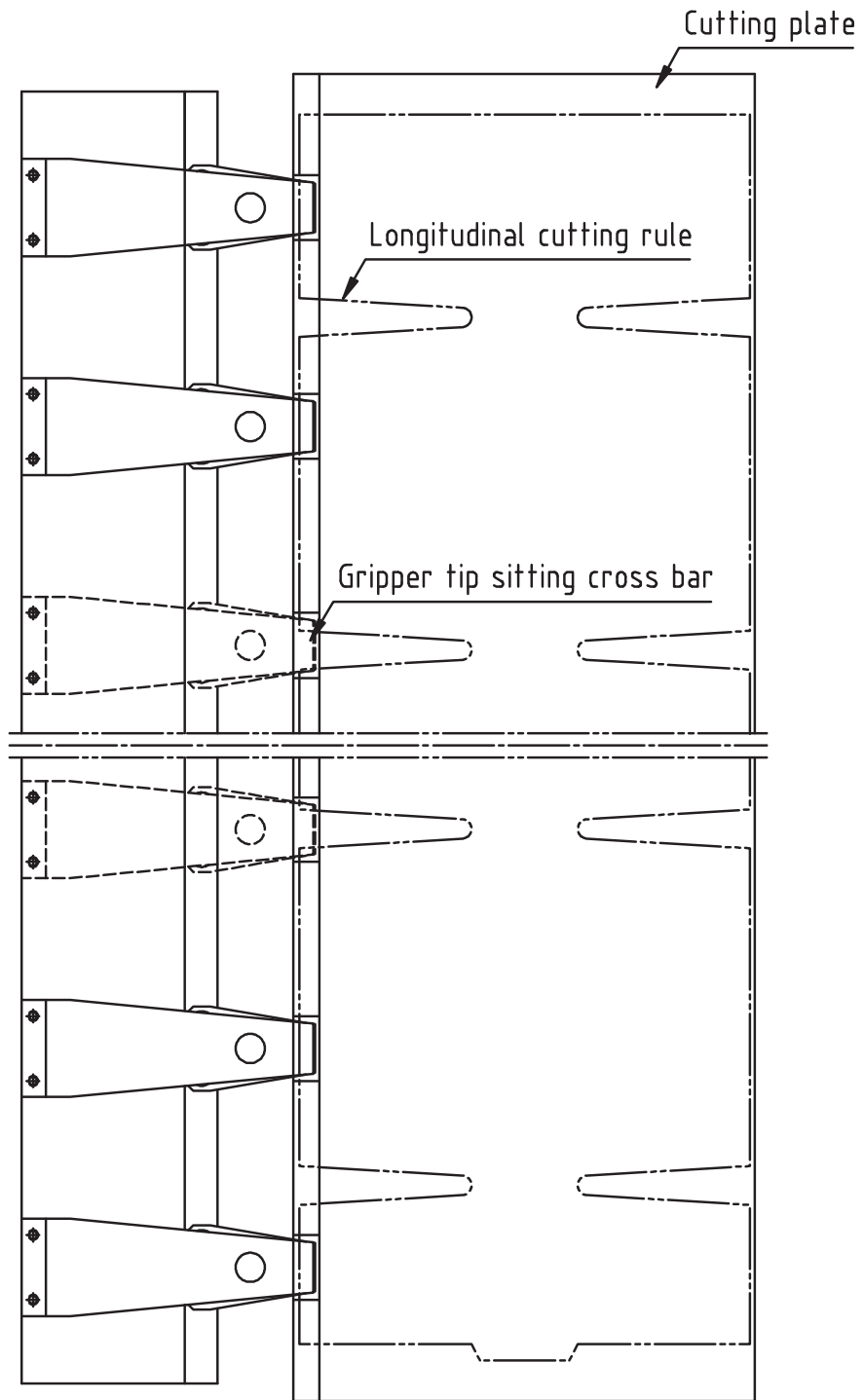

Fig 6.22

ETERNA

INSTRUCTIONS
PE1620SA-Extra

Chapter 7

STRIPPER

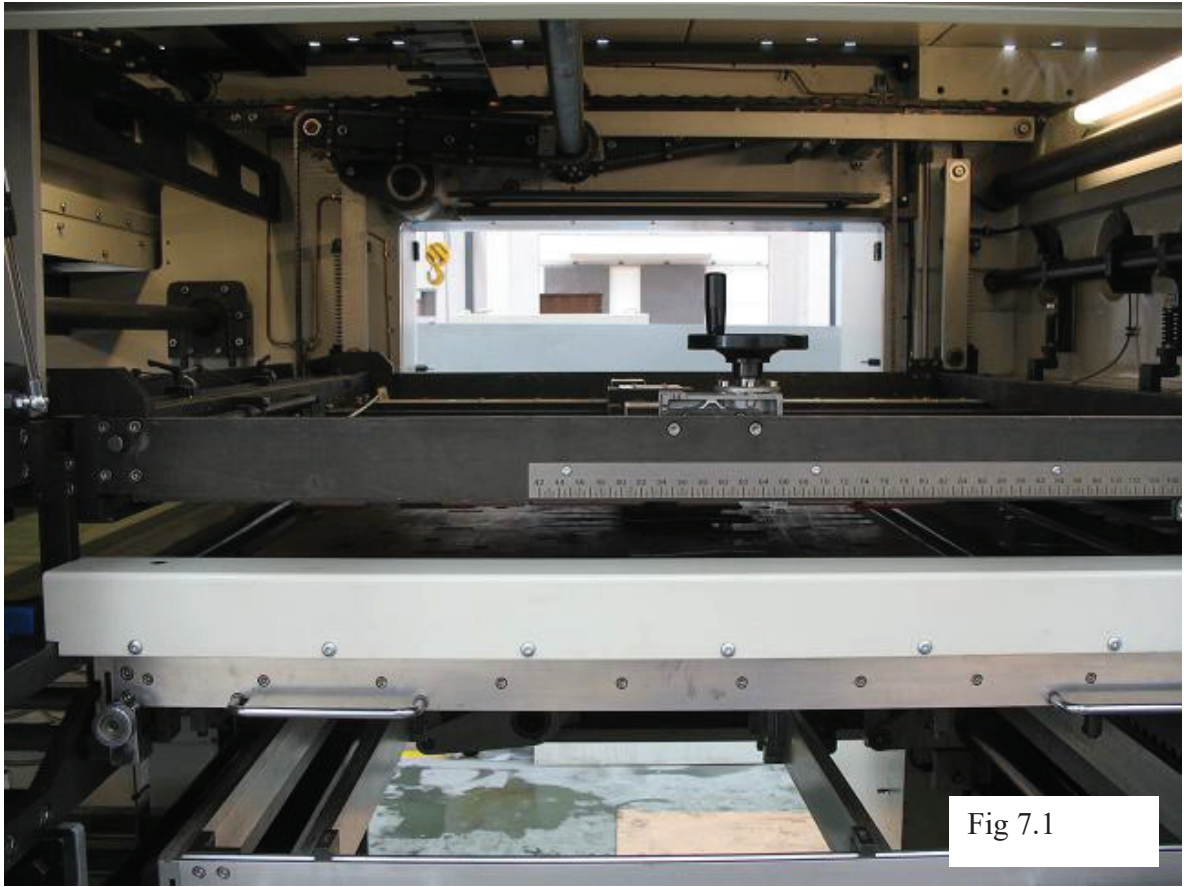

Fig 7.1

International center line system

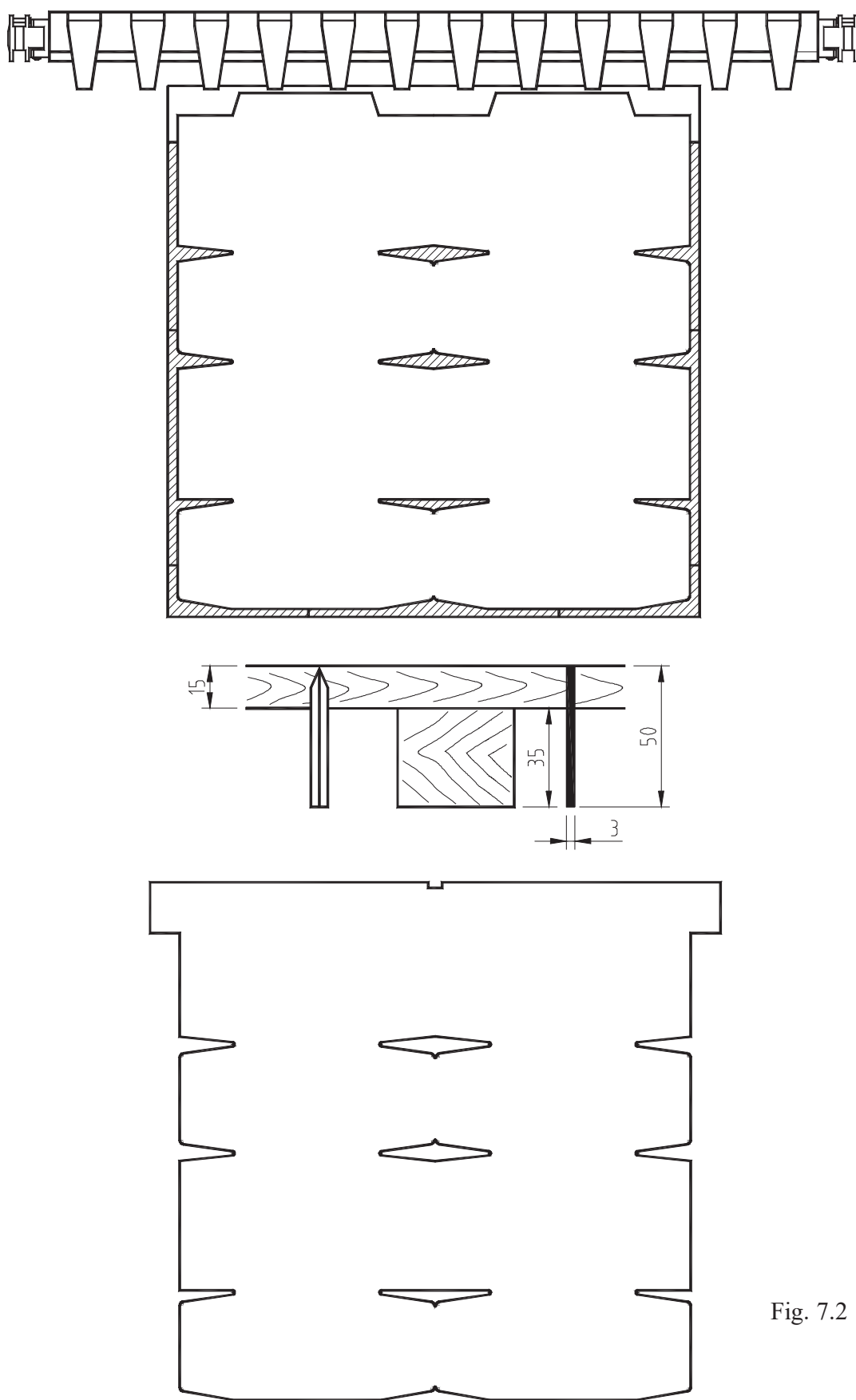

Fig. 7.2

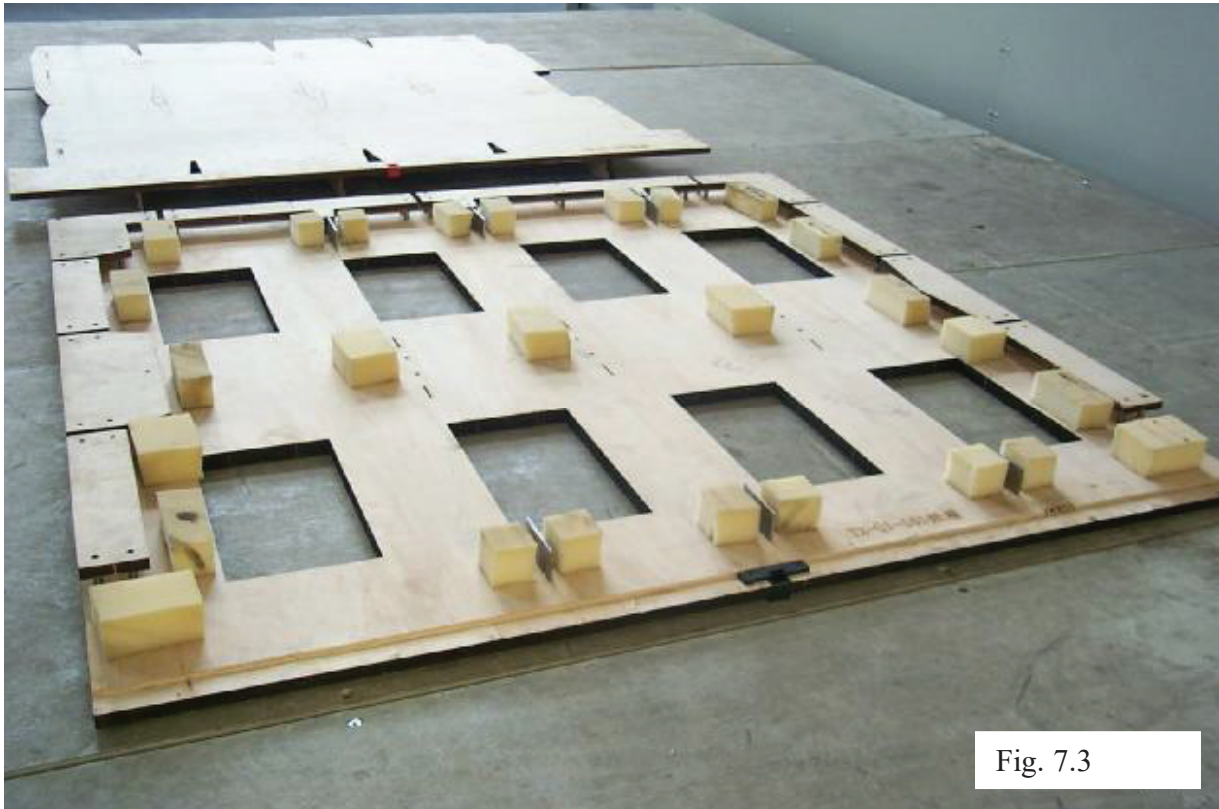

Fig. 7.3

Male (upper) stripping board



Fig. 7.4

Fitting of female stripping board

7. STRIPPER

7.1 DESCRIPTION (fig. 7.1 & fig. 7.2)

7.1.1 Operation

The stripping station consists of a upper frame, on which a male tool is fitted, and a lower movable frame holding a female stripping board, to be cut according to the waste outlines. When the gripper bar stops, the sheet is pushed by the stripping board and the upper tool, the waste pieces are stripped off through the openings in the board (fig. 7.3).

As shown on fig. 7.1 & fig. 7.2, it is possible to strip side trims and rear trim and also the waste inside the sheet.

There are two types on upper tools:

- the stripping pins.
- the stripping dies to be prepared by the die-maker together with the female stripping board and the cutting die.

7.1.2 Female Stripping Board(fig. 7.4)

Material: Hard plywood, thickness 12 mm.

To be manufactured by the die-maker together with the cutting die.

7.1.3 Stripping Pins(subject to different models)(fig. 7.5)

Supplied with the machine, these tools are designed to be fastened directly on the cross bars. They are available in two different lengths.

Use: Especially appreciated for single jobs, limited runs, or large runs of simple work.

Advantages: No need to make a die, easy storage in a small space.

7.1.4 Stripping Dies (fig. 7.2 & fig. 7.3)

Material: Hard plywood, thickness 15 mm ($\frac{5}{8}$ ").

Further possibilities are to use either wooden blocks, 35 mm high and nailed on the die, or sheet metal plates of 50x 3 mm, to be inserted into die.

Application: A stripping die is to be manufactured for repeated jobs, for large runs and for all complicated work.

Advantage: Very short make-ready time.

The stripping die should be manufactured by the die-maker at the same time as the cutting die.



Stripping pin

7.1.5 Pressing Pads

Material: synthetic foam (i.e. polyether or polyester),

Thickness: -without stripping die: 40 mm (1"-1/2").

Good results have been obtained with foam densities located between 35-40 kg/m³ (2.2 to 2.5 lb/cu.ft)

In order to have strips usable in both cases, cut 55 mm wide strips out of 40 mm foam. Then you need only to glue them on their narrow or broad side, depending on the needed height.

Use: To keep the sheet against the stripping board when the waste is stripped.

7.2 RISE AND DESCENT OF STRIPPING FRAME

Rise: Depress the push button 55 and keep pressing. The frame rises up to its end of stroke. Inoperative during machine run.

Stop during rise: Release depressing the push button 55. The frame re-descend a little until it

stops in a notch of the ratchet wheel.

Descent: Depress the push button 56 and keep pressing. In lower position, the frame is automatically locked.

7.3 FITTING OF FEMALE STRIPPING BOARD(fig. 7.4)

7.3.1 Description (fig. 7.6 & fig. 7.7)

The lower stripping die is directly delivered to the lower frame of the lower stripping tool, and the left/right position is determined by the center positioning block.

7.3.2 Mounting the Female Board on the Press

1. Push the stripping chase to the end and close the safety lock.
2. Feed a sheet into the machine, cut it, then move it forward over the female board until the latter reaches its upper position.
3. Adjust the position of the board according to the sheet, strip the waste by hand, and then adjust accurately.
4. Tighten all the straps .

7.3.3 Detaching the Back Trim from the Side Trims

As shown on fig. 7.8, it is necessary to have a lower support at the location of cut separating the back trim from the side trim. This support can be realized by the detaching devices fit with a piece of cutting rule (preferably 28.6 mm). It is also possible to manufacture special parts to be screwed on the plate.



Fig. 7.6



Fig. 7.7

Female (middle) stripping board

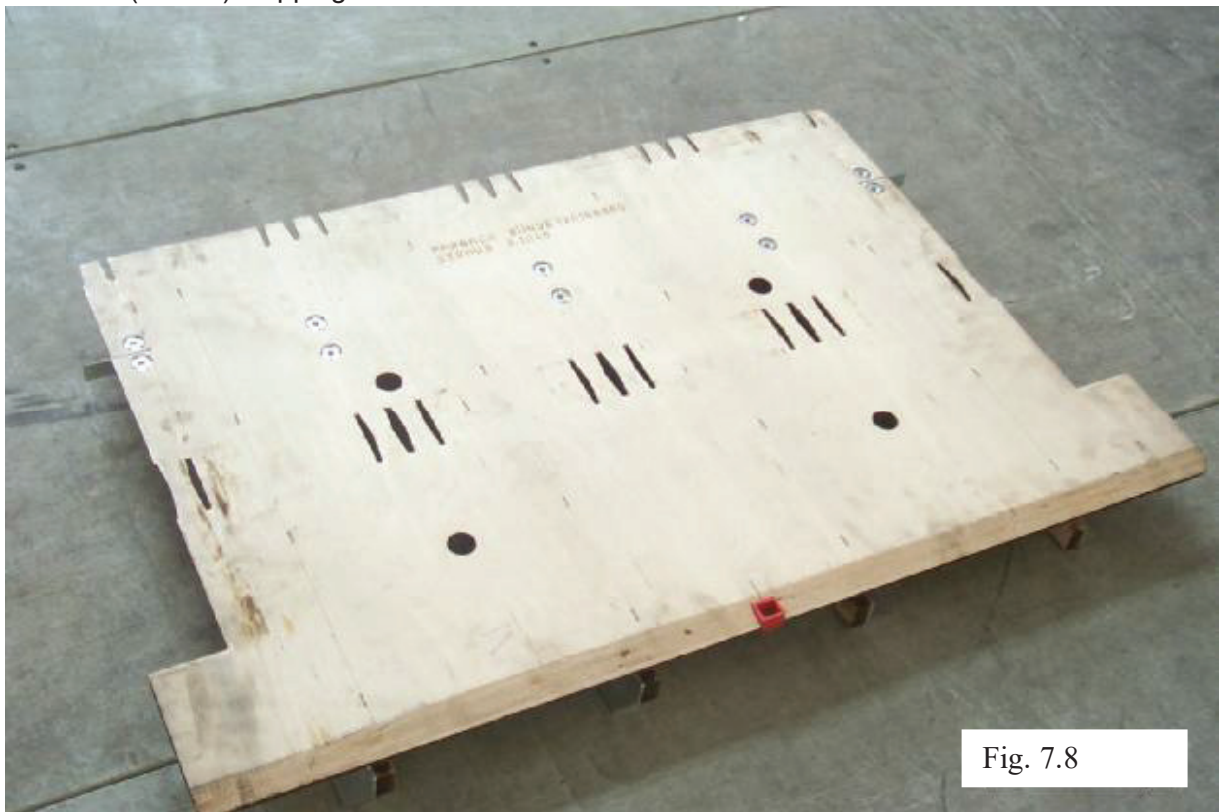

Fig. 7.8

Lower support for back trim cut separating

7.4 Diecut WITHOUT STRIPPING

When diecutting without stripping, to lock a woodboard in the lower stripping frame to support the sheet traveling over.

ETERNA

INSTRUCTIONS

PE1620SA-Extra

Chapter 8

DELIVERY



Fig. 8.1



Fig. 8.2

Upper tool carrier crossbar



Fig. 8.3

Pulling the upper tool carrier crossbar out.



Fig. 8.4

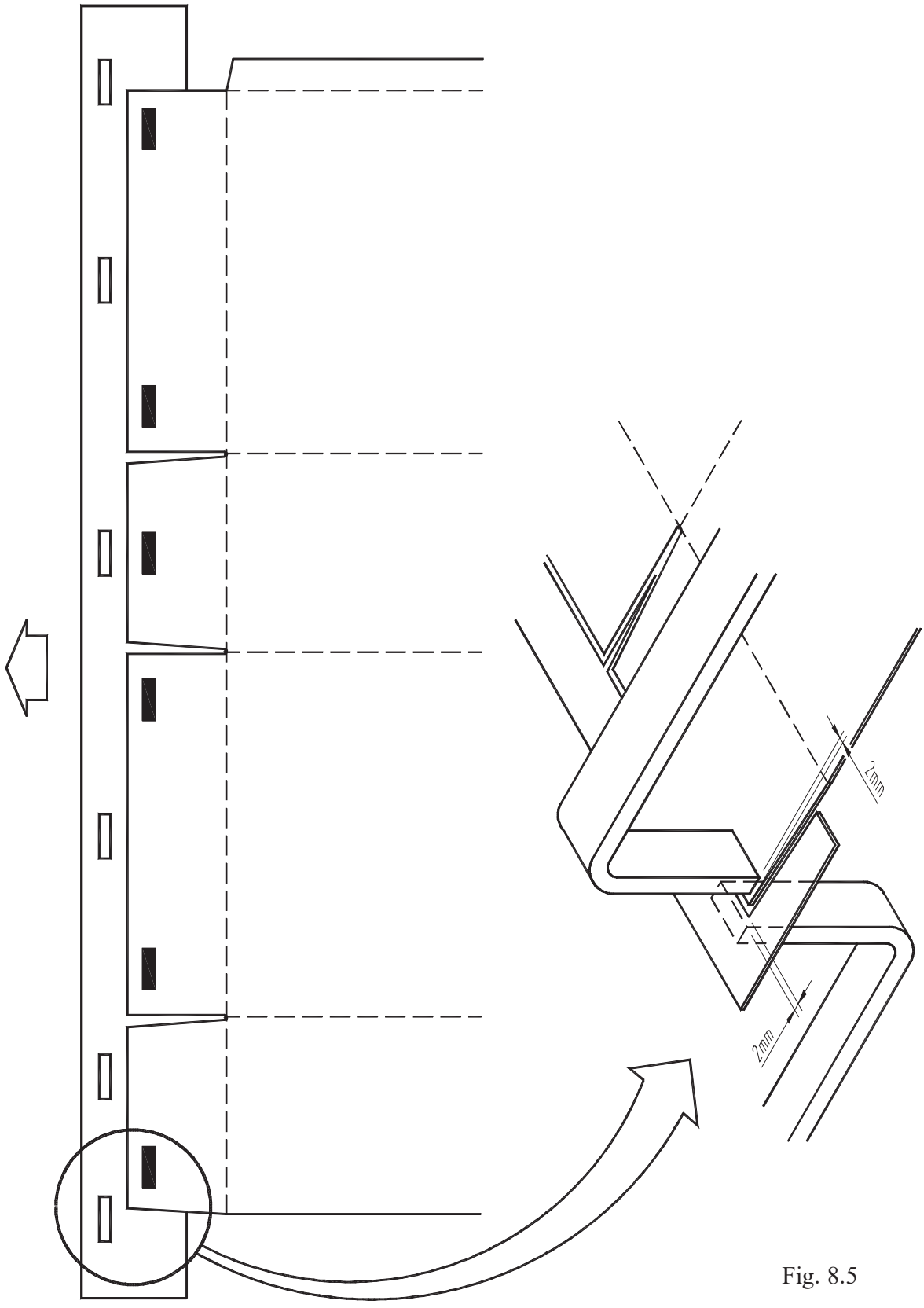

Fig. 8.5

8. DELIVERY

8.1 Description

Run a sheet through to the delivery, before the gripper release the sheet, stop the machine. At this time, the sheet tail shall just sit on the sheet tail tongue (fig. 8.4). If the back supporter (fig. 8.4) is not in this position, push the button 61 or 62 (forward and backward) to move the back supporter to this position. Then adjust the side joggers to both side of the sheet. A clearance about 15mm should be left on each side between the sheet edge and the side jogger.

8.2 Front Waste Edge Stripping

Operation

1. Stop the machine at 180° by jogging (LCD screen will display the machine cycle in degree). Switch the selector switch 65 to left position.
2. Dismantle the gripper opener. (fig. 8.3 fig.8.6)
3. Turn the sheet pusher selector switch to broken line side (fig. 8.1) to disengage the sheet pusher.(fig 8.7)
4. Push the lower tool bar on to the lower tool carrier cross bar from the delivery side window. Switch the selector switch 65 to right position to clamp it.(Lower Platen Manufacturing Instruction fig 8.8)
5. Run a die cut sheet to delivery until the tool carrier cross bars are as close as possible to the sheet. To make sure the lower tool top should be 1-2mm away from the first knife cut. (fig. 8.5)
6. Detach the blanks from the front waste manually. The front waste is still held by the grippers.
7. Switch the selector switch 64 to left position.
8. Push the upper tool bar on to the upper tool carrier cross bar (fig. 8.1-fig. 8.3) from the side delivery window.
9. Switch the selector switch 64 to right position to lock the tool.
10. To adjust the upper tool position to make sure the top is 1-2mm away from the first knife cut.
Remark: If the front stripping die is used, same procedure, but no adjustment mentioned in 10 is needed.
11. Switch the selector switch 63 to the right to engage the front edge waste gripper opener.

8.3 Pre-selection Counter

Set the number of sheets per batch on counter 73. Push the button underneath the dial to operate the counter.



Gripper opener carrier bar



Sheet pusher on the upper tool

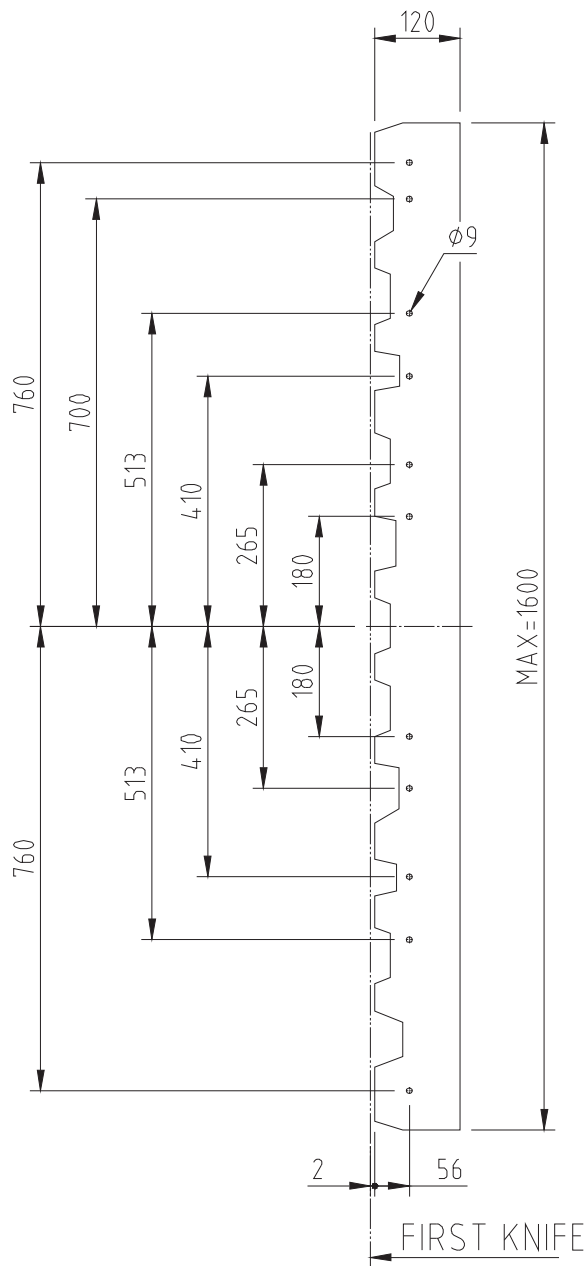

LEAD EDGE STRIPPER HAMMER DIE MOLD
THICKNESS=18mm

Fig. 8.8

8.4 The conveying roller in delivery

The conveying roller in delivery is a selective accessory ,Customers should pay attention to Safety to prevent person from injuring himself due to improper operation .

ETERNA





INSTRUCTIONS
PE1620SA-Extra



Chapter 9

MAKE-READY AND SET-UP



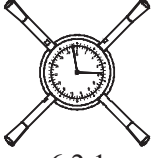

9 MAKE-READY AND SET-UP

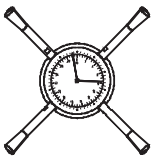
Step-by-step proceeding for set-up a job

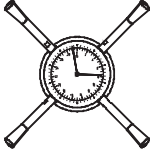
Step No.	LOCATION	OPERATION	See under
1.	DIECUTTER	Remove the cutting die of previous job.	
2.	STRIPPER	Remove the stripping tools or stripping die of the previous job, remaining the female stripping board in the machine so that the new job sheets can pass without problem during the adjustments.	
3.	DELIVERY	<p>Diecut without front edge waste stripping:</p> <ol style="list-style-type: none"> 1. Unlock the upper front edge waste stripping tool by turning selector switch 64 to left. Pull out the tool. Turn the selector switch to right to lock the carrier. 2. Unlock the lower front edge waste stripping tool by turning selector switch 65 to left. Pull out the tool. Insert the gripper opener, and position it right. Turn the selector switch to right to lock the holder. 3. Turn sheet pusher switch 62 to real line. 4. Disengage the front edge waste gripper opener by turning the selector switch 63 to right position. <p>Diecut without gripper margin: Identical with above procedure. Several grippers may need to be removed according to the cutting pattern.</p>	 <p>64</p>  <p>65</p>  <p>62</p>  <p>63</p>
4.	DIECUTTER	<p>Fit the new die into the chase, fasten the die with safety screws.</p> <p>Balance with a compensating die if necessary.</p>	6.5
5.	DIECUTTER	Place the make-ready sheet and glue it to the back of the make-ready plate in register with the cutting rules.	6.7
6.	DIECUTTER	Reduce the cutting force by turning the force control handwheel counter-clockwise for 2 cycles. Normally, by turning 2 cycles, the platen will move downward by 0.2mm.(0.1mm/cycle)	 <p>6.2.1</p>

Step No.	LOCATION	OPERATION	See under
7.	DIECUTTER	Insert the chase into the machine. Depress push button 20 to lock the chase. Tighten the safety lock.	6.6.1
8.	DIECUTTER	If necessary, prepare the counterpart in accordance with the system adopted, channel or pressboard.	6.8.3
9.	FEEDER	Adjust the gripper margin to 15 mm (dial on 15).	 5.2.9
10.	FEEDER	Adjust the side guides by depressing push button 33 or 34 or 35.	 5.2.1
11.	FEEDER	Adjust the position of the rear supporter.	5.2.2
12.	FEEDER	Adjust the height of the front guide hook by depressing the push button 31 or 32. (Subject to the warpsness of the sheet)	 5.2.4
13.	DIECUTTER	Increase the cutting force by turning the force control handwheel clockwise for 1 cycle. The platen will move upward by 0.1mm (0.1mm/cycle). Carry out a cutting test. Check the front and side register.	
14.	FEEDER	If necessary, correct register -lengthwise by adjusting the front lay. -crosswise by shifting the side guides.	

Step No.	LOCATION	OPERATION	See under
15.	DIECUTTER	<p>Increase the force until 80%-90% of the pattern is cut through correctly.</p> <p>Operate the machine without sheets for 3 to 5 minutes so that the rules take up position. Pull the die chase out, and do make-ready.</p> <p>Feed another sheet, check and do make-ready again, if necessary. Then push the die chase back.</p>	 <p>6.7</p>
16.	STRIPPER	<p>Dismantle the female board of the previous job, fit the new one. Feed a sheet into the machine, jog it to the stripper. Adjust the position of the board in relation to the sheet. Tighten all the straps. (If Cobra International Centerline System is used, no adjustment for the position of female board is needed.)</p>	7.3.4
17.	STRIPPER	<p>Fit the upper tools of either type:</p> <ul style="list-style-type: none"> -quick-lock tools -stripping die(If Cobra International Centerline system is adopted.) 	7.1
18.	DELIVERY	<p>Run a sheet through to the delivery. Adjust the position of the back supporter by depressing the button 61 or 62. Then adjust the side joggers to both side of the sheet.</p>	8.1

Step No.	LOCATION	OPERATION	See under
19.	DELIVERY	<p>Diecut with front edge waste stripping:</p> <ol style="list-style-type: none"> 1. Turn the selector switch 64 to left. Insert the upper front edge waste stripping tool bar. Turn the selector switch to right to clamp the tool in the carrier. 2. Turn the selector switch 65 to left. Pull out the gripper opener. Insert the lower front edge waste stripping tool bar. Turn the selector switch to right to clamp the tool in the holder. 3. Turn sheet pusher switch 62 to broken line. 4. Turn the selector switch 63 to the right to engage the front edge waste gripper opener. 5. Turn on the front edge waste conveyor on the top of the machine. 	 64  65  62  63 8.2
20.	CONTROL DESK	Set the number of sheets per batch on the counter.	8.3
21.		Jog feed a few sheets, watch the feeding, cutting ,stripping, front edge waste stripping and delivery. Correct if necessary.	
22.		Start up the machine for continuous run. Check the first die cut sheet, and do fine make ready if necessary.	
23.		<p>If machine runs properly, start production by depressing push button 44. Machine will speed up automatically to the speed set on potentiometer 43. If speed needs to be reset, turn the potentiometer 43 to the position which represents the speed desired. Depress push button 46 to start speed acceleration or deceleration.</p> <p>Depress the push button 46 again, machine speed will decrease to crawling speed. Depress again, speed will be back to the desired speed.</p>	

ETERNA

INSTRUCTIONS
PE1620SA-Extra

Chapter 10

LCD Touch Screen

Screen 2

Turn the key switch on the main operation panel of the host machine to ON, and the touch screen shall display ETERNA logo, then enter Screen 1 automatically.



Screen 1

Display the visual appearance of the machine. Press the lower line below to enter Screen 16. press the upper line to enter Screen 7.

Enter Screen 2

Welcome to use PE1620 Flatbed Automatic Die cutter

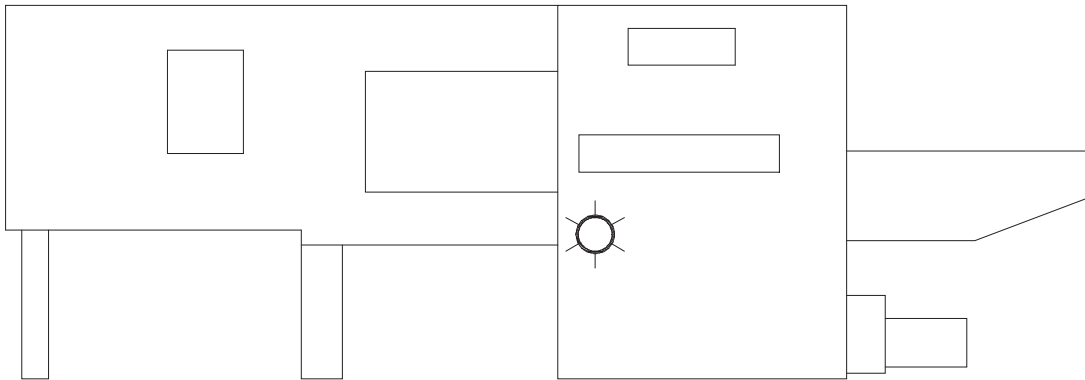

ETERNA Shanghai Eterna Precision Machinery Manufacture Co. Ltd

Enter Screen 3

Screen 3

Address and contact of the manufacturer or dealer.



**Shanghai Eterna Precision Machinery
Manufacture Co. Ltd.**

Factory Address:

**1125 Taishun Road, Anting Town, Jiading
District, Shanghai 201814**

Tel : (021) 5 9 5 0 2 4 5 1

Fax : (021) 5 9 5 0 2 4 9 0

Return

Product

Screen 2

This is the Main Menu screen, including 8 main functions:

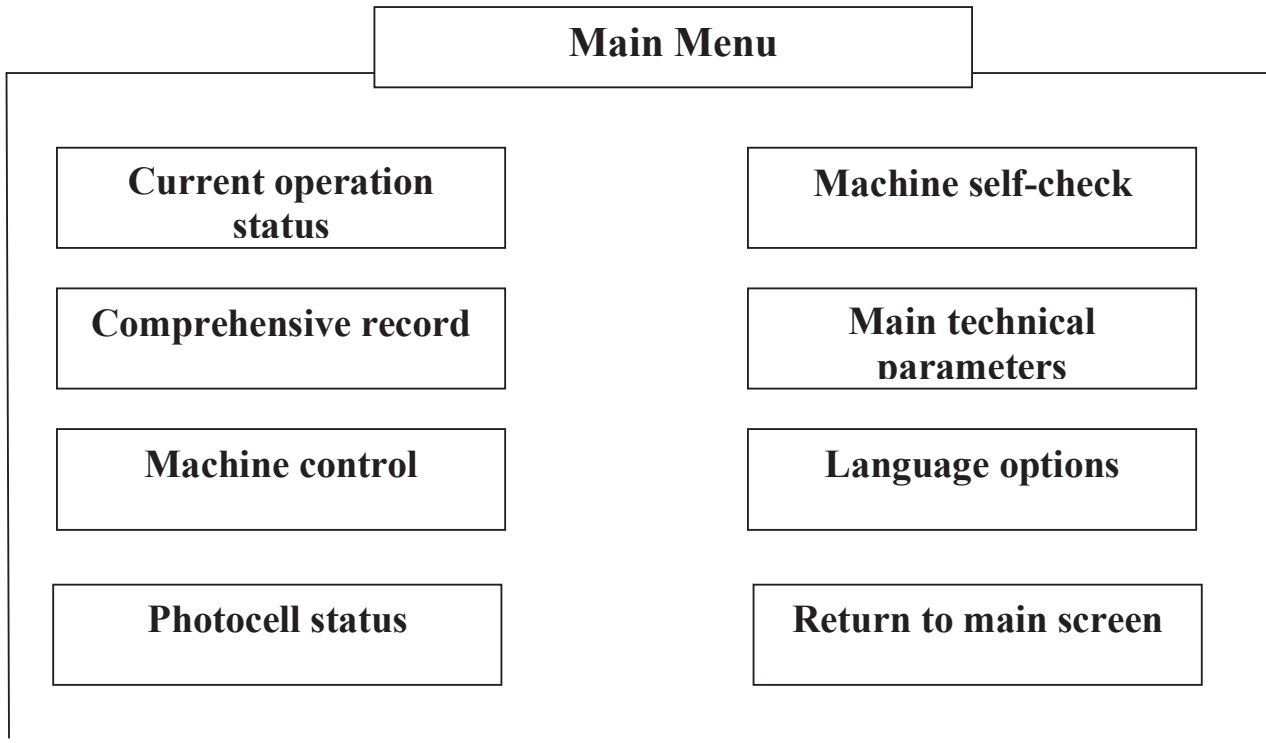

Current operation status	Enter Screen 10, to display operation speed and angle of machine
--------------------------	--

Machine self-check	Enter Screen 25, to display self-check of all machine parts
--------------------	---

Comprehensive record	Enter Screen 70, to display machine operation records, e.g. total operation sheets, work records, etc.
----------------------	--

Main technical parameters	Enter Screen 50, to display main technical parameters
---------------------------	---

Machine control	Enter Screen 40, to display short cylinder delay adjustment, side support control, side support time adjustment, delivering and air blow.
-----------------	---

Language options Enter Screen 60, to display 2 choices of language

Photocell status Return to Screen 30, to display all the photocell status of the machine

Return to main
screen Return to Screen 1

Screen 25

Working condition and abnormal condition of all parts of the machine.

Machine Self-check		Return to main	
Main motor	Alarm	Feeding section	Error
Lubricating pump	Alarm	Diecutting	Error
Main clutch	Not closed	Stripping	Error
Machine operation	Emergency stop	Delivering	Error
Gripping bar test	Abnormal	PLC	Error
Photo cell	Not used	Safety door	Not closed

Screen 209

Photocell test of the stripping section.

Error of Stripping Section – Detection

Photo cell test of Stripping Section

Normal

**If the photocell test of the stripping section
is abnormal, check and clean the stripping section.**

**Return to
main screen**

**Return to
machine self-
check screen**

Screen 202

Oil pressure detection.

Oil line alarm/insufficient oil pressure—Possible Cause		
1. Air switch NFB6 not closed or stripping.		
2. Oil pump motor M3 overloaded or operating lack phase.		
3. Clogging of oil filter screen and oil line or low level of oil tank.		
4.		
Note: When the oil pressure is not sufficient, do not start the machine in any way ! ! !		
Return to main screen	Oil pressure detection	Abnormal
Return to machine self-check screen	Air switch	Close
	Oil pump motor	Overload

Screen 203

Air pressure detection.

Failure of Host Machine Clutch —Possible Cause	
1. Air compressor not start;	
2. Clogging of air line, water ingress or leakage;	
3. Air pressure microswitch not adjusted properly;	
Note: Air pressure must be more than 5KG/CM²(70PSI) °	
Air pressure test	Normal
Return to main screen	Return to machine self-check screen

Screen 204

Various causes resulting in emergency stop.

Emergency Stop -Possible Cause

1. **Emergency Stop button was pressed.**
2. **Power supply of key switch was closed.**
3. **Barring option switch was turned to barring position.**
4. **Barring protection handle not reset.**

**Return to
main screen**

**Return to
machine self-
check screen**

Screen 212

Safety door detection of all parts of the machine.

Details of Safety Door Status	
Safety door of feeding section	Closed
Safety door of diecutting section	Closed
Safety door of gripping operation surface	Closed•
Safety door under stripping drive face	Closed•
Safety door above drive face of stripping section	Closed•
Large safety door at delivery	Closed•
Small widow at delivery	Closed•
Return to main screen	Return to machine self-check screen

Screen 206

Whether the Photo Cell Detection is on.

Photo Cell Not in Use—Possible Cause

**“Photo Cell Detection” option switch not
turned to “On” position**

**Return to
machine
self-check**

**Return to
main screen**

Screen 201

Main motor detection

Main Motor Alarm—Possible Cause		
<ol style="list-style-type: none">1. Lack phase, undervoltage or overvoltage of power supply line.2. Air switch NFB2 not closed.3. Main motor M1 operating overload or lack phase.4. Alarm of converter or braking unit.		
	Self-check	
Return to main screen	Air switch	Closed
Return to machine self-check	Converter	Normal
	Braking Unit	Overheated

Screen 205

Detection of torque clutch and gripping bar.

Failure of Host Machine Clutch—Possible Cause	
1. Air compressor not started.	
2. Clogging, water ingress or leakage of gas line.	
3. Air pressure microswitch not adjusted properly.	
Note: Air pressure must exceed 5KG/CM²(70PSI).	
Self-check of Torque Clutch	Unhitch
Return to main screen	Return to machine self-check screen

Screen 207

Detection of feeder section

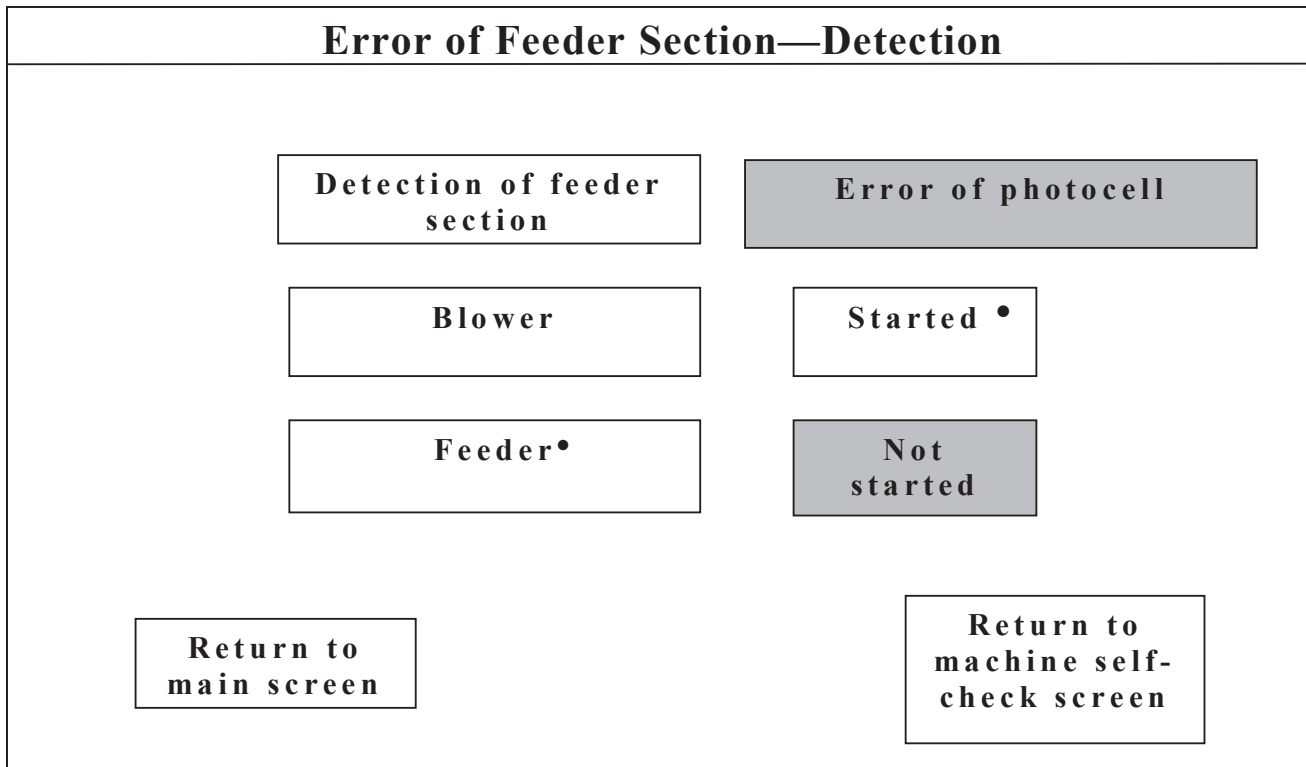

Screen 208

Detection of diecutting section

Error of Diecutting Section—Detection		Return
Detection of chase infeed side locking	L o c k e d	
Detection of chase center locking	L o c k e d	
Detection of chase discharge side locking	L o c k e d	
Detection of diecutting steel plate locking	L o c k e d	
Diecutting discharge	L o c k e d	
Pressurized discharge	L o c k e d	

Screen 210

Detection of delivering section

Error of Delivering Section—Detection	
Disorder sheets detection photocell	Normal
Jogging detection photocell	Normal
Delivering table	Normal
Photocell for cylinder safe extracting	Normal
Return to main screen	Return to machine self-check screen
Next Page	

Screen 50

Main technical parameter of machine

Main Technical Parameters (1)	
Max. sheet size	<input type="text" value="....."/>
Min. sheet size	<input type="text" value="....."/>
Applicable sheet width	<input type="text" value="....."/>
Max. diecutting size	<input type="text" value="....."/>
Chase inner guide size	<input type="text" value="....."/>
Diecutting steel plate size	<input type="text" value="....."/>
<input type="button" value="Return to main screen"/>	<input type="button" value="Next Page"/>

Screen 51

Main technical parameters

Main Technical Parameters (2)	
Max. diecutting force	••••tons•
Min. margin width	•••••
Standard cutting die height	••••••••
Max. machine speed	•••••sheets/h•
Power supply	••••••••••••••••••
Entire machine weight	32 tons
Return to main screen	Return to previous page

Screen 211

PLC self-check

PLC Error—Possible Cause

1. Wire connection loosened.
2. Cable plug not properly connected.
3. Exhaust of batteries in PLC.

Cell detection •

Exhausted •

Return to
main screen

Return to
machine self-
check screen

Screen 71

Comprehensive records of machine

Comprehensive Records	
Total machine operation time	Hours
Total diecutting table operation times	Times
Total quantity of diecutting	Sheets
Current work records		Return to main screen

Total machine operation time	Display the total operation time accumulated from the 1 st day.
Total diecutting table operation times	Display the total diecutting table operation times accumulated from the 1 st day.
Total quantity of diecutting	Display the total diecutting quantity accumulated from the 1 st day.

Screen 70

Current work status. Press “Zero Current Work Record”, and enter Screen 73 to clear the current work records.

Current Work Record			
Estimated diecutting sheets.	
Time	Hours
Total diecutting sheets		Sheets
Return to main screen	Zero current work records	Comprehensiv e records	

Screen 73

In Screen 70 (Current Work Record) , press "Zero Current Work Record", to enter this Screen ◦

Press "Confirm" to erase current work records.

Press "Abandon" to return to the previous screen.

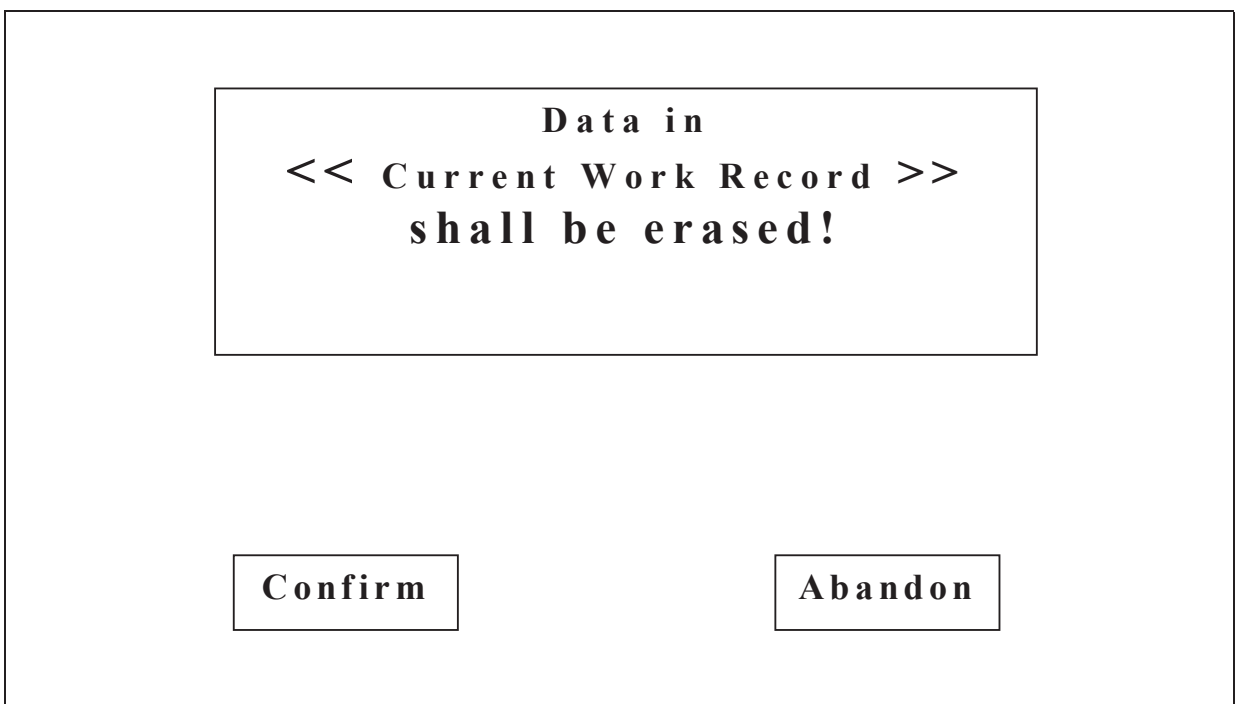

The screenshot displays a confirmation screen with a central message box and two buttons at the bottom.

**Data in
<< Current Work Record >>
shall be erased!**

Confirm **Abandon**

Screen 10

Operation speed of machine

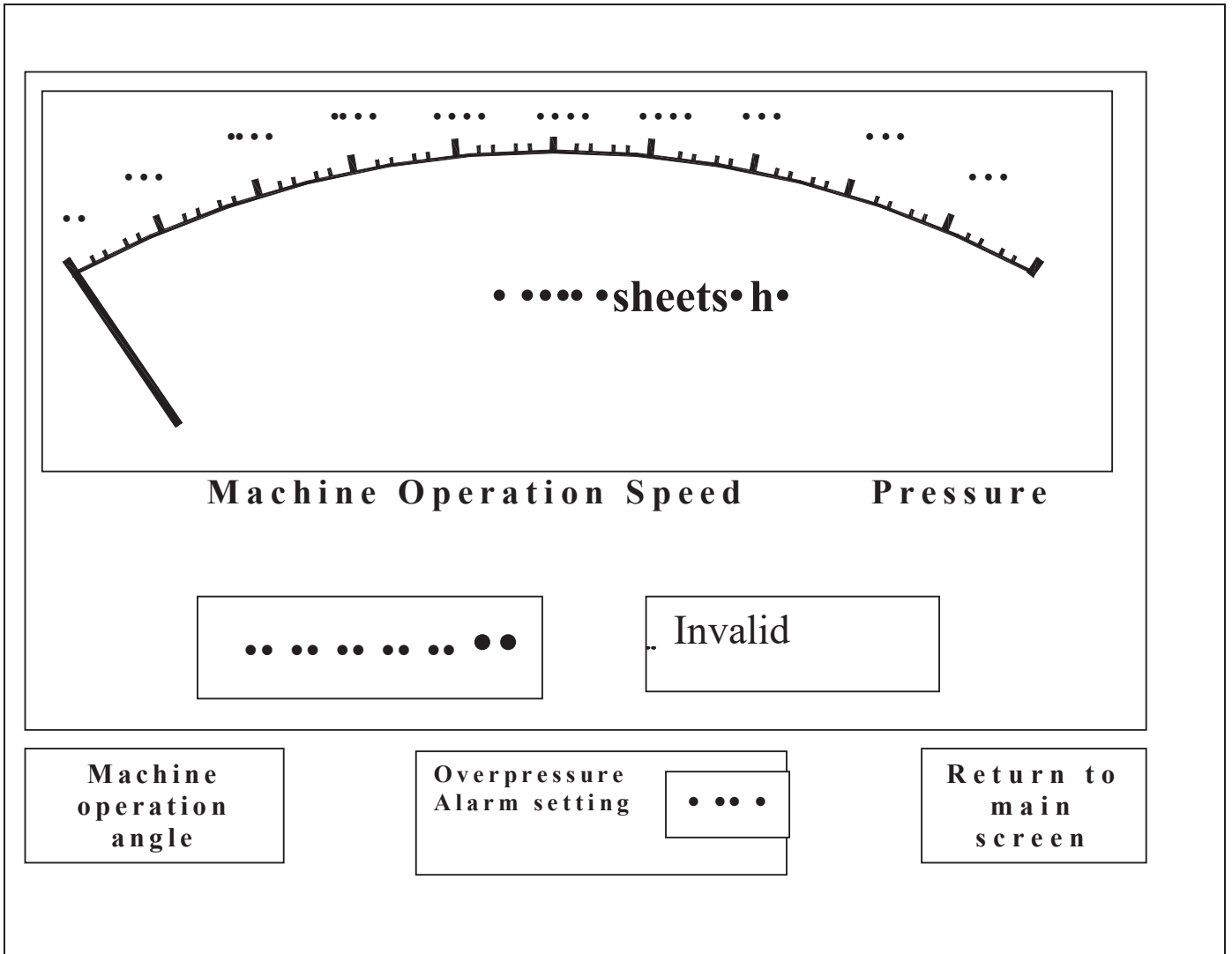

Screen 11

Machine operation angle. It shall be used when setting the machine detection angle.

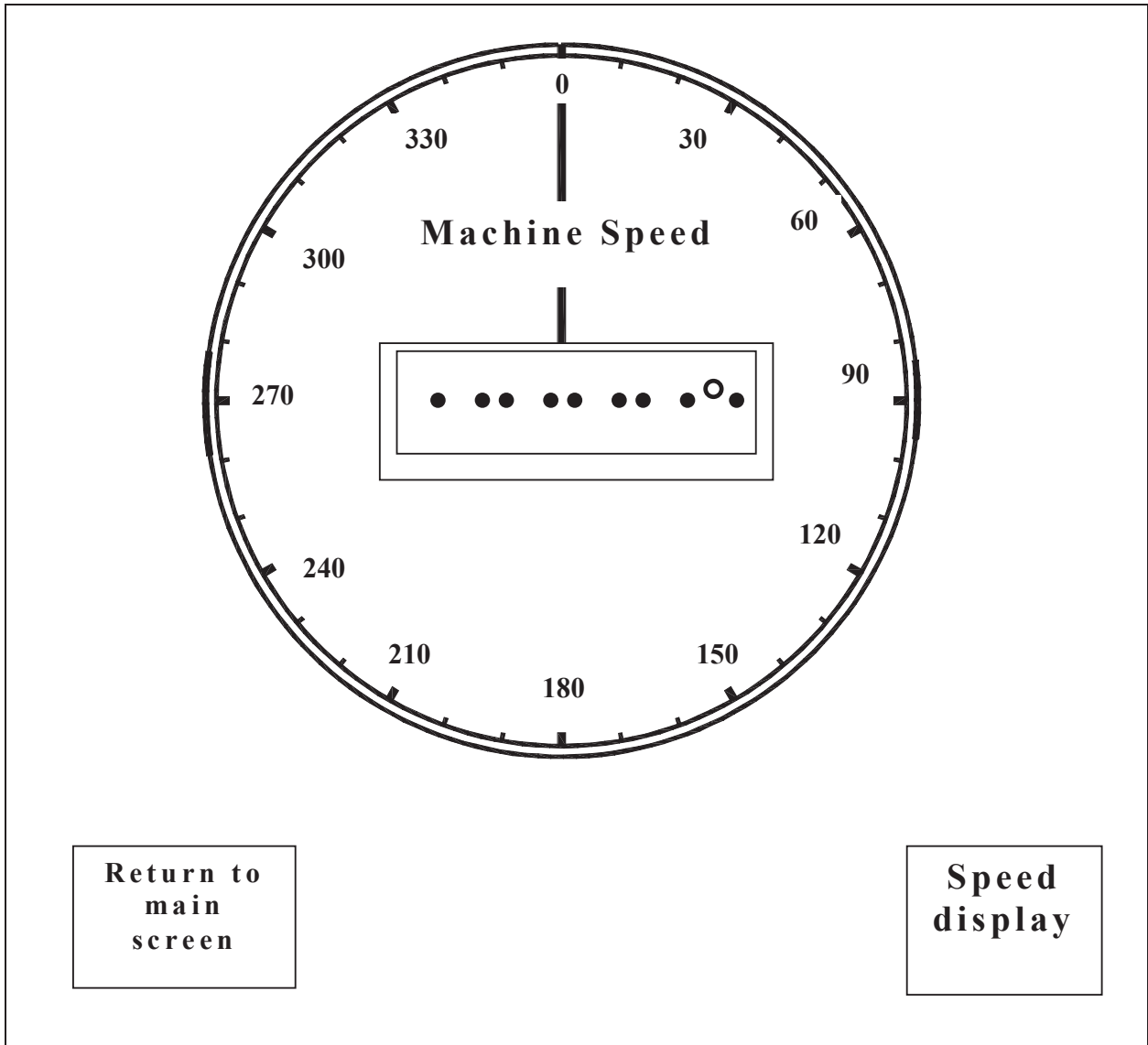

Screen 14

The Screen for setting the machine detection angle, used for the machine maintenance personnel.

Test Item	Initial Angle	Final Angle
Gripping bar detection	<input type="text" value="....."/> <input type="text"/>	<input type="text" value="....."/> <input type="text"/>
Feeder side beat signal	<input type="text" value="....."/> <input type="text"/>	<input type="text" value="....."/> <input type="text"/>
Feed surpassing	<input type="text" value="....."/> <input type="text"/>	<input type="text" value="....."/> <input type="text"/>
Detection of sheet front gauge in place	<input type="text" value="....."/> <input type="text"/>	<input type="text" value="....."/> <input type="text"/>
Machine operation angle screen	Change Password <input type="text" value="....."/> <input type="text"/>	Next page

- | | |
|---|--|
| <input type="text" value="Gripping bar detection"/> | To set the detection time of the gripping bar. |
| <input type="text" value="Feeder side beat signal"/> | To set the time of feeder side beat action. |
| <input type="text" value="Feed surpassing"/> | To set the time for detection of sheet surpassing. |
| <input type="text" value="Sheet front lay in place"/> | To set the time for detection of sheet front lay |

Screen 15

For setting the machine detection angle, only for the use of the machine maintenance personnel.

Test Item	Initial Angle	Final Angle
Detection of infeed sheet drop	<input type="text" value="....."/>	<input type="text" value="....."/>
Detection of sheet length	<input type="text" value="....."/>	<input type="text" value="....."/>
Detection of diecutting outlet empty feed	<input type="text" value="....."/>	<input type="text" value="....."/>
Detection of diecutting outlet skew sheet	<input type="text" value="....."/>	<input type="text" value="....."/>
Machine operation angle screen	Last page	Next page

Detection of infeed sheet drop

To set the time for detection of infeed sheet drop.

Detection of sheet length

To set the start/end time for detection of sheet length.

Detection of diecutting outlet empty feed

To set the time for detection of empty feed at the diecutting discharge outlet.

Detection of diecutting outlet skew sheet

To set the time for detection of skew sheet at the diecutting outlet.

Screen 16

For setting the machine detection angle, only for the use of the machine maintenance personnel.

Test Item	Initial Angle	Final Angle
Chase withdrawing time•	<input type="text" value="....."/>	<input type="text" value="....."/>
Detection of stripping outlet empty feed•	<input type="text" value="....."/>	<input type="text" value="....."/>
Detection of stripping outlet skew sheet•	<input type="text" value="....."/>	<input type="text" value="....."/>
Detection of delivering disordered sheet•	<input type="text" value="....."/>	<input type="text" value="....."/>
Machine operation angle screen	Last page	Next page

Chase withdrawing time	To set the time to pull out the chase.
Detection of stripping outlet empty feed	To set the time for detection of empty feed at the stripping discharge outlet.
Detection of stripping outlet skew sheet	To set the time for detection of skew sheet at the stripping discharge outlet.
Detection of delivering disordered sheet	To set the time for detection of the disordered sheet at the delivering section.

Screen 17

For setting the machine detection angle, only for the use of the machine maintenance personnel.

Test Item	Initial Angle	Final Angle
Delivering table drop signal	<input type="text" value="....."/> <input type="text"/>	<input type="text" value="....."/> <input type="text"/>
Delivering section jogging	<input type="text" value="....."/> <input type="text"/>	<input type="text" value="....."/> <input type="text"/>
Feeding section butterfly valve 13#	<input type="text" value="....."/> <input type="text"/>	<input type="text" value="....."/> <input type="text"/>
Machine operation angle screen	Previous page	Next page

Delivering table drop signal	To set the time for detection of start/end signal of delivering table drop.
Delivering jogging	To set the time of jogging of the delivering section.
Feeding section butterfly valve 13 #	To set the starting time of delivering section exhaust valve.

Screen 18

For setting the machine detection angle, only for the use of the machine maintenance personnel.

Test Item	Initial Angle	Final Angle
Feeder air valve14 # <input type="text"/> <input type="text"/>
Feeder stop valve15 # <input type="text"/> <input type="text"/>
Conveyor side sheet support signal <input type="text"/> <input type="text"/>
Delivery count sheet interval signal <input type="text"/> <input type="text"/>
Machine operation angle screen	Previous page	Next page

To set the action time of the feeding section air blow valve.

To set the action time of the small feed pallet.

To set the time for detection the delivery side sheet support action.

To set the start/end time of sheet interval count.

Screen 19

For setting the machine detection angle, only for the use of the machine maintenance personnel.

Test item	Initial Angle	Final Angle
Delivering air blow signal	<input type="text" value="....."/>	<input type="text" value="....."/>
Machine operation angle screen		Previous page

Delivering air blow signal	To set the time of delivering air blow signal.
----------------------------	--

Screen 12

Press the active table button 12, this screen appears, which means the active table of the machine stops at the lowest point and the diecutting chase can be pulled out.

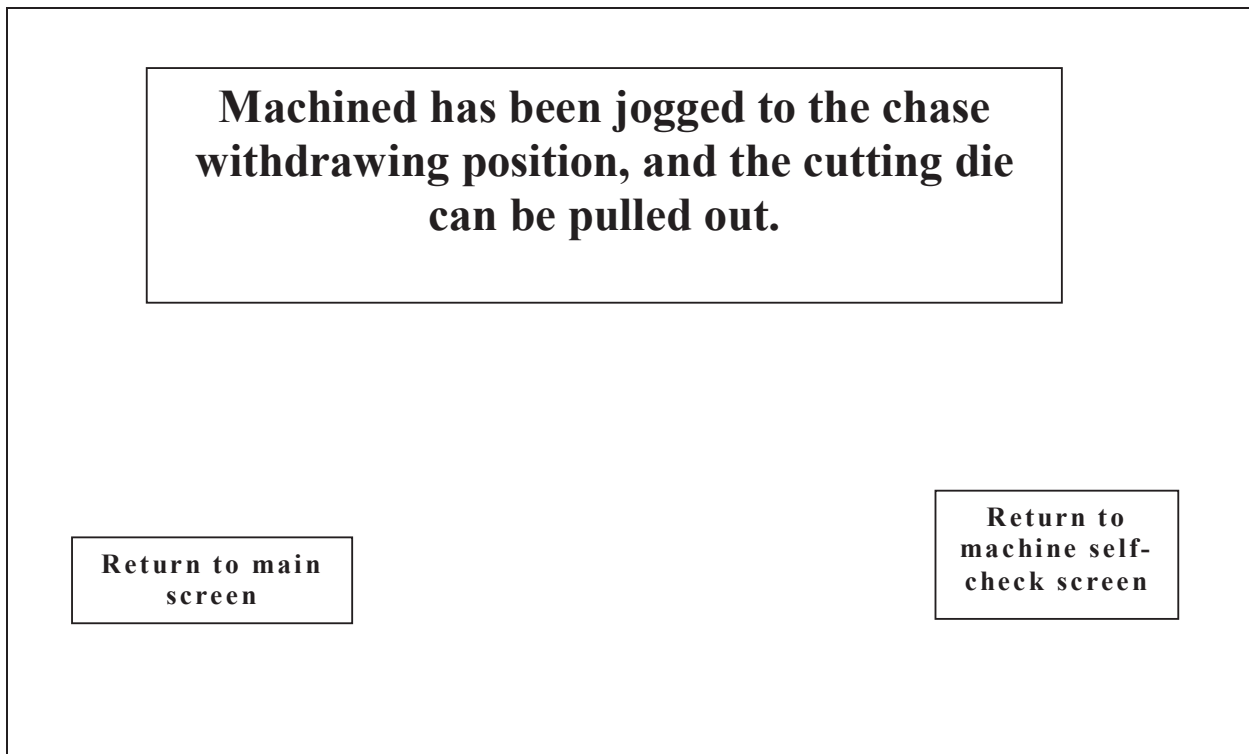

Screen 214

Detection whether the front stripping upper/lower die is locked. Press the jog button 28 or continuous operation button 27, and the upper die or lower die has not been locked, this screen will appear.

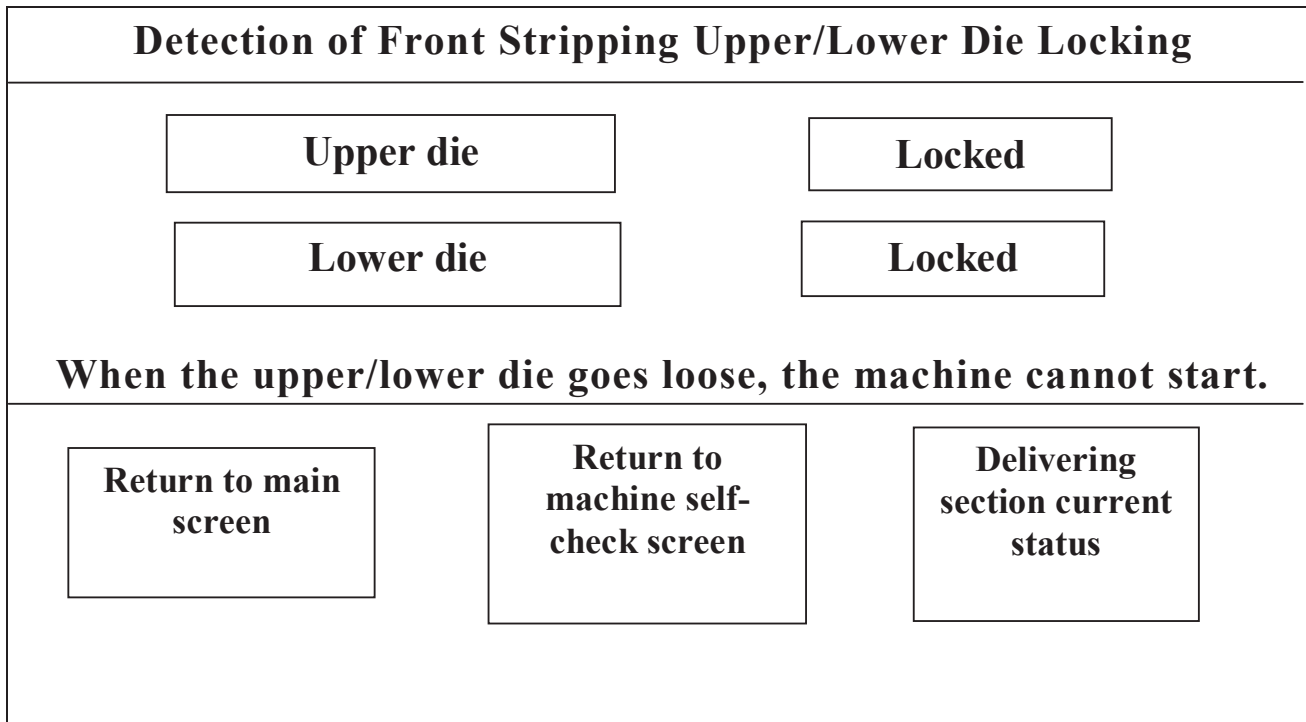

Screen 213

Self-check of the Delivering section

Delivering Section Current Status		
Delivering table status	Stop	
Delivering table position	In limit	
Delivering cylinder•	Extend	
Delivering pile transfer	Auto	
Return to main screen	Return to machine self-check screen	Return to previous page

ETERNA

INSTRUCTIONS
PE1620SA-Extra

Chapter 11

MAINTENANCE AND LUBRICATION

11.MAINTENANCE AND LUBRICATION

11.1 MAINTENANCE AND LUBRICATION ITEMS

1. Gripper bar (including chain and oil nipples on gripper bar) should be lubricated once a month.
2. Recycling automatic lubrication system in diecutting section.

A. Pump:

Once a week, take off the filter to discharge the waste.

B. Lubrication:

Oil pressure gauge should be observed from time to time, it should be kept with proper oil level.

If the oil level is too low for circulation, the toggle system could be overheated by friction. At this time, the oil pressure gauge will show that the oil level is below the warning level, and the machine will stop automatically.

3. Manual Central Lubricating Oil Pump:

To pump the oil pump once a week, by depressing the handle at least three times.

4. Grease Nipple: To grease the nipples once a week

5. Vacuum pump: Please refer to *Air Compressor Instruction*.

Note: To change the oil 3 months after the machine installation. To drain all the oil in reservoir and to refill 25 gallon oil (100l) . After that, to change oil every 3 months. Should the machine run averagely 16 hours each working day, the oil should be changed every 3 months.

6. Oil chart:

International Code	Part	Volume (L)
MOBIL DTE25	Recycling Lubrication System	100
Mobil gear SHC 460	Cam Oil Cup & Index	72
Mobilux EP2	Linear Bearing	1
Mobilux EP023	All the Grease Nipples	1
ISOVG32	Air Pipe	1

11.2 Recycling Automatic Lubrication System

1. Lubrication to Crank Shaft Drive

The crank toggle drive at the die cutting section is the very important part of the machine. All the lubrication spots shown in Fig.11.1 must be oiled for sure. Therefore, the recycling automatic lubrication system is used for this part to guarantee the proper lubrication at the each spots.

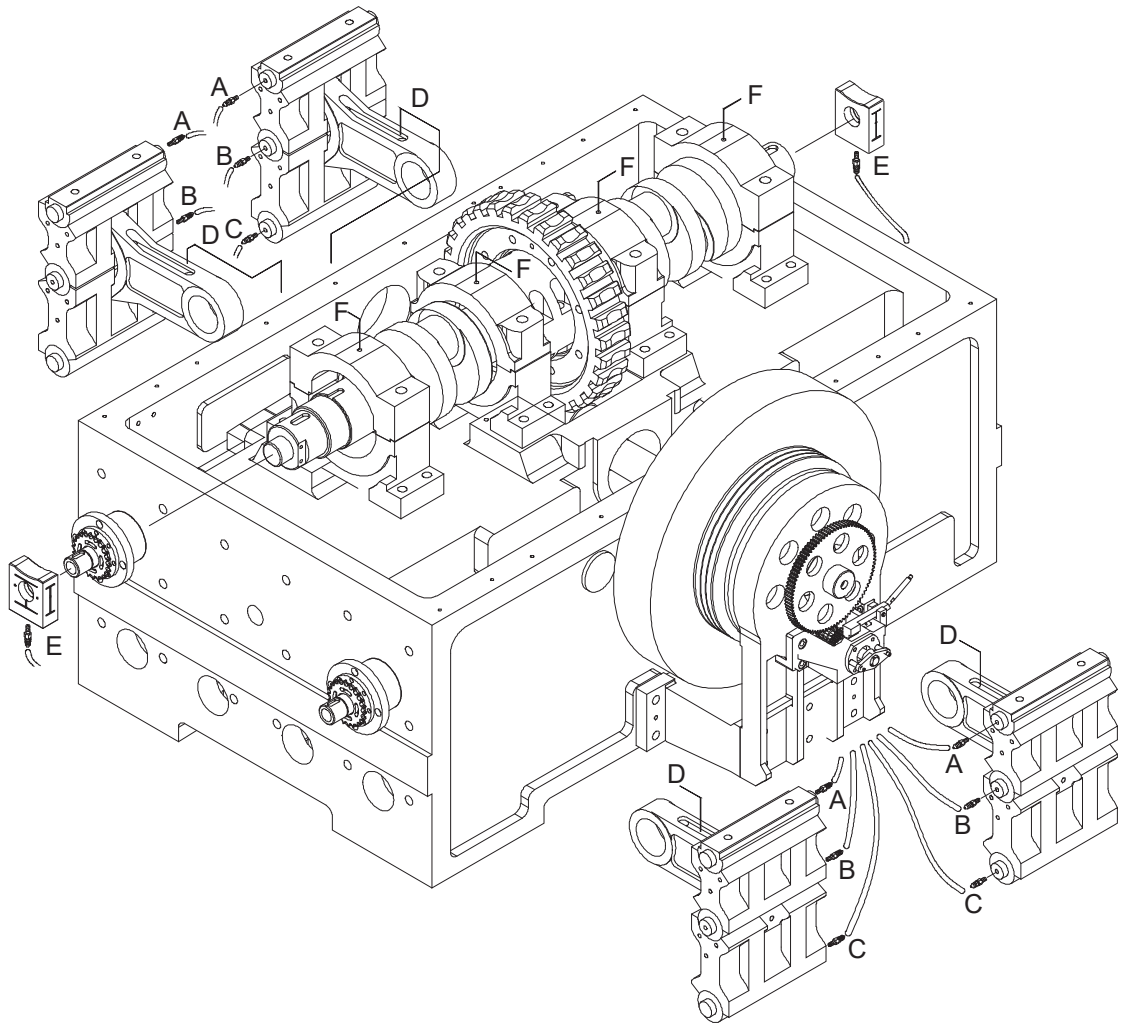

Fig.11.1

A. Toggle Shaft (Upper)
B. Toggle Shaft (Middle)
C. Toggle Shaft (Lower)

D. Connecting Arm
E. Sliding Brass Block
F. Crank Shaft

2. Pump Lubrication System (Fig.11.2)

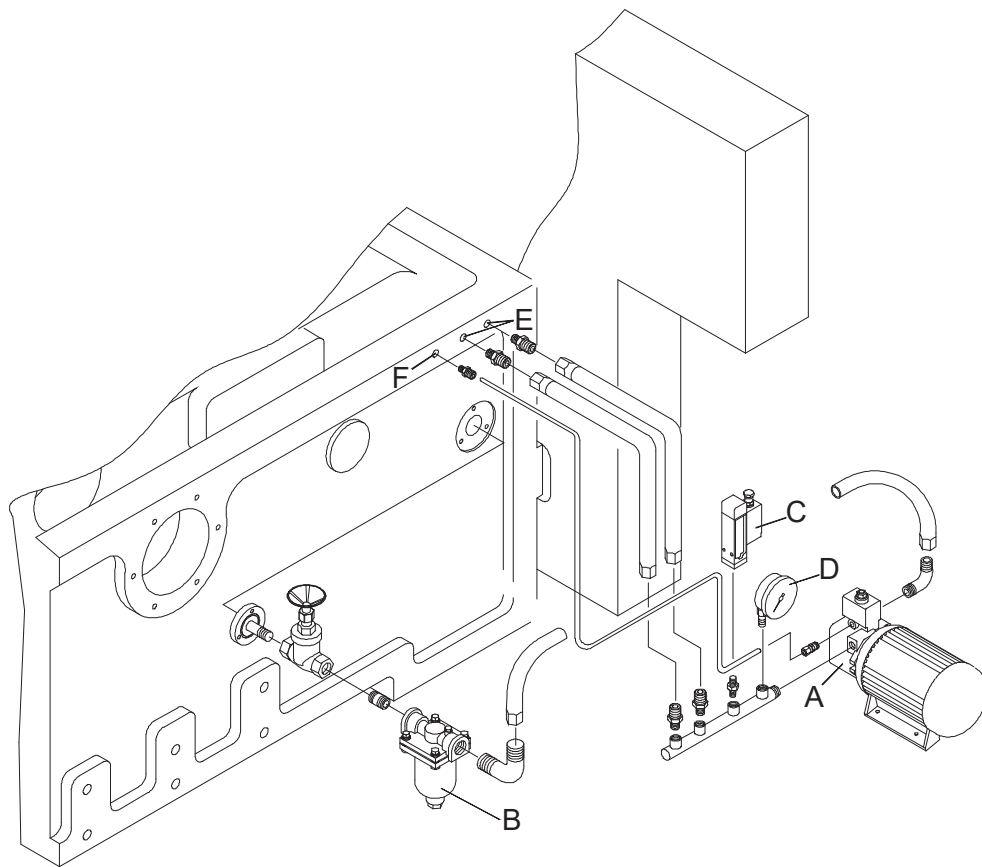

Fig.11.2

A. Oil Pump

B. Filter

C. Pressure Valve

D. Pressure Meter

E. Crank Shaft Drive (Oil Inlet)

F. Oil Outlet

3. Oil Filter (Fig.11.3)

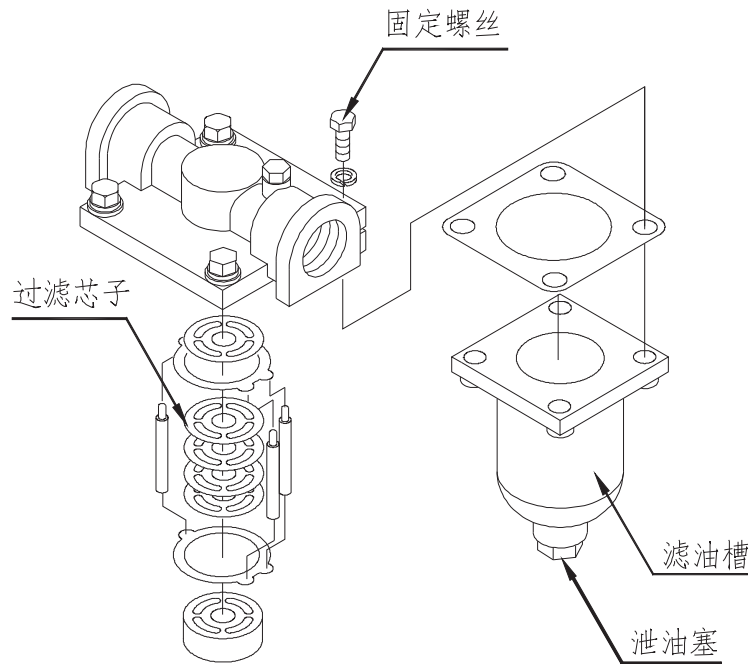

Fig.11.3

- 1.The oil filter at the inlet of pump should be cleaned frequently.
- 2.The filter core should be stripped and cleaned every month.

How to clean filter core:

- Remove four bolts.
- Pull down the cup then take it out.
- Release the plug of the cup, turn the cup up side down, discharge the waste, then clean the cup.
- The filter core should also be cleaned completely (To blow with compressed kerosene air).
- Reassemble it in reversed order.

4. Oil Pressure Gauge

There is an oil pressure gauge on the basement between diecutting section and stripping section. Oil should be kept in proper level, if the oil level is too low for circulation, the toggle system could be overheated by friction. At this time, the indicator will show that the oil level is below the normal level, and the machine will stop automatically. (Normal pressure data: 1.5--2 Kg/cm²)

11.3 CENTRAL LUBRICATION MANUAL PUMP AND GREASE NIPPLES

1. Pump:

The pump should be operated every week, and for each lubrication, the pump should be pressed at least three times.

2. Grease Nipples and Spots to be Greased:

Greasing should be performed once a week.

A. Grease Nipples

B. Self-lubricated Blocks



Figure 1. Front conveyor drive lubrication cream nozzle (symmetrical), filling type: A



Figure 2. Moveable support rack (symmetrical), oil filling type: A

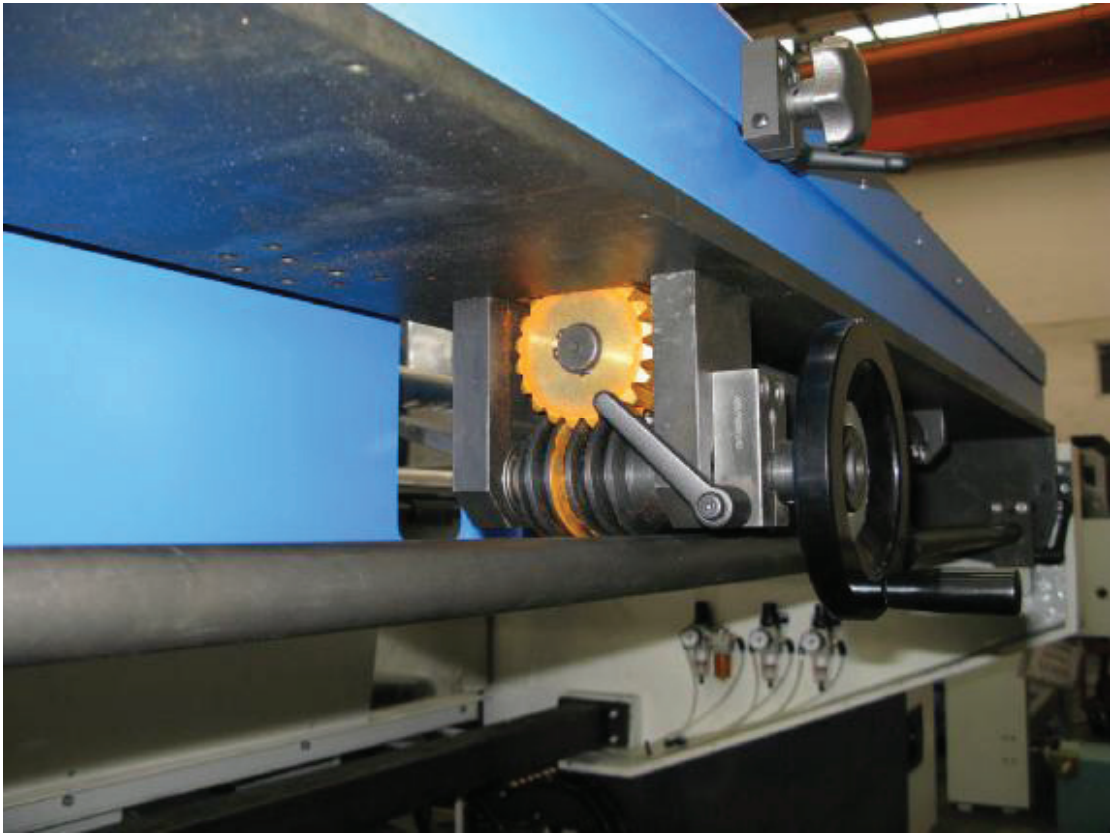

Figure 3 Worm Gear of feeder, oil filling type: A



Figure 4. Side guide screw rod (symmetrical), oil filling type: A

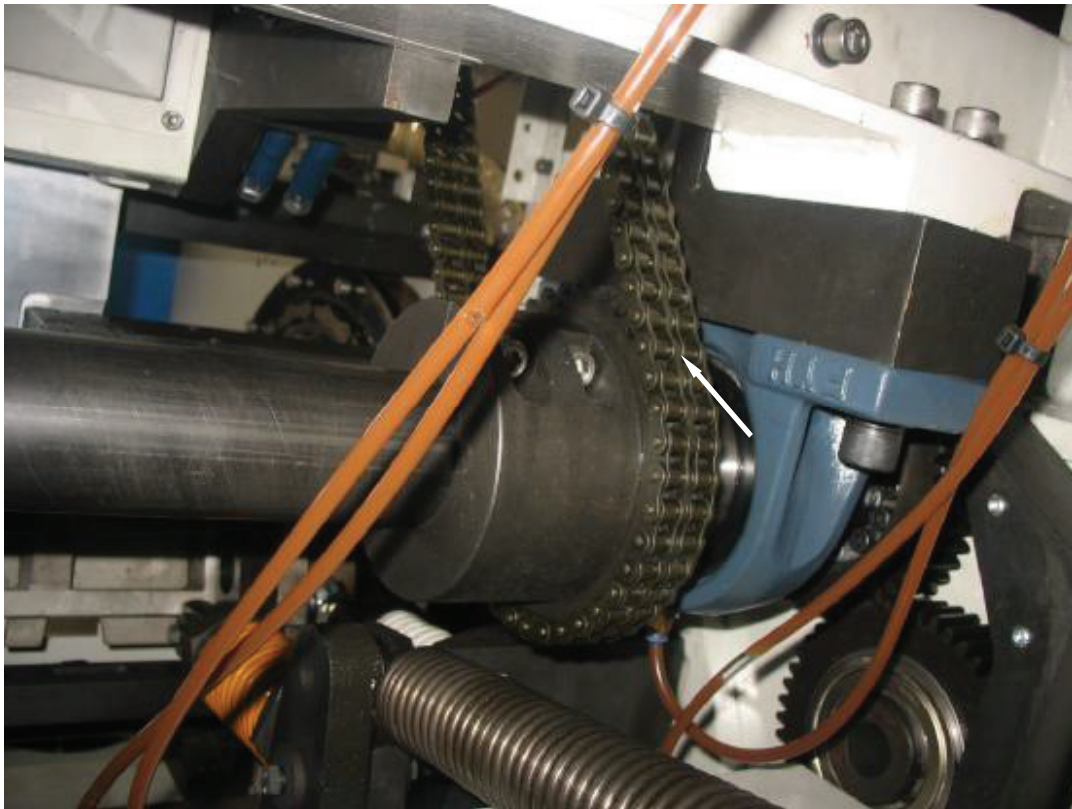

Figure 5. Feeder support cam drive chain, oil filling type: B

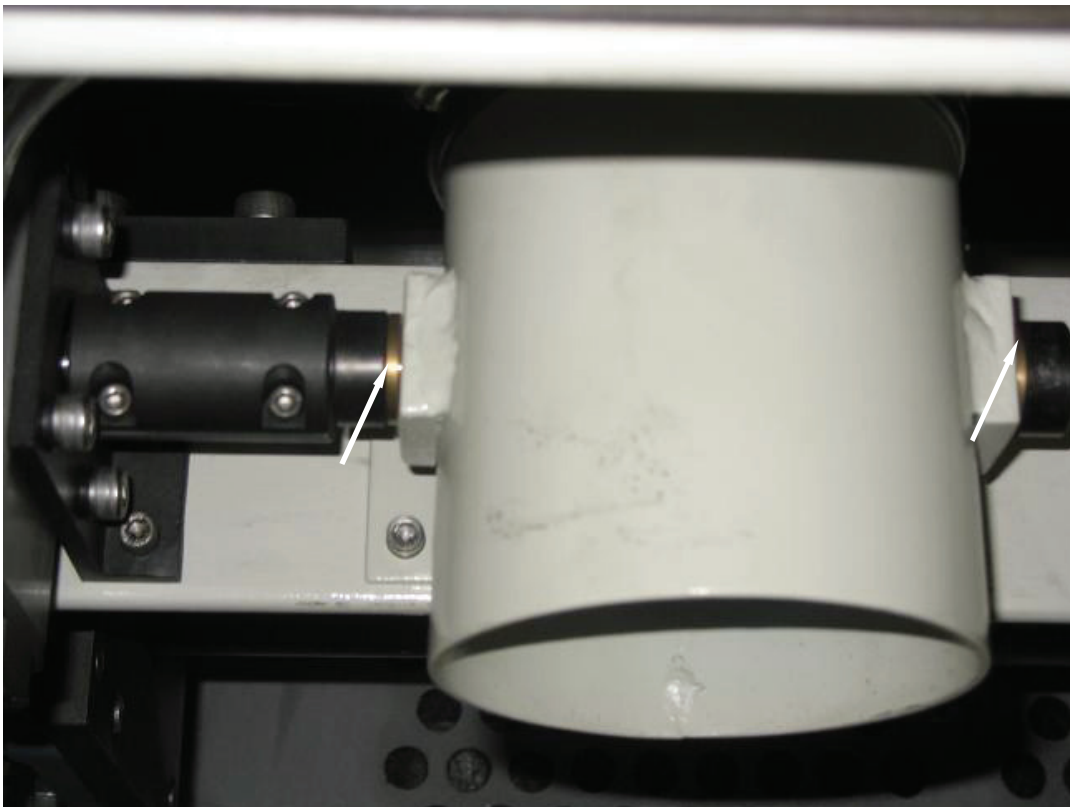

Figure 6. Exhaust outlet brass bushing (symmetrical), oil filling type: B

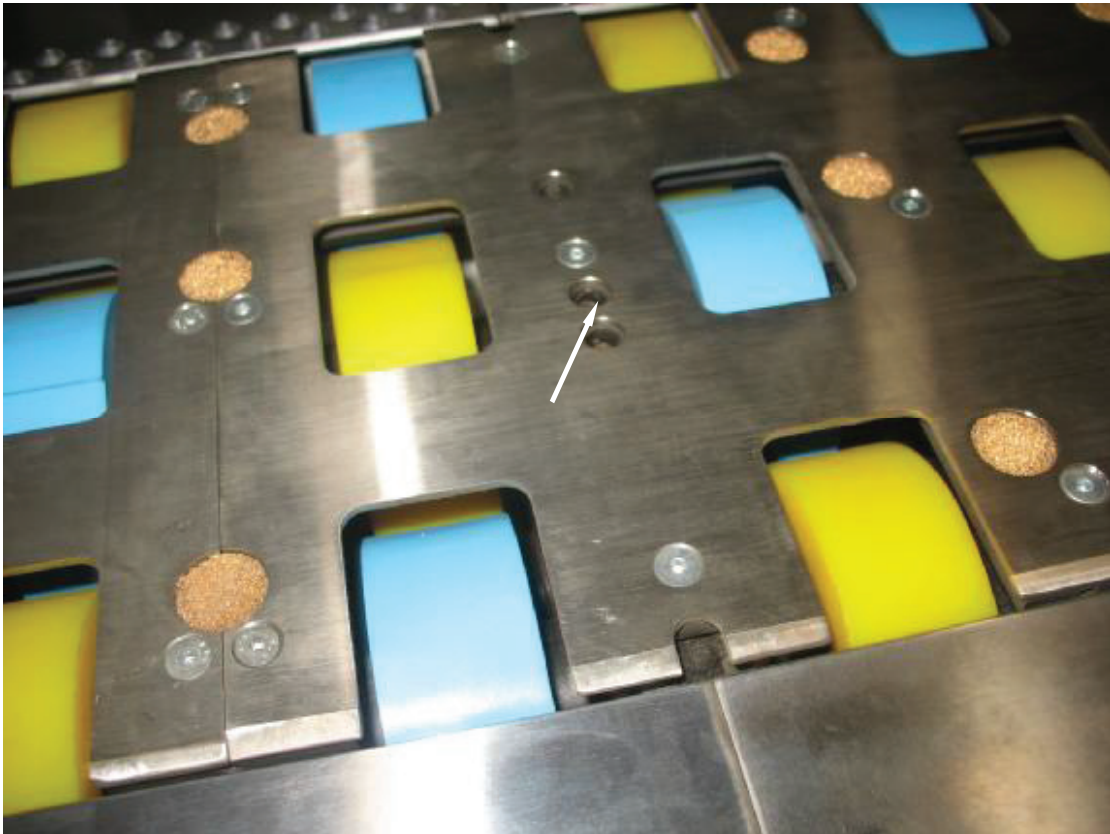

Figure 7. Feeder roll lubrication cream nozzle (symmetrical), filling type: A

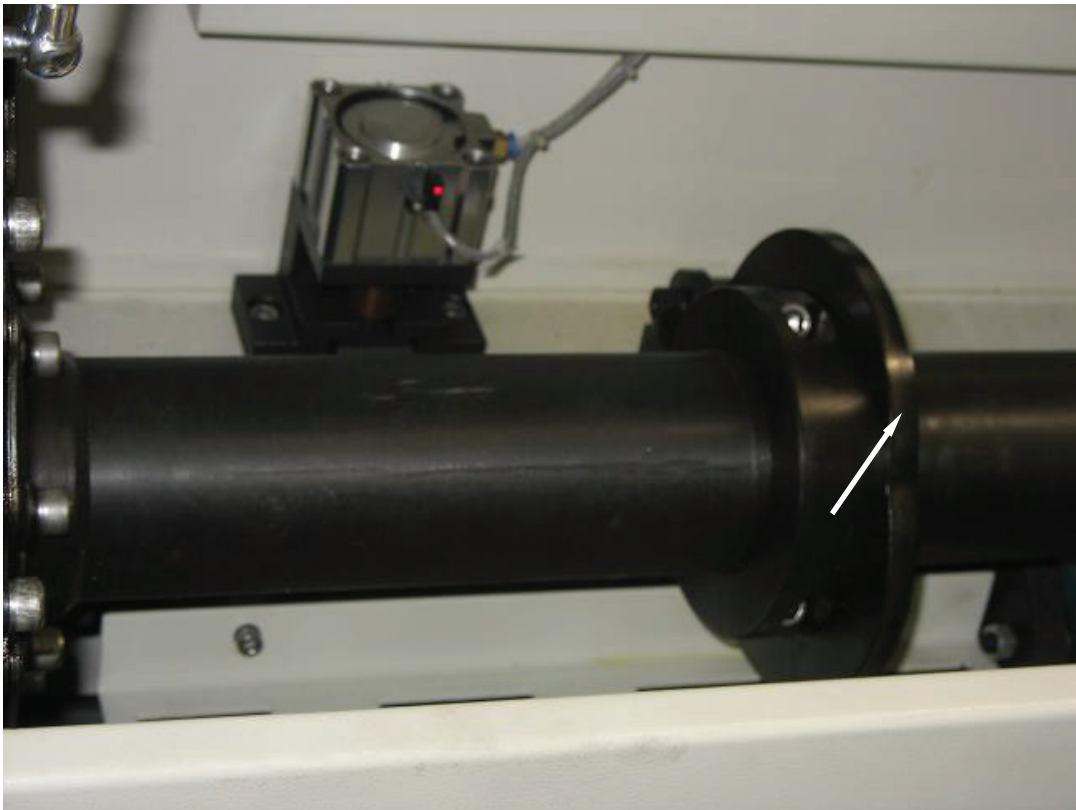

Figure 8. Feeder cam Infuse oil type: B

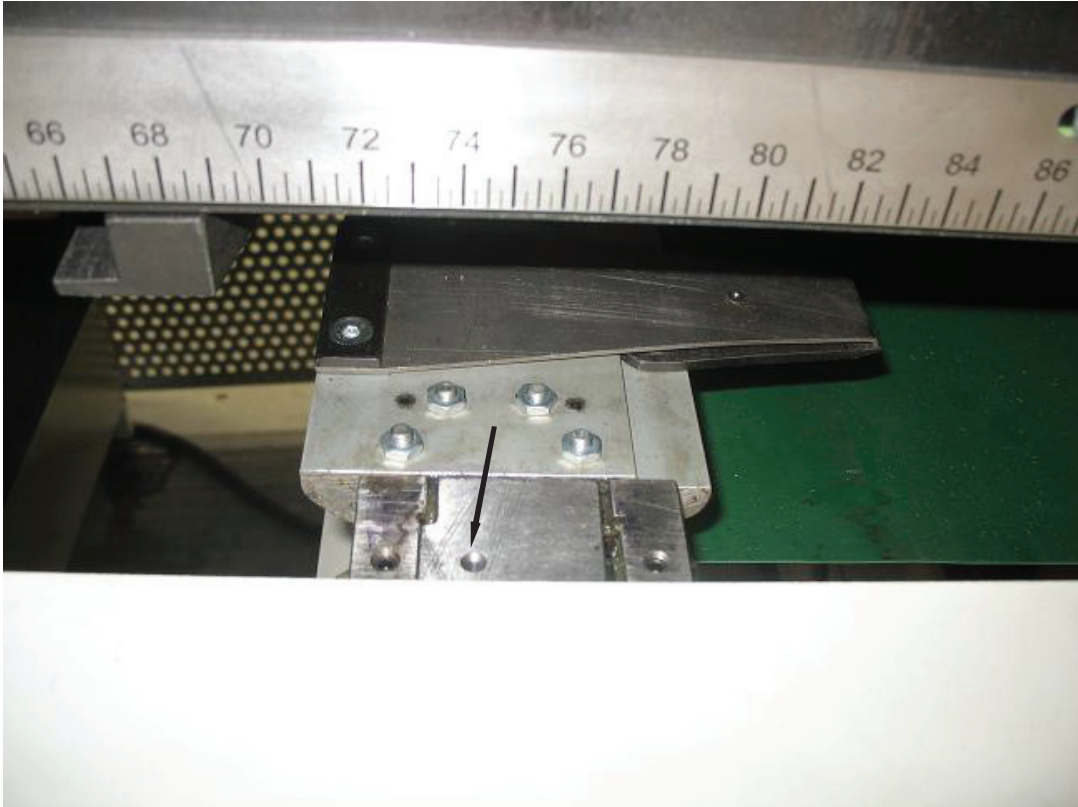

Figure 9. Gripper bar joint (8 pcs, symmetrical), oil filling type: B

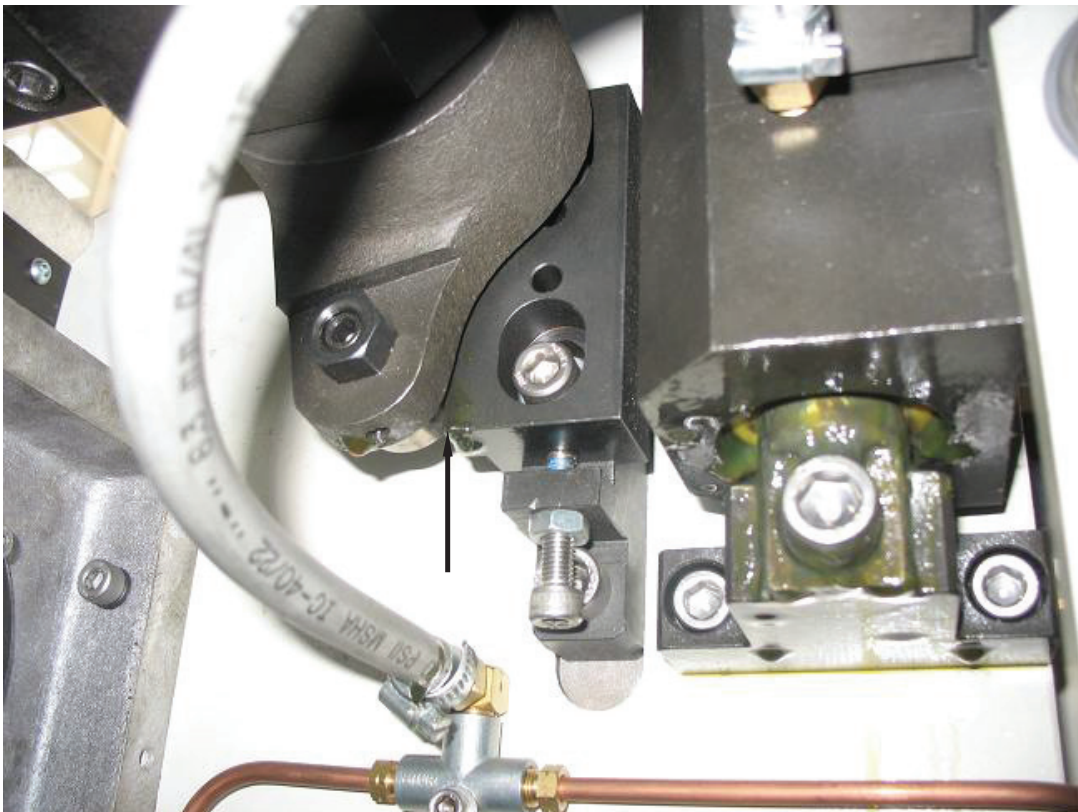

Figure 10. Gripper bar rear positioning slide block (symmetrical), oil filling type: B

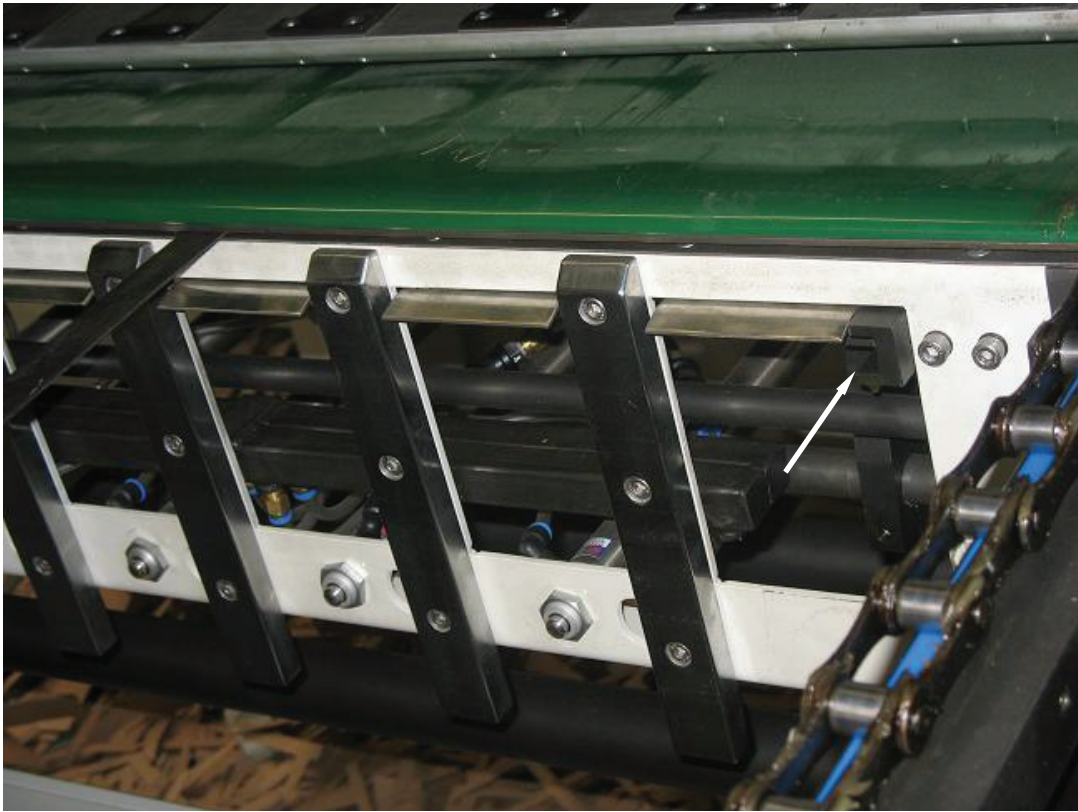

Figure 11. Rear paper support guide way (symmetrical), oil filling type: B

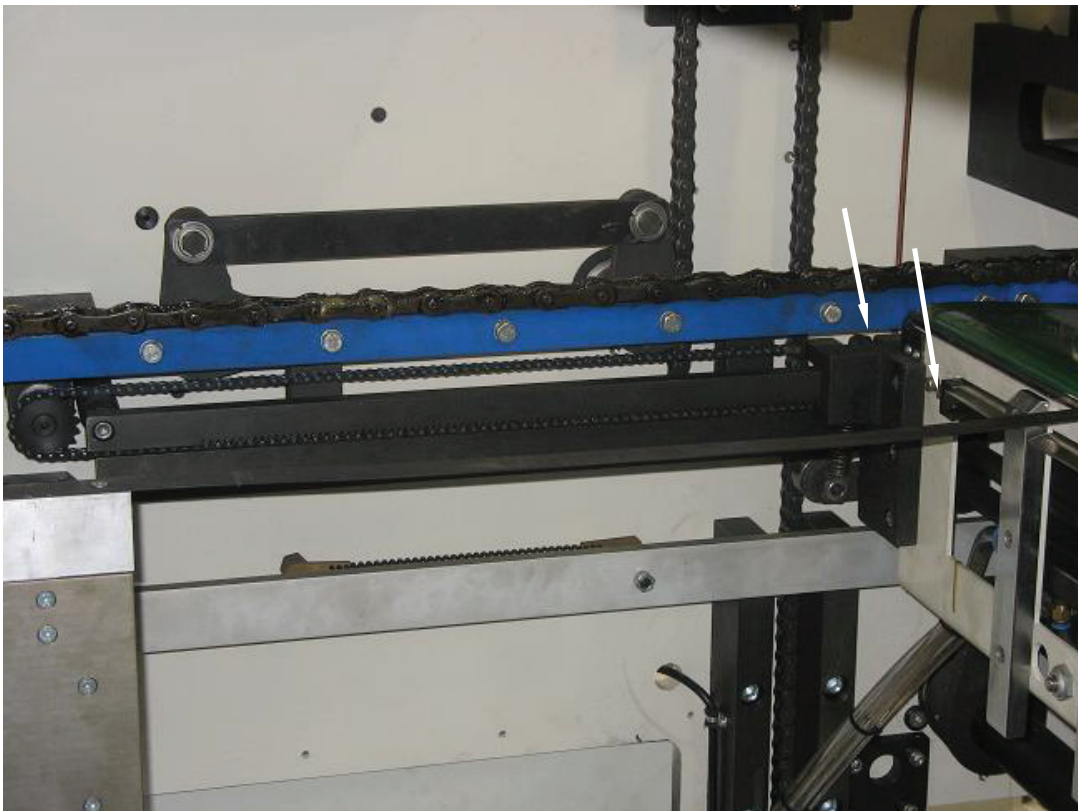

Figure 12. Delivery section backstop (symmetrical), oil filling type: B

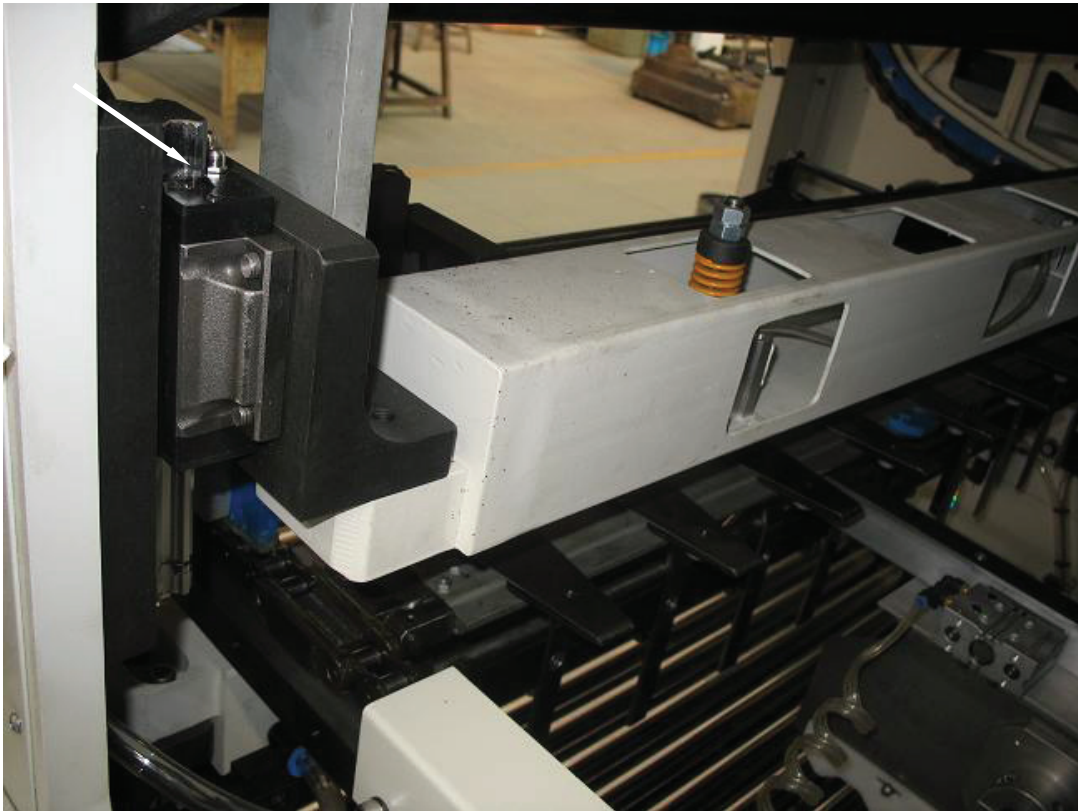

Figure 13. Upper part of stripping seat linear guideway (symmetrical), oil filling type: B

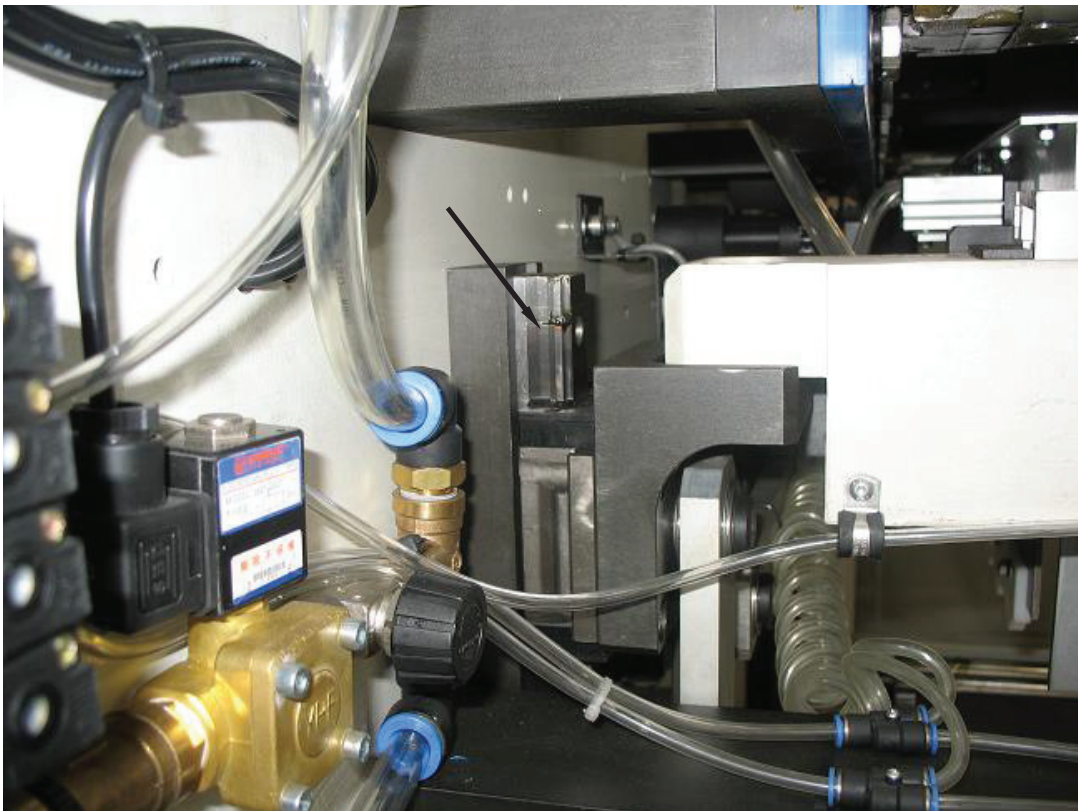
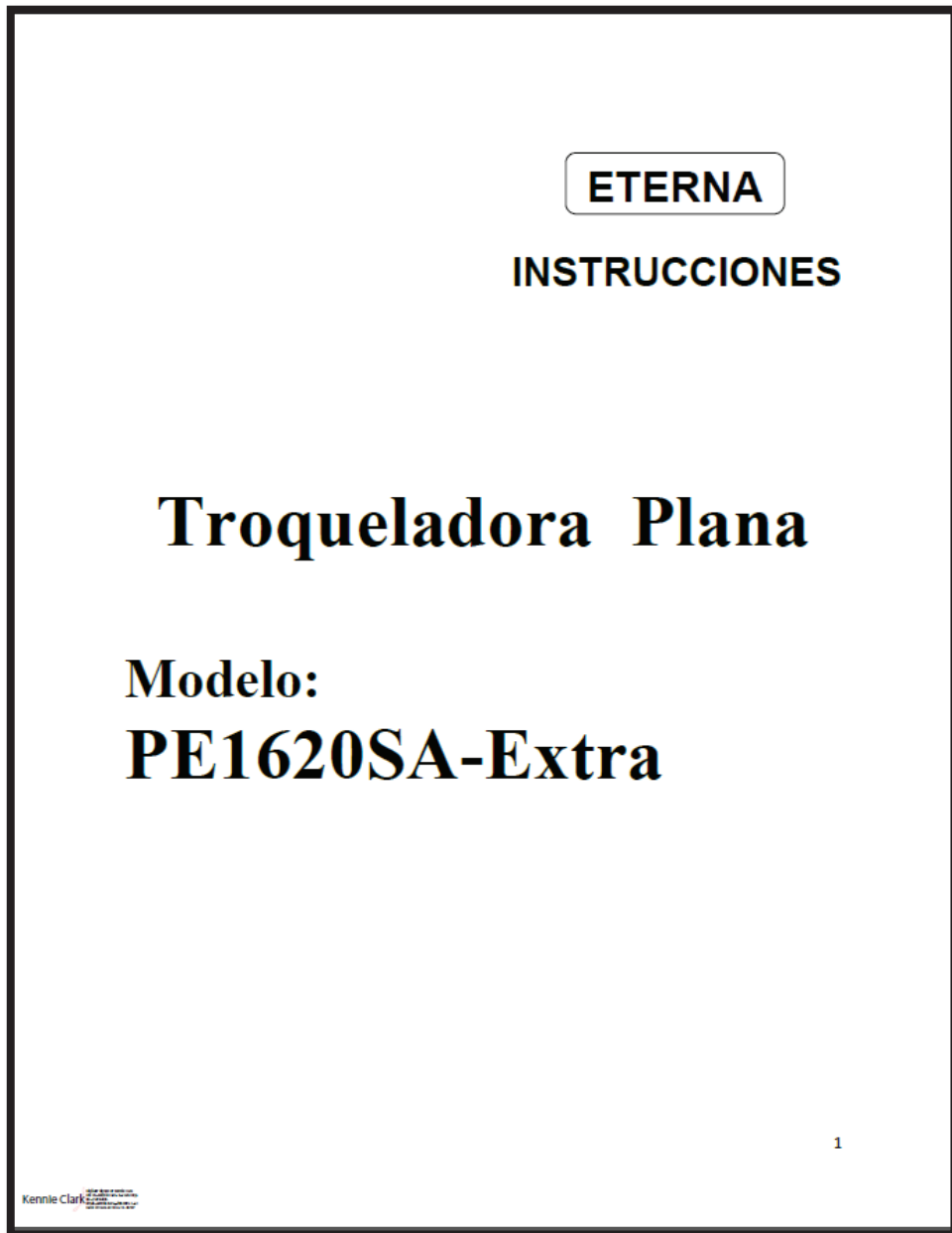

Figure 14. Lower part of stripping seat linear guideway (symmetrical), oil filling type: B

2. ETERNA PE1620SA-EXTRA MANUAL (TT - SPANISH)



ETERNA

INSTRUCCIONES

Troqueladora Plana

Modelo:

PE1620SA-Extra

INDEX

1. Control Generales de Operación
 - A. Panel de Operación – Alimentadora. Símbolo 25-35
 - B. Panel de Operación – Troqueladora. Símbolo 20, 21, 41, 50
 - C. Panel de Operación – Removedor para Desperdicios. símbolo 55-59
 - D. Panel de Operación – Tapones de Suministro y Removedor de filo frontal. Símbolo 61-65
 - E. Panel de Operación – Sistema de Suministro. Símbolo 71-86, 91, 92
 - F. Panel de Operación – Accionamiento Manual. Símbolo 39-40
 - G. Panel de Operación – Pantalla de Autodiagnóstico

2. Mando Principal
 - 2.1. Descripción
 - 2.2. Control de Velocidad
 - 2.3. Encendido del Motor y la Maquina
 - 2.4. Sincronización General
 - 2.5. Encendido
 - 2.6. Sistema de Accionamiento Manual

3. Revisión de la Lámina transportadora
 - 3.1. Funciones de las Células Fotoeléctricas

4. Protecciones Físicas
 - 4.1. Algunos Dispositivos de Seguridad
 - 4.2. Como adentrarse en la maquina
 - 4.3. Detenido de Emergencia

5. Alimentadora
 - 5.1. Operación
 - 5.2. Configurando la Alimentadora
 - 5.3. Tablero Warp

6. Troqueladora
 - 6.1. Descripción General

- 6.2. Regulador de Fuerza de Corte
- 6.3. Rodillo inmovilizado bajo presión
- 6.4. Descripción de equipo de troquelado y materiales
- 6.5. Encaje del troquel en el Molino
- 6.6. Manejo del equipo de troquelado
- 6.7. Proceso de Preparación de la Forma
- 6.8. Contrapartes de Corrugado

- 7. Removedor de Desperdicios
 - 7.1. Descripción
 - 7.2. Acenso y descenso del marco de Remoción
 - 7.3. Encaje del tablero hembra de Remoción
 - 7.4. Trabajando sin Remoción

- 8. Suministro
 - 8.1. Descripción
 - 8.2. Remoción Frontal
 - 8.3. Contador de Preselección

- 9. Montaje y Proceso de Preparación de la Forma.

- 10. Pantalla LCD

- 11. Mantenimiento y Lubricación

ESPECIFICACIONES & DATOS TECNICOS

Disponibilidad

Tablero Solido	Min.1.5mm
Tablero Corrugado	F.E.C.B.A.AB y otras categorías de hasta 9mm
Tamaño de Lámina	Max. 1620x1200mm (63 ^{5/7} " × 42 ^{1/5} ") Min. 650x450mm (25 ^{2/5} " × 17 ^{2/3} ")
Tamaño de Corte	Max. 1600x1180mm (63" × 46 ^{2/5} ")
Tamaño del Molino Interno	1630x1215mm (64 ^{1/6} " × 47 ^{3/5} ")
Tamaño de Bandeja de Corte	1650x1186mm (66 ^{4/5} " × 5065 ^{30/31} " × 46 ^{11/16} ")
Desperdicio de Pinza de Cogida (Distancia desde la primera cuchilla al borde frontal de la lámina)	Min. 12mm
Margen de Mordida de Pinza de Cogida	Min. ±3mm
Presión de Corte	Max. 400 toneladas
Potencia del Motor Principal	22KW
Potencia Total de Carga conectada	30KW
Voltaje	380V, 3PH, 50/60HZ
Peso Neto	32 toneladas
Dimensiones	9980x5670x2480mm (Largo x Ancho x Altura)

ETERNA

INSTRUCCIONES

PE1620SA-Extra

Capítulo 1

CONTROLES GENERALES DE OPERACIÓN

1. CONTROLES GENERALES DE OPERACION
A. ALIMENTADOR 25-35



25

Interruptor Del ventilador

Para encendido: coloque el interruptor en la posición 1.

Para apagado: coloque el interruptor en la posición 0.



26

Interruptor del plato de prensa del alimentador de dos posiciones

Para encendido: coloque el interruptor en la posición 1.

Para apagado: coloque el interruptor en la posición 0.



27

Presione el botón para funcionamiento continuo

Cuando este encendido, presione este botón, manténgalo presionado por 3 segundos y luego suéltelo. La máquina empezará a funcionar.



28

Pulsador de 2 etapas. Presionar para marcha intermitente.

Oprimir y soltar el pulsador, la señal de alarma se encenderá. Dentro de 3 segundos luego de que la alarma se haya detenido, pulsar el botón nuevamente. Mantener presionado para marcha intermitente. Soltar el pulsador para detener la marcha intermitente.



29

Detenido del pulsador de la máquina en forma de Hongo (Mushroom machine)

Para desembragar y detener la máquina sin detener el motor principal.



30

Interruptor de 3 posiciones para la marcha intermitente trasera.

Posicion.0: Inactivo

Posicion.1: Un golpe por cada lamina.

Posicion.3: Un golpe cada tres laminas.



31

Pulsador para ajustar la posición frontal de la guía hacia abajo.

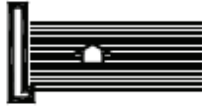

32

Pulsador para ajustar la posición frontal de la guía hacia arriba.



33

Pulsador de 3 posiciones de ajuste del indicador lateral.
Izquierda: Control de funcionamiento de superficie
Centro: Control simultaneo de funcionamiento y accionamiento
Derecha: Control accionamiento de superficie



34

Botón de Indicador de incremento lateral.



35

Botón Indicador de disminución lateral.



50

Botón de Detenido
Idéntico a grafico #50



51

Interruptor de 3 posiciones para marcha intermitente lateral (OOS):
Posicion.0: Inactivo
Posicion.1: Un golpe por lámina.

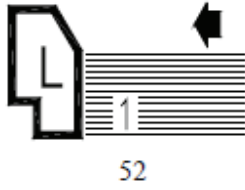

Interruptor de 3 posiciones para marcha intermitente (OS):

Posicion.0: Inactivo

Posicion.1: Un golpe por cada lamina.

Posicion.3: Un golpe cada tres laminas.



Potenciómetro para marcar el volumen de vacío del ventilador y del alimentador:

Girar el dial en dirección de las manecillas del reloj: Aumento.

Girar el dial contra las manecillas del reloj: Disminución.

A. ALIMENTADOR

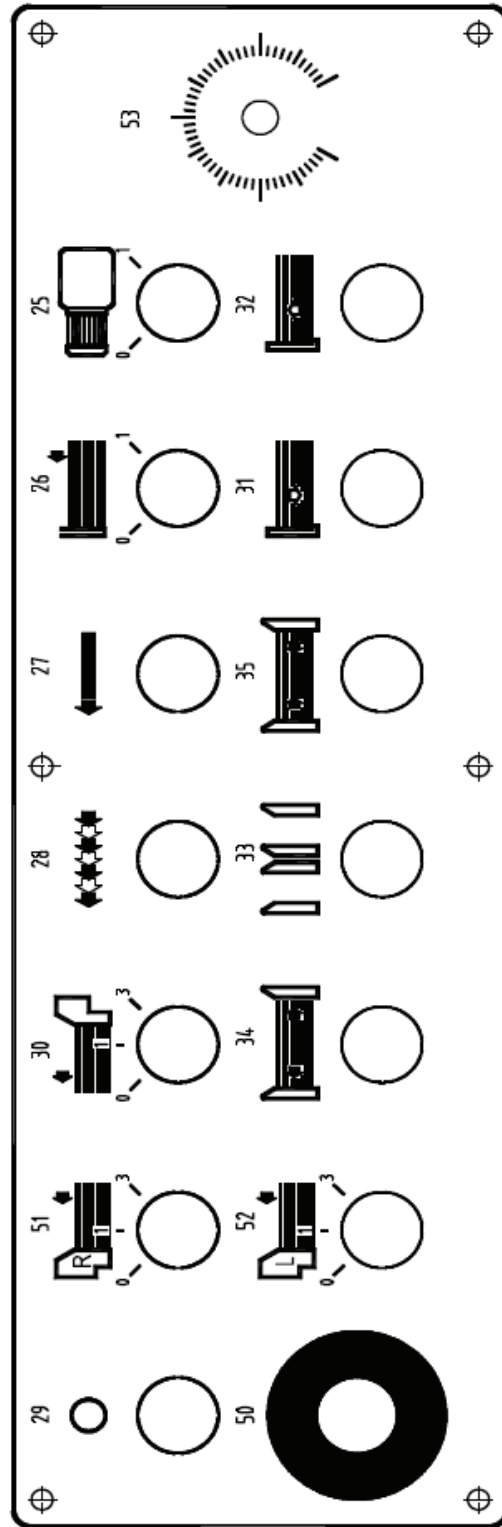

B. TROQUELADORA 20,21,41-50



20

Oprima botón para el bloqueo del Molino de troquelado,
Presione una vez para bloquearlo.
SI el Molino de troquelado está bloqueado, presiona una vez para
desbloquearlo.



21

Oprima el botón para mover el plato de prensa inferior hacia abajo, hasta la
posición “die chase out” o “mesa de troquel expulsada”
Oprima el pulsador, el plato de prensa bajara hasta la posición más baja y
se detendrá.



41

Interruptor en forma de llave.
Posición.0: Para cortar completamente la alimentación de poder hacia la
máquina.
Posición.1: Para permitir el flujo de la alimentación de poder principal de la
máquina luego de que la caja de poder ha sido encendida. El interruptor de
llave en esta posición permitirá el correcto funcionamiento del motor y de los
circuitos de control de la máquina.



42

Pulsador para controlar el motor principal.
Oprimir el pulsador para detener el motor principal.



43

Potenciómetro para marcar el incremento de velocidad.
Girar el dial en dirección de las manecillas del reloj para incrementar la
velocidad.
Girar el dial en contra las manecillas del reloj para disminuir la velocidad
luego de que el Potenciómetro ha sido accionado por el botón # 46



44

Pulsador de dos etapas para poner en marcha los circuitos de control y una
corrida continuo.
Idéntico a 27



Botón para detenido de la Máquina de Hongo (Mushroom machine).
Idéntico a 29



Pulsador luminoso para aceleración y desaceleración.
Para incrementar la velocidad, colocando el Potenciómetro (43) en la posición de la velocidad deseada. Presionar el botón, la luz del botón se encenderá. La aceleración se incrementará progresivamente hasta alcanzar la velocidad marcada en el Potenciómetro.
Oprima el pulsador nuevamente para disminuir la velocidad hasta la velocidad de gateo o velocidad más baja y constante antes de detenerse (crawling speed)

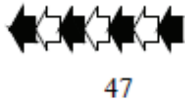

Pulsador de dos etapas para marcha intermitente.
Idéntico a 28



Interruptor para Sistema de inspección de Células Fotoeléctricas.
Posicion.0: Células Fotoeléctricas apagada.
Posicion.1: Células Fotoeléctricas prendida.

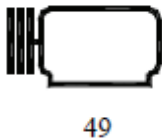

Pulsador para controlar el motor principal
Oprima el pulsador para poner en marcha el motor principal.



Botón en forma de hongo de Detenido de Emergencia.
Oprimir este pulsador para detener la Troqueladora incluso cuando el plato de prensa este en la posición más alta. El motor principal se detendrá paulatinamente alcanzando la velocidad mínima y luego se detendrá.

B. TROQUELADORA

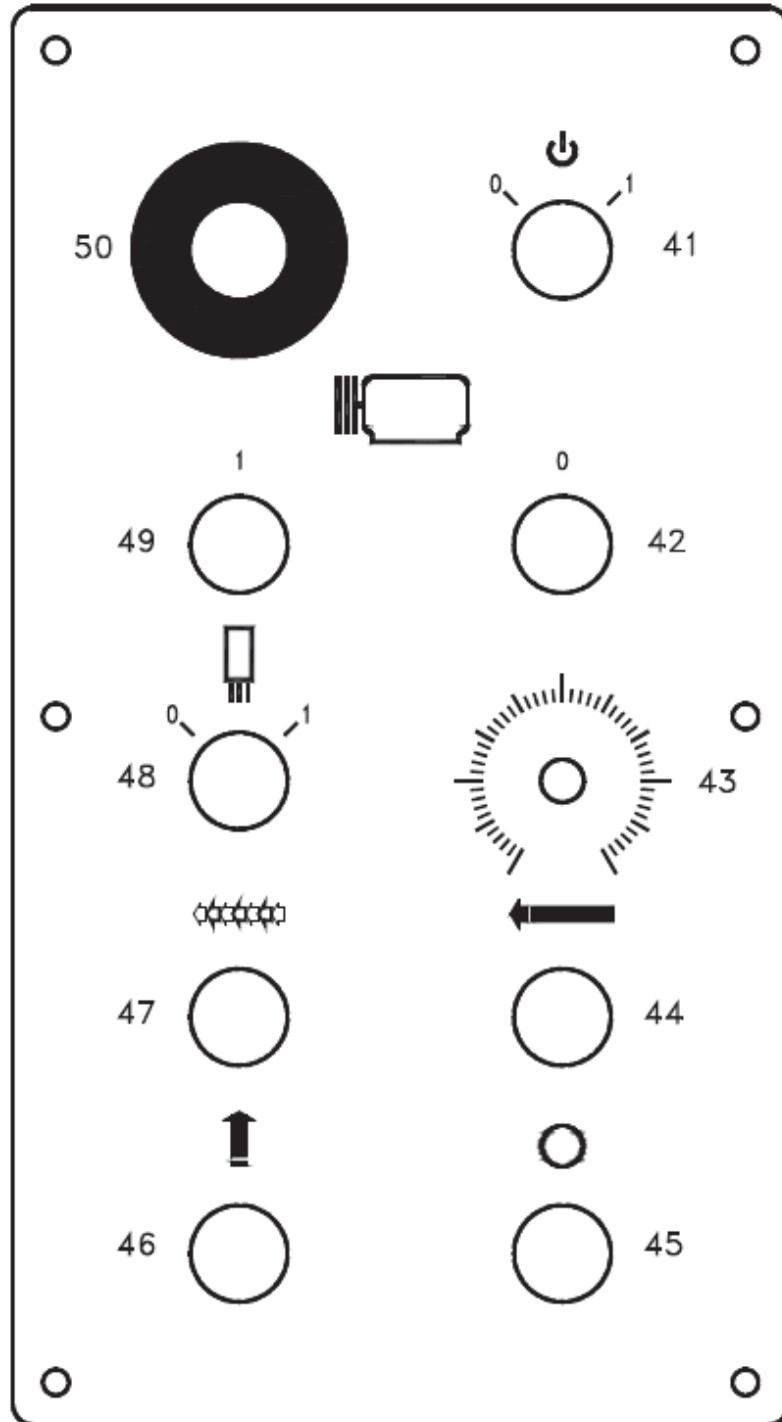

C. PROCESO DE REMOCIÓN 55-59

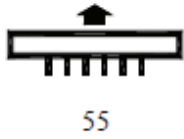

Pulsador luminoso para mover el molino superior hacia arriba.
Oprima este pulsador y manténgalo presionado. El molino superior subirá continuamente.
Suelte el pulsador para detenerlo. La luz en el botón se encenderá si el Molino alcanza la posición límite más alta, y este se detendrá.

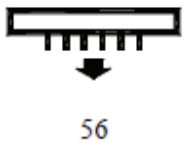

Pulsador luminoso para mover el molino superior hacia abajo.
Oprima este pulsador y manténgalo presionado. El molino superior bajará continuamente.
Suelte el pulsador para detenerlo. La luz en el botón se encenderá si el Molino alcanza la posición límite más baja, y este se detendrá.



Pulsador de dos etapas para marcha intermitente
Idéntico a 28



Pulsador de dos etapas para poner en marcha los circuitos de control y de corrida continuo.
Idéntico a 27



Pulsador para detener la Máquina en forma de Hongo (Mushroom machine)
Idéntico a 29

C. REMOCIÓN DE DEPERDICIOS

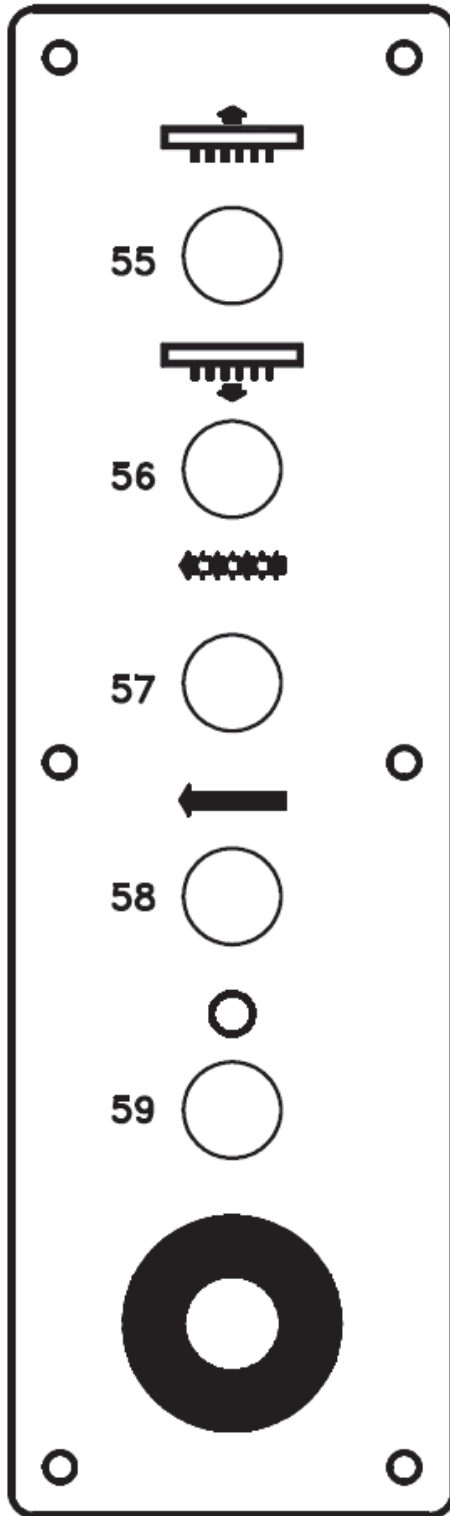

D. TAPONES DE SUMINISTRO Y REMOVEDOR DE FILO FRONTAL

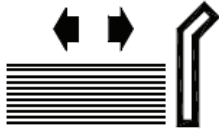

61

Interruptor de Pivote luminoso para mover los tapones de suministro hacia delante y hacia atrás.
Girar hacia la izquierda y mantenerlo en esa posición para mover el tapón hacia delante de forma continua.
Soltar el interruptor de pivote para detener.
Girar hacia la derecha y mantenerlo en esa posición para mover el tapón de suministro hacia atrás.
La luz del interruptor de pivote se encenderá si el tapón llega al tope en cada lado.



62

Interruptor para Motriz de empuje de láminas.
Línea Rota: Motriz de empuje de lámina Detenido.
Línea Real: Motriz de empuje de lámina Operativo.



63

Interruptor de abertura de pinza de cogida de remoción frontal de desperdicio.
Izquierda: Cerrado
Derecha: Abierto (Abre las pinzas de cogida y libera el desperdicio frontal, la lámpara se encenderá).



64

Interruptor luminoso de dos posiciones para bloquear y desbloquear la herramienta de filo superior frontal para remoción de desperdicio.
Izquierda: Desbloquear (La luz se encenderá para indicar que la herramienta está lista para ser usada)
Derecha: Bloqueado (Para sujetar la herramienta de filo superior frontal para remoción de desperdicio a la transportadora)



65

Interruptor luminoso de dos posiciones para bloquear y desbloquear la herramienta de filo inferior frontal para remoción de desperdicio.
Izquierda: Desbloquear (La luz se encenderá para indicar que la herramienta está lista para ser usada)
Derecha: Bloqueado (Para sujetar la herramienta de filo superior frontal para remoción de desperdicio en el contenedor)

D. TAPONES DE SUMINISTRO Y REMOVEDOR DE FILO FRONTAL

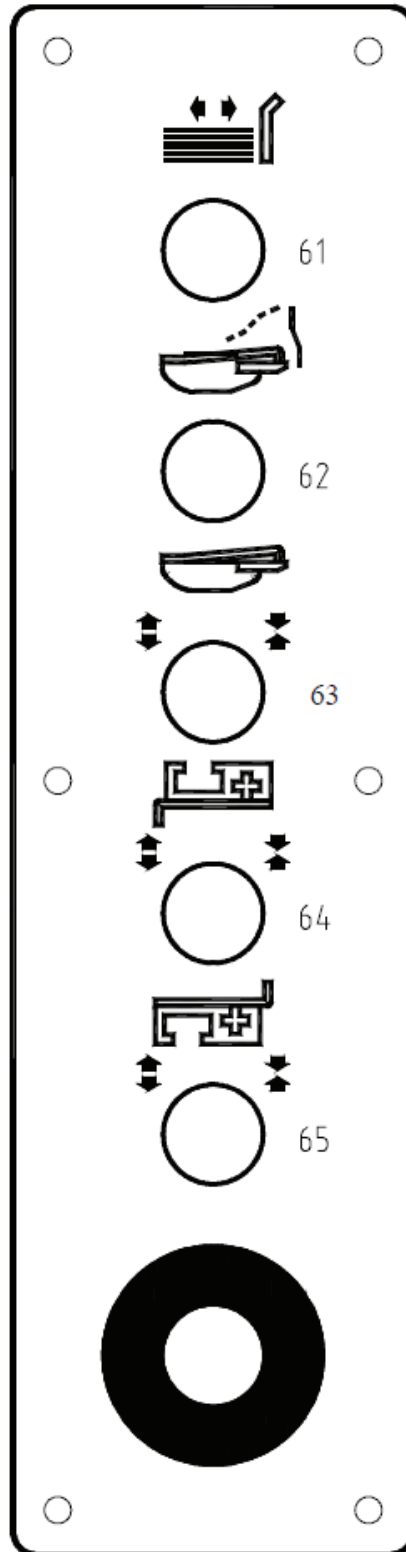

E. SUMINISTRO



71

Interruptor de dos posiciones para encender y apagar en contador.
Posición.0: Apagado.
Posición.1: Encendido.



72

Pulsador para interrumpir el soplador del alimentador
Oprimir este pulsador para detener el soplador del alimentador

73

Preseleccionar contador de lotes para indicar el número de láminas para ser agrupadas en suministro.
Oprimir el botón debajo de cada dígito del dial para permitir la preselección del número de láminas para ser puestas en lotes.



74

Interruptor de tres posiciones de control de contador/eyector.
El cilindro auxiliar aparecerá cuando la cantidad preseleccionada de láminas se agrupen en su totalidad para apilar las láminas del siguiente lote.
Durante el proceso, puede haber intervalo de láminas.
Posición.1: No existe intervalo de láminas en la cantidad preseleccionada del lote.
Posición.2: Intervalo de 1 lámina en el número de la cantidad preseleccionada del lote.
Posición.3: Intervalo de 3 láminas en la cantidad preseleccionada del lote.



75

Interruptor de dos posiciones para encender y apagar la
Cinta transportadora de remoción de desperdicio frontal.
Posición.0: Apagado.
Posición1: Encendido.

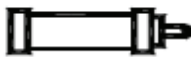

76

Pulsador Luminoso para retirar el cilindro auxiliar.
Oprimir este pulsador para retirar el cilindro auxiliar. La luz del botón se encenderá para indicar el estado.



77

Pulsador de dos posiciones para encender los circuitos de control y la
corrida continua.
Idéntico a 27.



78

Pulsador para detenido de la máquina de Hongo (Mushroom Machine)
Idéntico a 29.



79

Pulsador Luminoso para aceleración y desaceleración de la velocidad.
Idéntico a 46.



80

Pulsador de dos etapas ara marcha intermitente. (jogging)
Idéntico a 28.



81

Pulsador Luminoso para sacar el cilindro auxiliar.
Oprima este botón para sacar el cilindro auxiliar. La luz en el botón se encenderá para indicar el estado.

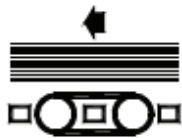

82

Interruptor de dos posiciones de cinta de suministro.
Posición.1: Apilado automático de láminas para pasar a la mesa de suministro (cuando la máquina está en marcha).
Posición.2: Apilado Manual de láminas para pasar a la mesa de suministro (cuando la máquina no está operativa)

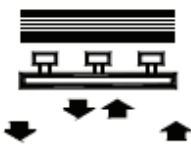

83

Interruptor de dos posiciones para el control de la bandeja de carga de suministro principal hacia arriba y hacia abajo.
Izquierda: Hacia Abajo.
Derecha: Hacia Arriba.

84

Temporizador para fijar la distancia de descenso recorrido de la bandeja de carga de suministro principal.
Girar el dial para fijar el tiempo deseado para permitir el descenso de la bandeja de carga principal.



85

Pulsador para inicializar el soplador del alimentador.
Presionar el botón para inicializar el soplador del alimentador.

86

Contador de láminas en cero para restaurar la perilla en la base de la unidad.



87

Botón de Detenido de Emergencia.
Oprimir este pulsador para detener la troqueladora incluso con el plato de prensa en posición elevada.
El motor principal se alcanzará su velocidad mínima y se detendrá.

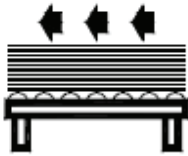

91

Interruptor de dos posiciones para la bandeja de carga de suministro auxiliar.
Idéntico a 82.



92

Pulsador para detenido de Máquina de Hongo (Mushroom machine)
Idéntico a 29.

F. ACCIONAMIENTO MANUAL



39

Interruptor de dos posiciones para accionamiento manual
Posicion.0: De acuerdo a estado de la operación de la máquina. (El Accionamiento manual no está permitido.)
Posicion.1: Listo para Accionamiento manual. Insertar y presionar el trinquete para accionar el embrague. Ahora la máquina está lista para accionamiento manual.



40

Pulsador para detenido de Máquina de Hongo (Mushroom machine)
Idéntico a 29.

E1: SUMINISTRO

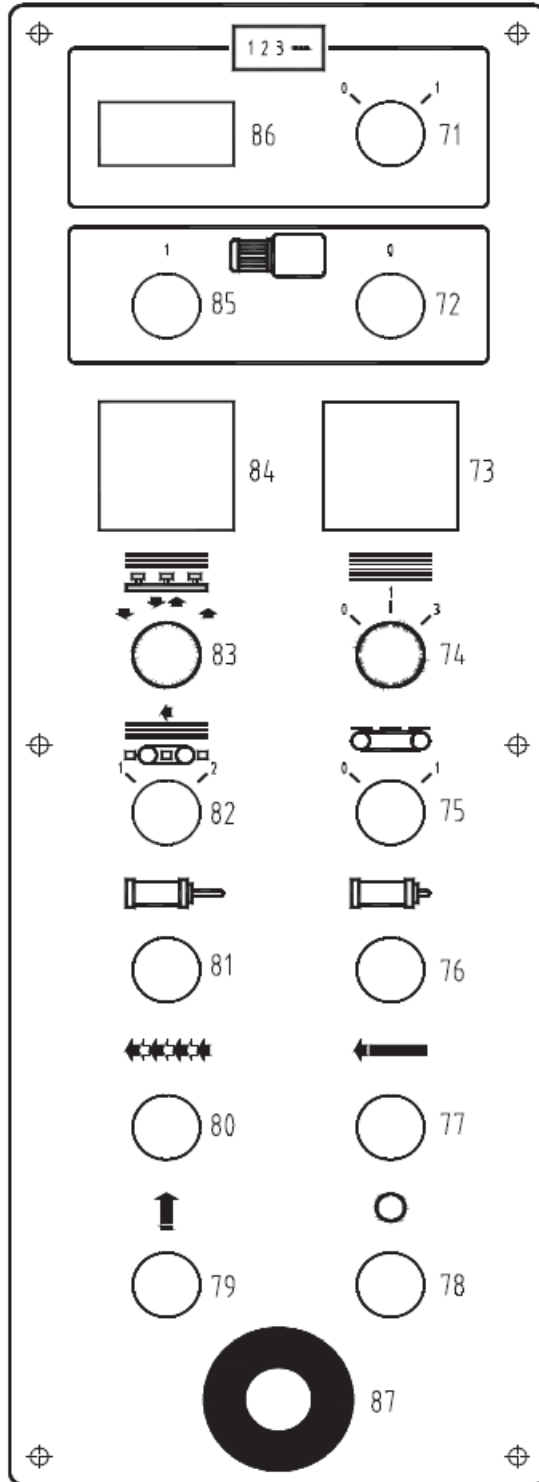

E2: SUMINISTRO

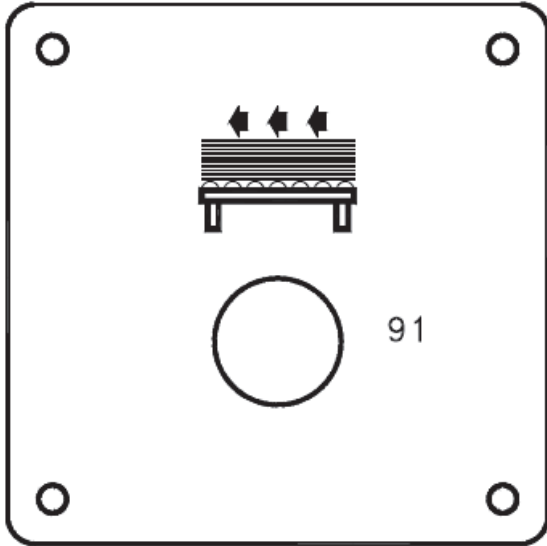

F: ACCIONAMIENTO MANUAL

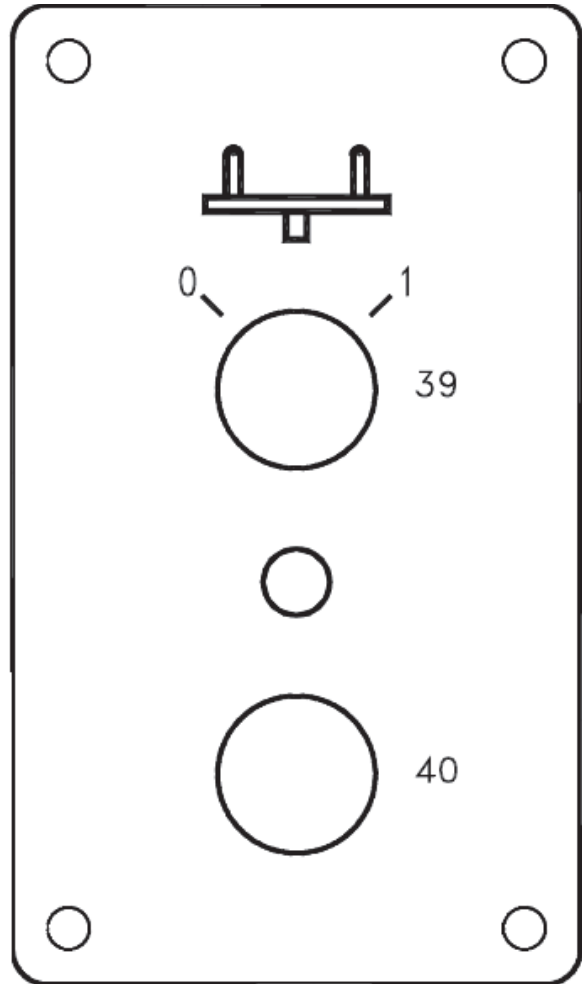

E3: SUMINISTRO

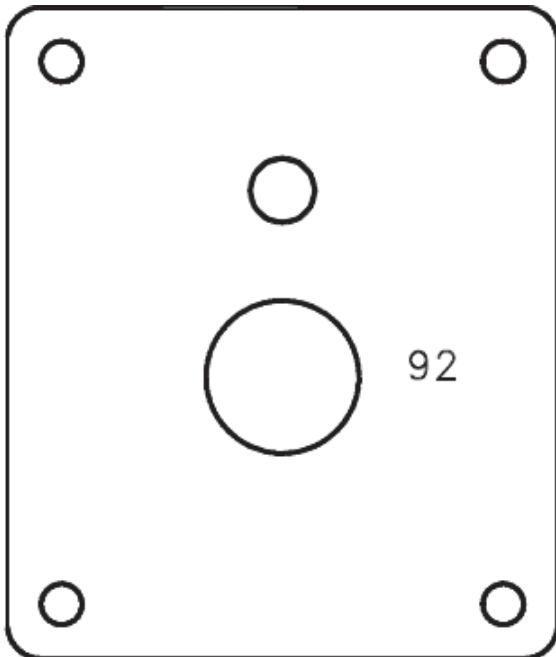

G. PANEL DE OPERACIÓN – PANEL/PANTALLA DE AUTODIAGNÓSTICO



1

Luz indicadora. Muestra que la alimentación de poder principal está funcionando.



2

Luz indicadora. Muestra que la alimentación de Corriente Directa está funcionando.



3

Luz Indicadora, mostrando el funcionamiento del PLC.



4

Luz indicadora, Muestra presión de aire insuficiente del compresor o Fuente principal de aire de fábrica. Embrague/freno neumático no está operativo



5

Luz Indicadora, Muestra el desenganche del límite de acoplamiento para torque.



6

Luz Indicadora, Muestra Detenido de emergencia accionado.



7

Luz Indicadora, Muestra Detenido Ordinario encendido.



8

Luz Indicadora, Muestra que una de las protecciones de seguridad no está cerrada.

9

Luz Indicadora, Muestra problemas con el suministro, la lámina no ha sido liberada en el suministro.

10

Luz Indicadora. Muestra la pila de láminas en suministro cuando sobrepasa el límite de altura. Cuando sucede esto, la máquina se detiene, y la alarma es accionada.

- 11 Lámpara Indicadora – dificultades con el transporte de las láminas en la parte de salida de la estación de remoción de desperdicios.
- 12 Lámpara Indicadora – dificultades con el transporte de las láminas en la parte de salida de la estación de troquelado.
- 13 Luz Indicadora, Muestra que el Molino de corte no está bloqueado.
- 14 Luz Indicadora, Muestra que la plancha de troquelado no está empujada hasta su posición final.
- 15 Luz Indicadora, Muestra que la presión del aceite en el circuito de ciclo principal está muy bajo o relé de bomba térmica está atascado.
- 16 Luz Indicadora, Muestra que el borde frontal de la lámina está desalineada en la posición frontal.
- 17 Luz Indicadora, Muestra que el detector de láminas dobles ha sido accionado.
- 18 Luz Indicadora, Muestra la llegada temprana de la lámina en la entrada de alimentación
- 19 Luz Indicadora, Muestra que el motor principal ha sido sobrecargado.

G. LUZ DEL INDICADOR

WISTA HORIZONTAL

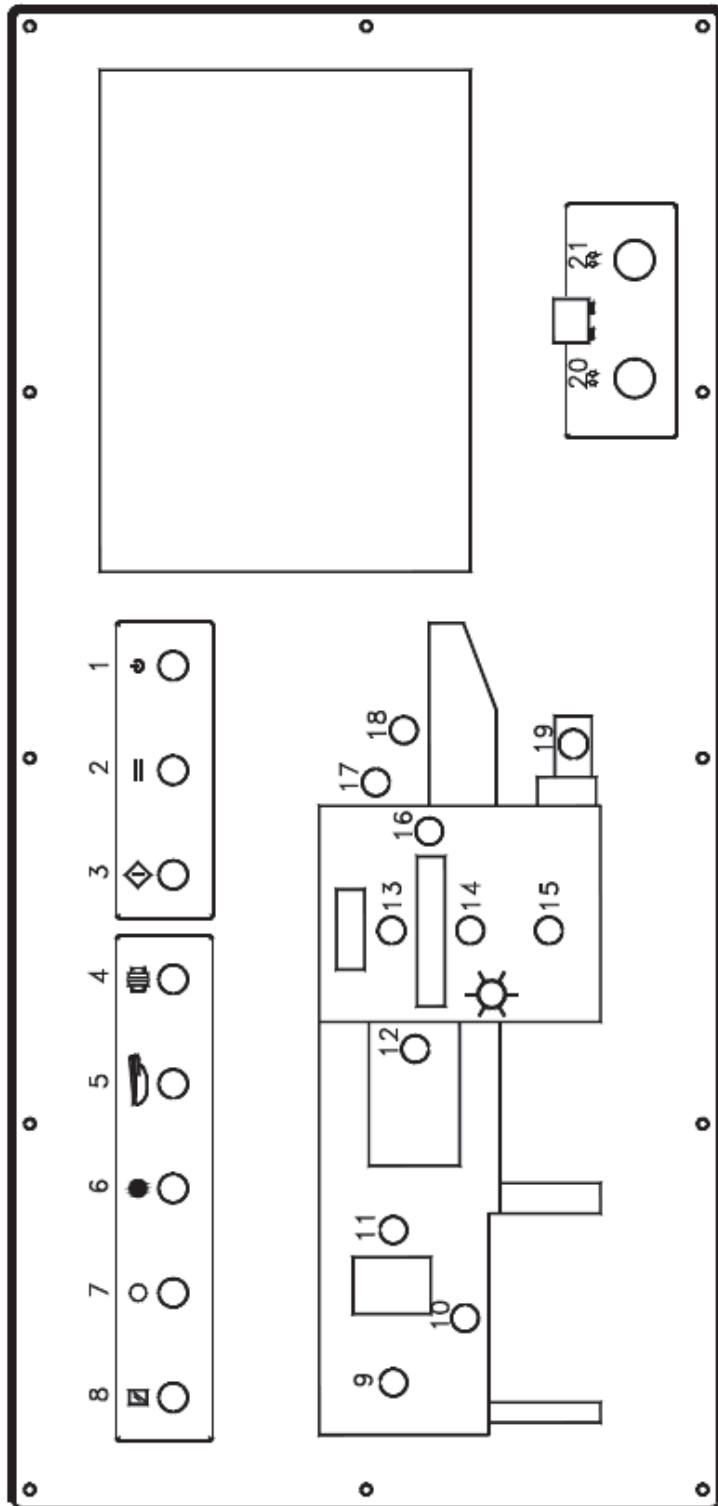

B-C. CELULA FOTELECTRICA DE SALIDA DE LA REMOVEDORA (STRIPPER OUTLET PHOTOCELL)



95

Interruptor para Célula Fotoeléctrica de salida del removedor de desperdicios.
Posición.1: Lado Operativo: Sensor para detección de lámina expulsada.
Posición.2: Lado de Manejo: Sensor para detección de lámina expulsada.
Posición Media: Sensor para detección de lámina expulsada, para ambos o.s. y o.o.s. (Lado del operador y lado opuesto al operador)



96

Interruptor de tres posiciones para Célula Fotoeléctrica de salida del troquelado.
Posición.1: Lado Operativo: Sensor para detección de lámina expulsada.
Posición.2: Lado de Manejo: Sensor para detección de lámina expulsada.
Posición Media: Sensor para detección de lámina expulsada, para ambos o.s. y o.o.s.

C2 INTERRUPTOR DE LLAVE PARA DETENIDO DE MÁQUINA (En la sección de remoción de desperdicios del lado opuesto del operador)



Posición.0: Interruptor de llave está activado, la máquina se detiene.
Posición.1: Interruptor de llave no está activado, la máquina opera con normalidad.

B-C: CÉLULA FOTOELÉCTRICA DE SALIDA DE TROQUELADO Y REMOCIÓN

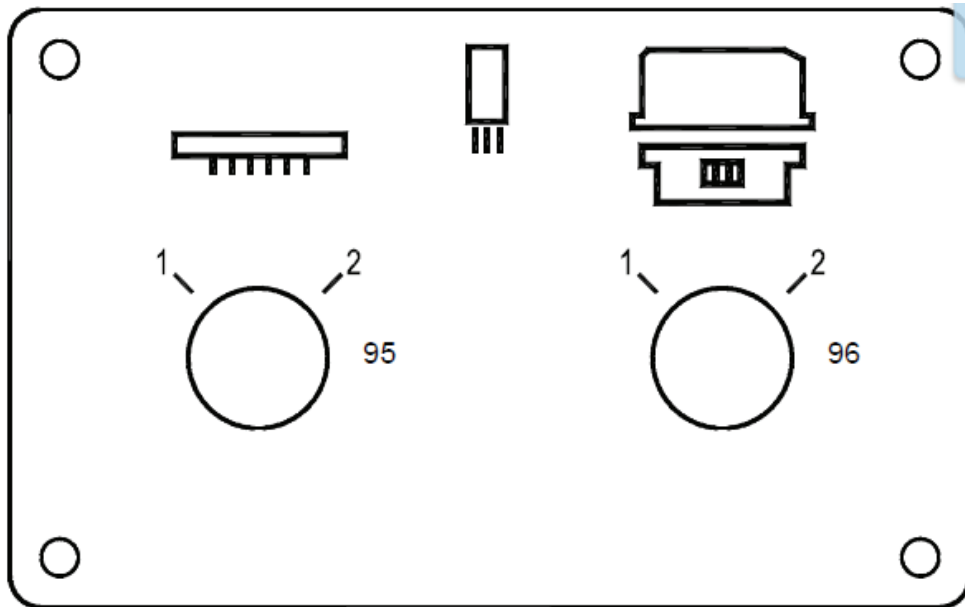

C2: INTERRUPTOR DE LLAVE PARA DETENIDO DE MÁQUINA

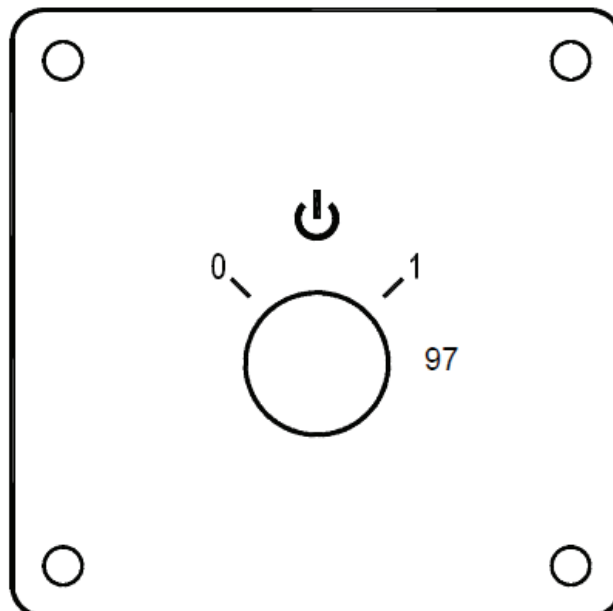

ETERNA

**INSTRUCCIONES
PE1620SA-Extra**

Capítulo 2

ACCIONAMIENTO PRINCIPAL

2. MECANISMO DE ACCIONAMIENTO MANUAL

2.1. DESCRIPCIÓN

La máquina funciona con un motor de Corriente Alterna de tres fases, con control invertido de velocidad.

El motor conduce al engranaje de tornillo perenne usando un volante y un freno/embrague neumático. El embrague opera cuando el botón de marcha intermitente (27) es presionado o cuando el botón de corrida continua (27) es presionado. El engranaje de tornillo perenne mueve la viga más baja del plato de prensa mediante un mecanismo consistente de un volante de manivela y cabillas.

2.2. CONTROL DE VELOCIDAD

La velocidad del motor de la máquina es fijado mediante un inversor, controlado por un potenciómetro.

Potenciómetro en cero = Velocidad mínima de la máquina, siendo esta 1200 ciclos/hora.

Potenciómetro en 10 = Velocidad máxima de la máquina, siendo esta 4500 ciclos/hora.

Para incrementar la velocidad, coloque el potenciómetro en la posición que representa la velocidad deseada.

Presione el pulsador (46), la luz del botón deberá encenderse; luego, con aceleración progresiva hasta el nivel fijado. Presionar el pulsador nuevamente para disminuir la velocidad hasta la velocidad de gateo.

2.3. ARRANQUE DEL MOTOR Y DE LA MÁQUINA

Luego de encender el motor principal, un temporizador de 10 segundos previene el embrague de la máquina siempre y cuando el motor y el volante no hayan alcanzado su velocidad tope.

Presionar una vez el botón de marcha intermitente o de marcha continua, solamente hace funcionar una alarma.

Cuando la alarma se detiene, el botón tiene que ser presionado de nuevo para hacer arrancar la máquina.

2.4. SINCRONIZACIÓN GENERAL

La sincronización general, así como también la revisión de transporte operada por sensor, controlada por el PLC, mediante un codificador unido al mecanismo de accionamiento principal. Y la sincronización general de la temporización de transporte de láminas, puede ser ajustada usando un programa de LCD en un PLC (Controlador de lógica programable) mediante una pantalla de cristal líquido.

2.5. ARRANQUE

1. Encienda el interruptor principal
2. Gire el interruptor (41) para encender los circuitos de control
3. Encienda el motor principal con el pulsador (42)
4. Gire el interruptor (48) para accionar el sensor de detección de circuitos
5. Encienda la bomba de arranque a presión usando el interruptor (25)
6. Oprima el pulsador (47) para marcha intermitente o el pulsador (44) para corrida continua

2.6. MECANISMO DE ACCIONAMIENTO MANUAL

Accionamiento Manual es necesario en los siguientes casos:

1. Para sacar el plato de prensa de su posición fija en la parte superior, si es que la marcha intermitente no es suficiente (ver 6.3)
2. Para restaurar el dispositivo de acoplamiento para limitar el torque.

Proceda de la siguiente forma:

1. Detenga el motor principal No presione ningún detenido de emergencia, ya que al hacer esto, el pulsador para soltar el freno quedará no operativo.
2. Inserte y presione el trinquete al final del eje (fig. 2.3). Coloque el interruptor de seguridad (39) en la posición 1. El embrague estará encendido. Opere el trinquete (ver fig. 2.1)

Derecha: Corrida en Reversa.

Izquierda: Corrida hacia delante.

3. Coloque el interruptor (39) en la posición 0. Remueva la manivela de arranque del trinquete, jale la palanca hacia abajo y saque el engranaje para separar el eje y el mecanismo de accionamiento manual. Jale la palanca hacia abajo para desenganchar el embrague al final del eje del mecanismo de accionamiento principal.

4. Para restaurar el dispositivo de acoplamiento para limitar el torque.

Cuando el movimiento de la barra de pinzas de cogida. forzado disminuir la velocidad o a detenerse debido a cualquier obstáculo y la fuerza contraria resultante el mayor al límite puesto para el torque, el Dispositivo de acoplamiento para limitar el torque será desconectado para prevenir que el sistema índice y el mecanismo de accionamiento principal sean afectados por el shock. En caso de ocurrir, la luz del indicador 5 se encenderá para mostrar que se ha realizado el desenganche del embrague del dispositivo de acoplamiento para limitar el torque, y que el tiempo de ejecución para la barra de las pinzas de cogida con la máquina principal se ha agotado. En este caso, el dispositivo de acoplamiento para limitar el torque deberá ser restaurado siguiendo las siguientes indicaciones:

- a. Abra la puerta transparente de seguridad en la alimentación de entrada.
- b. Encaje la llave en el reborde o pestaña del diente de la cadena de engranaje con la barra de extensión.
- c. Gire la llave hacia abajo hasta que el dispositivo regrese a la posición de la llave. Al hacer esto se podrá apreciar un sonido como un "clic". (ver fig. 2.1)
- d. Oprima el botón 49 (P1-7) y revise las luces del indicador para constatar que está apagado. Si está apagado, el dispositivo limitante de torque queda restaurado. Si el pulsador 49 no funciona y las luces indicadoras están encendidas, se necesitará repetir los pasos del 1 al 3.
- e. Saque la llave y cierre la puerta.
- f. Manualmente opera la máquina según los pasos mencionados en 1, 2, 3 para comprobar si la temporización entre la barra de pinzas de cogida y la máquina está correcta. Si así lo es, la máquina está lista para efectuar otra corrida.

LIMITE DE EMBRAGUE PARA TORQUE

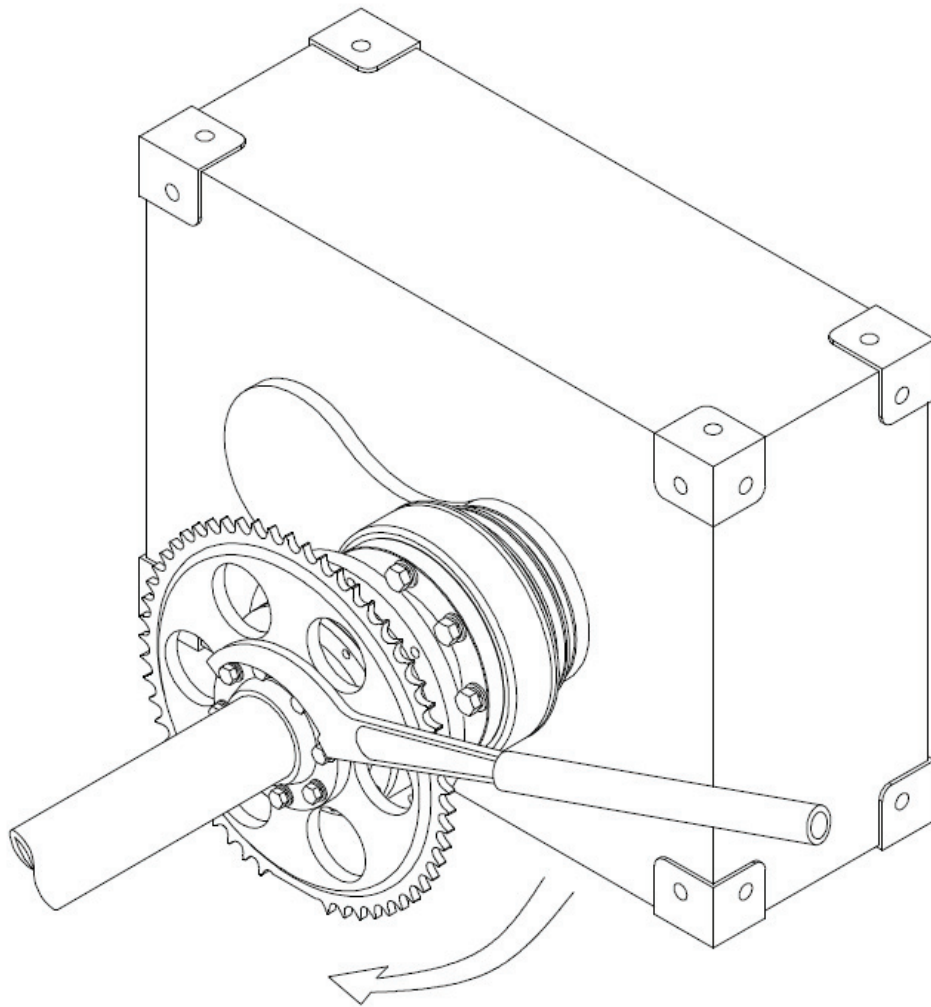
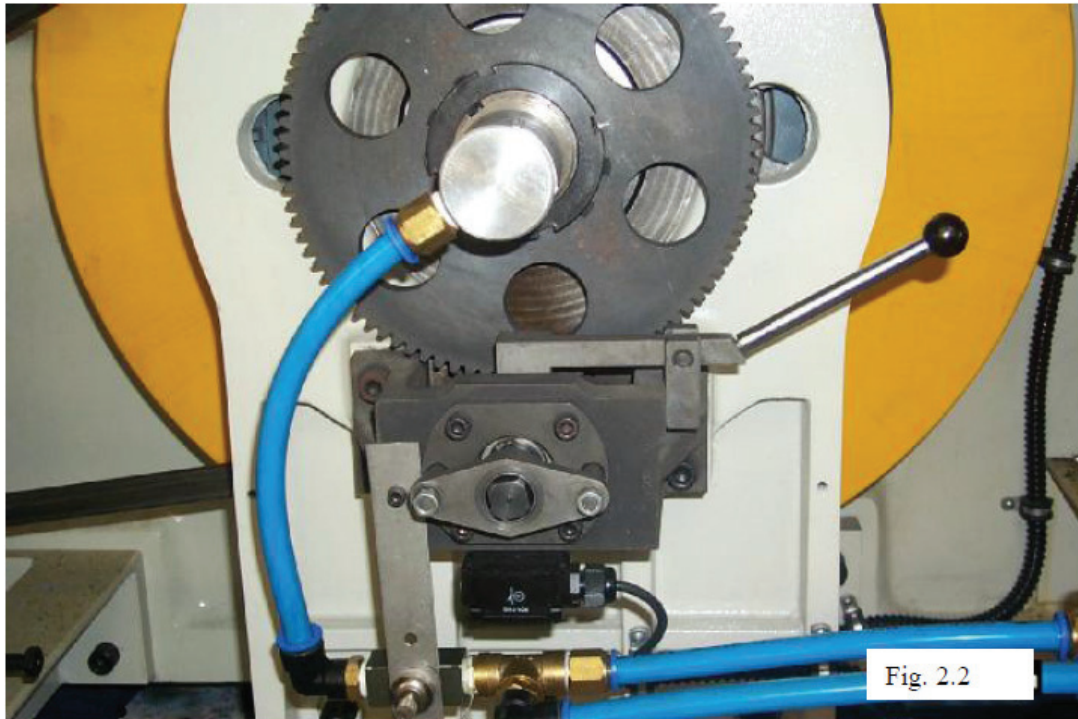

Fig. 2.1



Trinquete reducido y sistema de seguridad para el mecanismo de accionamiento manual



Inserte y empuje la llave del trinquete al final del eje.

ETERNA

**INSTRUCCIONES
PE1620SA-Extra**

Capítulo 3

REVISIÓN DE LÁMINA TRANSPORTADORA

3. REVISIÓN DE LÁMINA TRANSPORTADORA

3.1. FUNCIONES DE LAS CÉLULAS FOTOELÉCTRICAS (fig. 3.1)

3.1.1. Célula Fotoeléctrica de alimentación de entrada (18)

La Célula Fotoeléctrica está en la parte más alta, apuntando hacia abajo.

Propósito:

Revisa si la lámina llega temprano. Cuando la máquina está en 200°—205° grados, la célula fotoeléctrica de alimentación de entrada PH2 revisa la llegada de la lámina, si la lámina llega, la luz 18 se enciende, y la máquina se detiene.

3.1.2. Célula Fotoeléctrica del *Front Lay*(16)

Dos Células Fotoeléctricas de fibra en el fondo.

Propósito:

- 1) Para revisar el tiempo de llegada de la lámina en el *front lay*.
- 2) Justo después de la barra sujetadora comience a moverse, se revisa si es la lámina ha sido llevada. Si no se llega a detectar lámina alguna, pero la Célula Fotoeléctrica de alimentación de entrada (18) sí la detectó. La máquina se detendrá.

3.1.3. Célula Fotoeléctrica de la desembocadura del plato de prensa (12)

La célula fotoeléctrica está en la parte más alta y apuntando hacia abajo

Propósito:

- 1) Si la Célula Fotoeléctrica (16) ha detectado la lámina durante ciclos previos, la Célula Fotoeléctrica (12) revisa si esta ha aparecido en la desembocadura del plato de prensa. La lámina es revisada en una posición desde el borde frontal, en un punto previamente escogido, el cual es determinado por el disco ajustable del programa en el PLC. La Célula Fotoeléctrica detecta si es que la lámina ha aparecido en su totalidad desde la sección del troquelado, desde una posición en la mesa troqueladora de apoyo. Si ninguna lámina es detectada, se mostrará que la lámina ha caído en la sección de troquelado, entonces la lámpara 12 deberá encenderse y la máquina se detendrá.
- 2) Revisa si el espacio entre el borde de la lámina y la siguiente barra sujetadora está disponible, lo que significa que la lámina no ha sido puesta dentro del removedor. En caso de falla, las lámparas se encenderán y la máquina se detendrá.

3.1.4. Célula Fotoeléctrica del extremo del Removedor de Desperdicios (11)

La Célula Fotoeléctrica está en la parte más alta, apuntando hacia abajo.

Ajustar la posición lateral de la Célula Fotoeléctricas para asegurarse que esté puesta en el lugar indicado.

Propósito:

Indéntico a la Célula de la desembocadura del plato de prensa.

Además, estas Células Fotoeléctricas proveen el coteo de pulsos necesarios para la separación de lotes. En caso de falla, la lámpara (11) se encenderá y la máquina se detendrá.

3.1.5. Célula Fotoeléctrica de Centro de Suministro

La Célula Fotoeléctrica de tres reflexiones está montada opuesta a su reflector.

Propósito:

- 1) Revisar si el papel cae con normalidad en la sección de suministro.
- 2) Una configuración errónea del contador puede causar un apilamiento excesivo de papel. En caso de falla, la lámpara (10) se encenderá y la máquina se detendrá.

3.1.6. Célula Fotoeléctrica de Altura de apilado de Suministro (10)

La célula de reflexión está montada opuesta a su reflexión

Propósito:

- 1) Revisa si existe alguna obstrucción antes de que el cilindro salga.
- 2) Revisa el alza y el detenido de la plataforma principal de elevación y el retiro del cilindro.

3.1.7. Célula Fotoeléctrica de contador/eyector de Suministro del Cilindro Auxiliar (10A)

La célula de reflexión está montada opuesta a un reflector.

Propósito:

Revisar si está despejado antes de que el cilindro salga. En caso de falla, lámpara (10A) se enciende y la máquina se detiene. Además, revisa la llegada de la plataforma principal, detiene la plataforma principal, los cilindros se retiran.

3.1.8. Célula de Suministro de salida (9)

La célula de reflexión está montada opuesta a una reflexión.

Propósito:

Revisa si la pila de papel es expulsada y empujada fuera de la mesa de suministro, luego detiene el giro hacia adentro del rodillo y permite a la plataforma principal subir.

DIAGRAMA DE UBICACIÓN DE CÉLULA FOTOELÉCTRICA

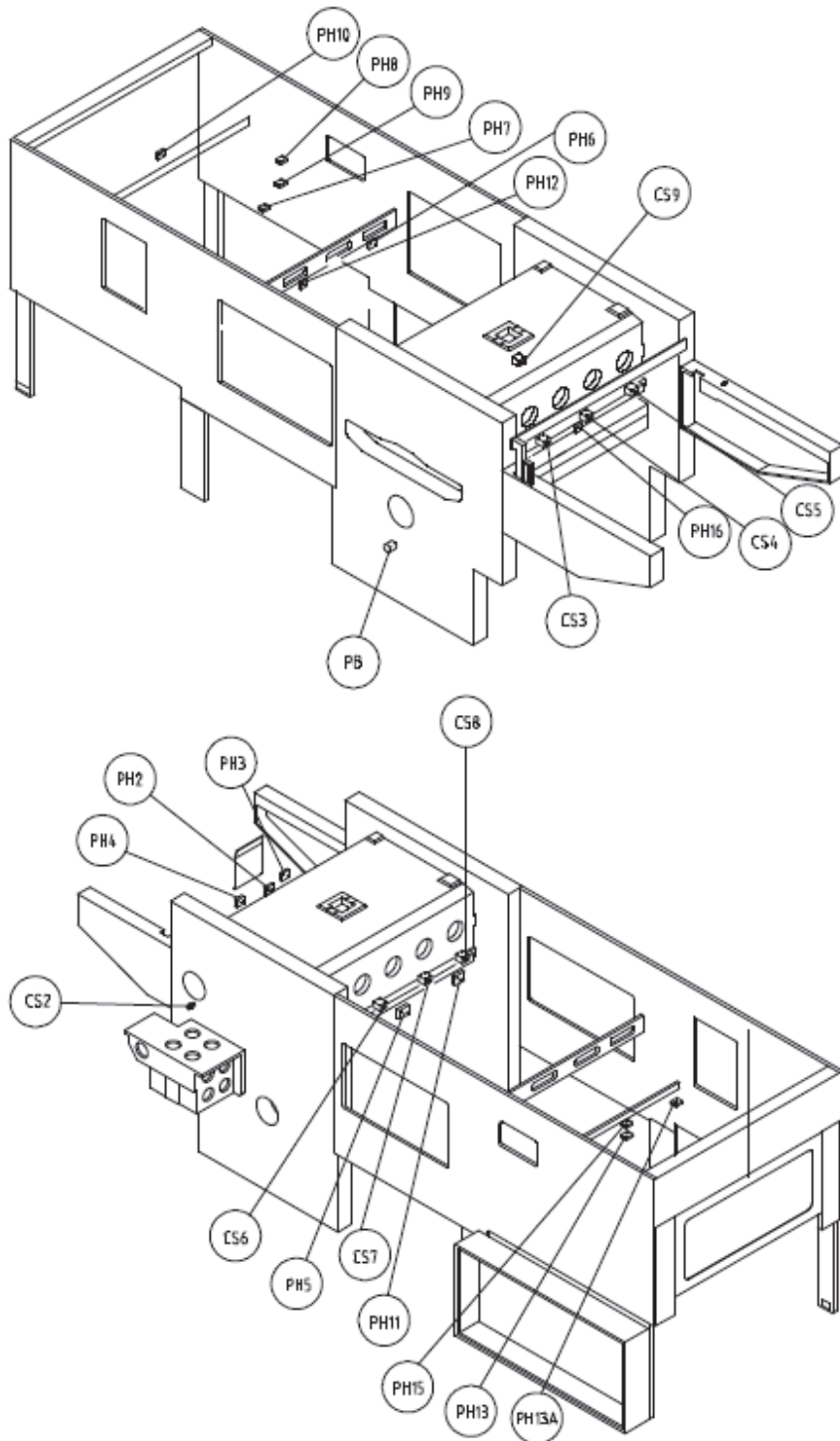

Fig. 3.1

ETERNA

INSTRUCCIONES
PE1620SA-Extra

Capítulo 4

PROTECCIONES FÍSICAS

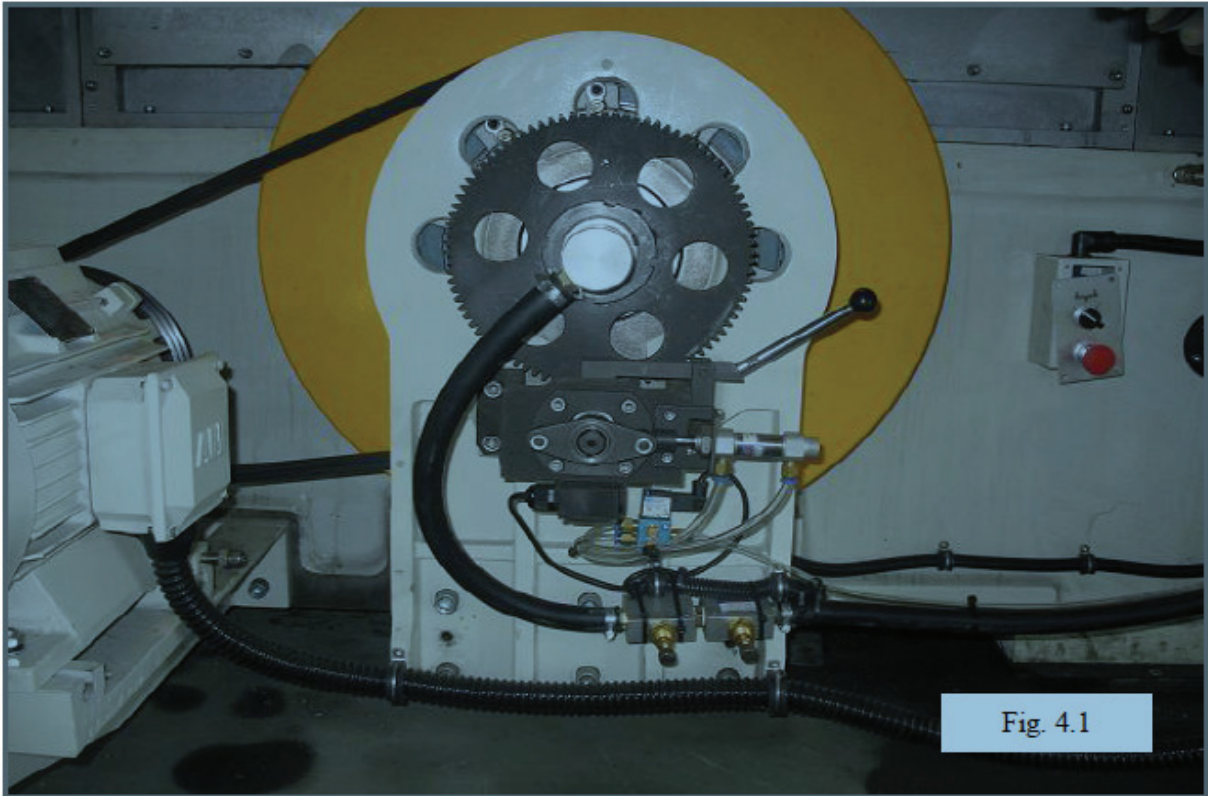

Fig. 4.1

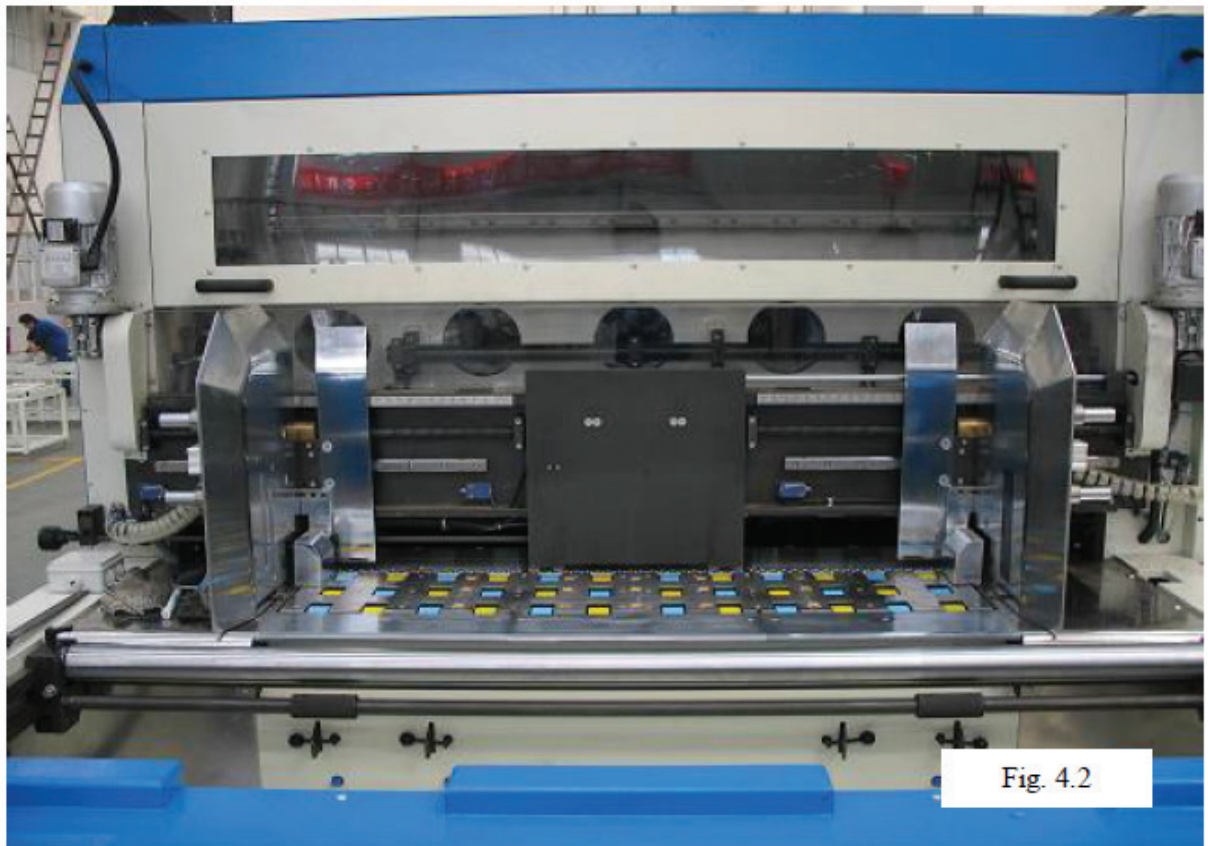

Fig. 4.2

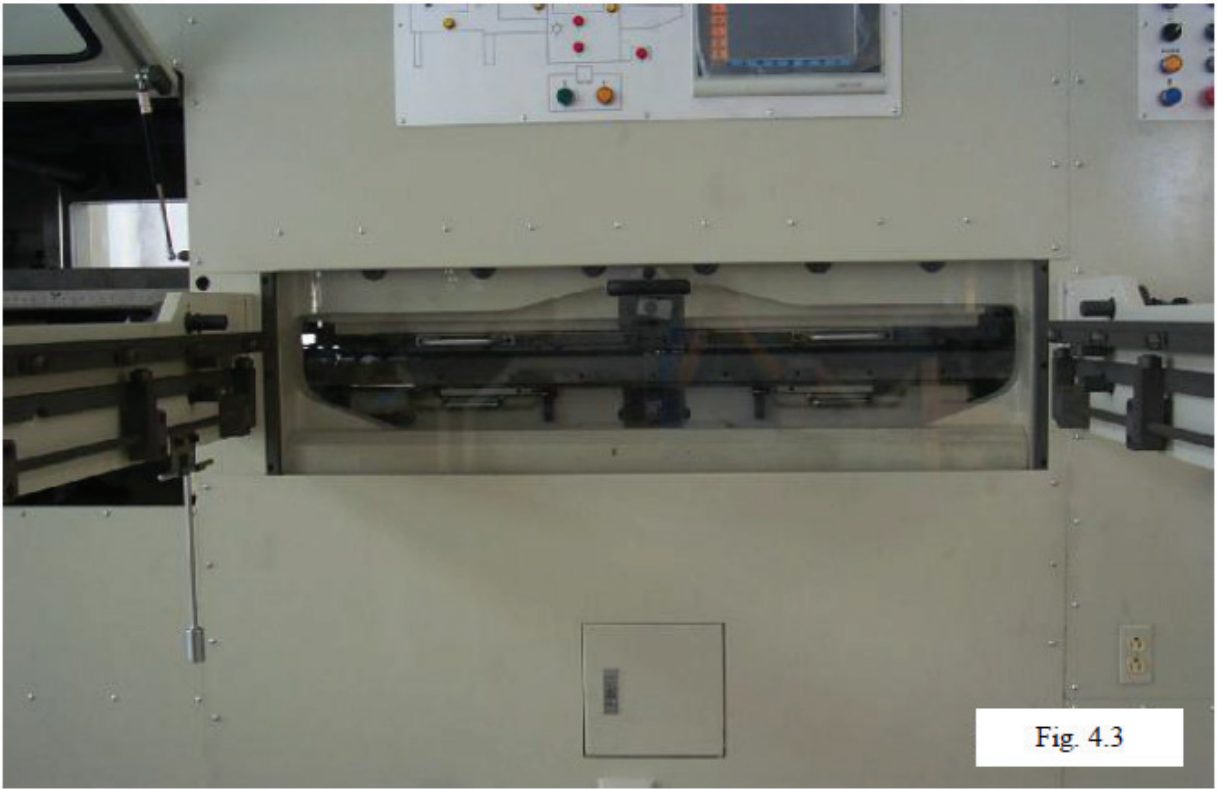

Fig. 4.3



Fig. 4.4



Fig. 4.5

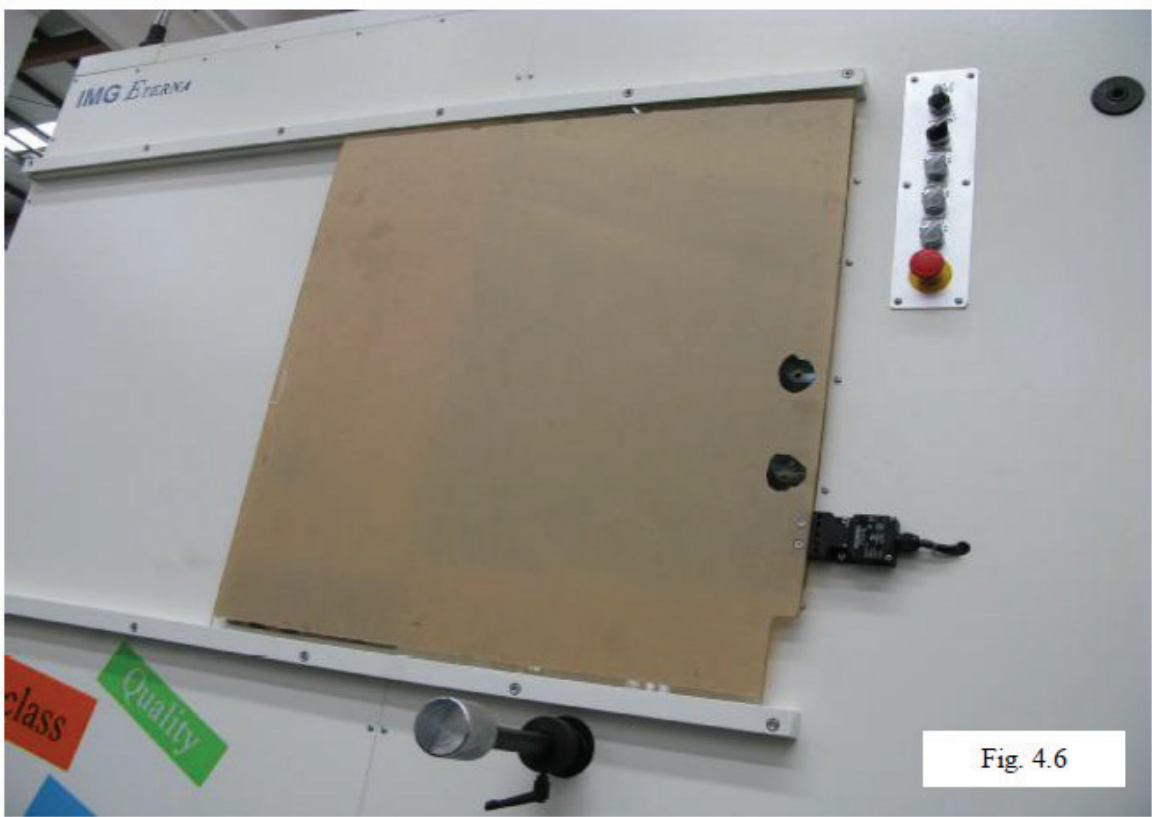

Fig. 4.6

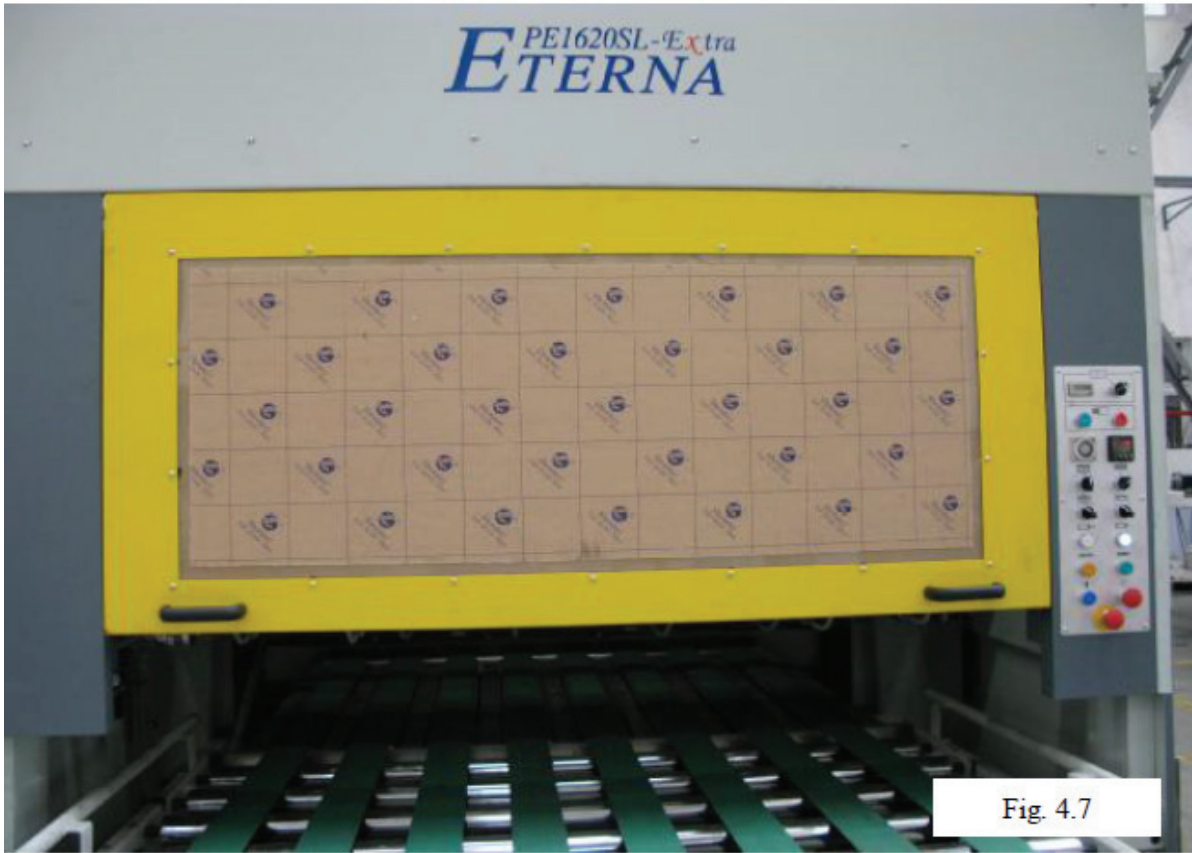

Fig. 4.7



Fig. 4.8

4. PROTECCIONES FÍSICAS

4.1. DISPOSITIVOS VARIOS DE SEGURIDAD

La máquina tiene interruptores de seguridad para el personal en las siguientes partes:

Alimentador

- Engranajes de reducción para mecanismo de accionamiento manual. (fig. 4.1)
- Puerta de entrada protegiendo el diente de engranaje en la entrada del plato de prensa (fig. 4.2)

Plato de Prensa

- Protección transparente. (fig. 4.3)

Removedor de Desperdicios

- Puerta de entrada transparente, lado del operador. (fig. 4.4)
- Puerta de seguridad del lado del mecanismo de accionamiento. (Parte alta y parte baja) (fig. 4.5)

Suministro

- Ventana transparente, Lado del operador. (fig. 4.6)
- Puerta de entrada transparente, lado del Suministro. (fig. 4.7)

Si una de estas protecciones de seguridad no está cerrada, la luz indicadora (8) se enciende y la máquina no puede ser encendida.

Si la máquina está en marcha cuando uno de estos dispositivos de seguridad está abierto, la máquina se detendrá. Importante: Es extremadamente peligroso hacer que un interruptor quede inoperativo para obtener acceso más fácil a la máquina o por cualquier otra razón. En eventos como estos, nosotros abandonamos cualquier responsabilidad.

4.2. CÓMO ENTRAR A LA MÁQUINA

Para cualquier reparación dentro de la máquina, la llave (41) debe ser retirada. Abandonamos cualquier responsabilidad en evento de accidentes debido al caso omiso que se haga a esta declaración.

4.3. DETENIDO DE EMERGENCIA

Para volver a prender la máquina después del uso del Detenido de Emergencia:

1. Restaurar el pulsador (50) de Detenido de Emergencia.
2. Poner en marcha el motor principal (pulsador 49).
3. Accionar el sensor de detección de circuito (Interruptor 48).
4. Oprimir el pulsador 44 para poner en marcha la máquina
5. Poner en marcha el Ventilador (Interruptor 25).

La máquina está equipada con un dispositivo diseñado para prevenir fallas mecánicas en caso de atasco o alta presión.

Es el dispositivo de acoplamiento para límite de torque protegiendo la unidad Indexadora. (Para restaurar dispositivo límite de torque vea la sección 2.6 del mecanismo de accionamiento manual).

ETERNA

INSTRUCCIONES
PE1620SA-Extra

Capítulo 5

ALIMENTADOR

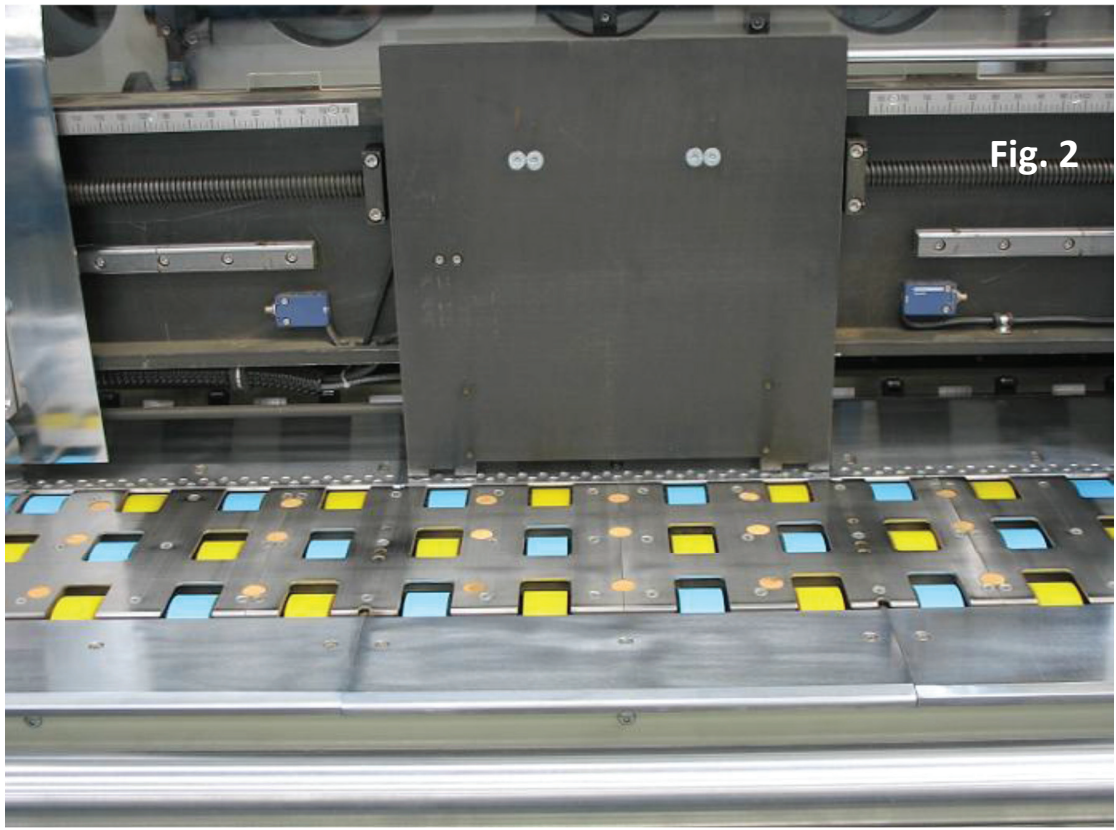

5.1. NOTA

5.1.1. LA REJILLA DE DESCENSO (Figure 1)

Descripción

La rejilla de descenso es un ensamblaje de "barrera cruzada" que está colocada para servir de cubierta a la caja de aspiración.

. Las barras de la rejilla están recubiertas para reducir la fricción entre esta y el cartón corrugado.

Función

La rejilla se alzarán y se bajarán en cada revolución de la máquina. (Dependiendo de la posición en que se encuentre la interrupción de la alimentadora y los interruptores de saltos de alimentación – Véase Sección de Control eléctrico)

Su propósito es permitir consecutivamente a cada lámina en el receptáculo estar en contacto con las ruedas de alimentación por un tiempo determinado durante el ciclo de alimentación

Cuando la rejilla esté en la posición baja, el tablero dará la alimentación hacia adelante.

Cuando la rejilla esté en la posición alta ningún tablero procederá con la alimentación.

Precauciones

1. La rejilla está nivelada en ambas direcciones dentro de 5 milésimas de una pulgada o 0.125 de un milímetro. Cualquier sobrepeso o presión innecesaria debe ser evitada, tal como apoyarse en las barras de las rejillas, ya que cualquier desviación en el nivel causará problemas con la alimentación.
2. No intente remover algún desperdicio de papel que esté atascado en la rejilla mientras la máquina esté en marcha.

5.1.2. RUEDAS DE ALIMENTACIÓN (Figura 2)

Descripción

Las ruedas de alimentación están conformadas por dos partes:

- a) La rueda núcleo (Aluminio)
- b) La banda de la rueda (Poliuretano)

El número de ruedas depende del tamaño de la máquina en la cual la alimentadora estará instalada

Función

Las ruedas de alimentación rotan en dirección hacia delante y en reversa.

En el recorrido hacia delante, una lámina será alimentada en el *front lay* de las barras sujetadoras (dependiendo de la posición en que se encuentre la interrupción de la alimentadora y los interruptores de salto de alimentación – Véase Sección de Controles Eléctricos)

Precauciones

1. No intente remover algún desperdicio de papel que esté atascado en la rejilla mientras la máquina esté en marcha.

2. En caso de que algún item esté en contacto permanente con la banda de poliuretano mientras la máquina está en marcha, este deberá ser removido cuanto antes. Si no se lo hace, causará un prematuro y forzado patrón de desgaste en la banda. Referirse a párrafo 1 antes mencionado.

5.1.3. GUÍA FRONTAL/GUÍA LATERAL (Figure 1)

Las guías frontales y laterales deberán ser instaladas en la manera estándar.

Precauciones

Las puertas de la alimentación deberán estar configuradas para permitir una lámina del tablero a la vez y no dos.

Como regla general, la guía frontal deberá estar configurada para dar 1 mm de espaciado por encima del tablero.

Esto va a prevenir que dos láminas pasen al mismo tiempo en el proceso.

5.1.4. BARRERA

Descripción

La barrera es un ensamblaje que está colocado paralelamente a los rodillos de alimentación. Es ajustable para ser compatible con distintos tamaños de tableros en la dirección que toma la alimentación.

Función

La barrera es usada para mantener el tablero en el receptáculo fijado firmemente contra la guía frontal. Si las láminas se desordenan en el receptáculo y consecuentemente se descuadran en los rodillos de alimentación, esto provocará una con dimensiones incorrectas. Es importante mantener el tablero firme, pero no tan ajustado a la guía frontal, para prevenir el descuadre de la caja final.

La barrera puede encontrarse muy cerca de la caja de aspiración o tan lejos como pueda permitirse, esto dependerá de la longitud del tablero que la máquina pueda manejar. En cualquier posición entre la distancia mínima y la máxima, la lámina puede ser alcanzada usando el volante. (Ver figura 1)

Para usar el volante, primero, afloje el dispositivo de bloqueo, gire el volante hasta que la posición deseada sea alcanzada, luego asegúrelo de nuevo una vez que la posición haya sido completada. Este dispositivo de Bloqueo, previene movimiento involuntarios durante la operación de la máquina. Un volante controla la barrera en posición vertical hacia arriba y verticalmente hacia arriba en la dirección de la alimentación; y el otro volante controla la barrera en movimiento hacia delante y en reversa.

Precauciones

1. Siempre asegúrese de que el tablero esté cuadrado en el receptáculo y use la barrera para mantenerlo fijado a la guía frontal.
2. Siempre utilice los dispositivos de bloqueo que se encuentran en el volante.
3. Asegúrese de que el área esté libre de obstáculos antes de moverla barrera en cualquier dirección.



5.1.5. SISTEMA DE VACÍO

Descripción

El sistema de vacío está compuesto por dos partes principales:

- a) La cámara de vacío
- b) El ventilador de vacío

La cámara de vacío es básicamente la caja del volante. Está dividida en secciones, cuyo número depende del tamaño de la caja del volante. Cada sección puede ser pagada usando puertas deslizables. Estas están ubicadas en el fondo de la caja del volante. Solo la sección media no puede ser apagada y está permanente abierta a succión.

El ventilador de vacío crea la fuerza de succión requerida para sostenerlas láminas firmemente contra la rejilla de descenso. Es controlada usando un interruptor eléctrico (Vea la sección de controles). La cantidad de succión es controlada cambiando la frecuencia del convertidor.

Función

Para jalar el papel corrugado uniformemente hacia la rejilla de descenso, el sistema de succión deberá proveer suficiente fuerza de succión, la cual es lo adecuado para el papel doblado.

Las puertas deslizables de vacío controlan la succión en la caja del volante, por tanto, la succión puede concentrarse en el tamaño del tablero usado en la corrida.

Las puertas deslizables deben de estar completamente hacia adentro o completamente hacia afuera.

Precauciones

1. Se debe tener precaución cuando la máquina está realizando una operación y el ventilador de vacío esté encendido. La fuerza de succión es extremadamente potente y es capaz de arrastrar hacia ella cualquier artefacto suelto hacia la cámara de vacío. Herramientas y otros artefactos pueden dañar el impulsor.
2. Asegúrese de que los conductos y el sistema de recolección de polvo estén limpios, ya que cualquier bloqueo causará un deterioro en la eficiencia de la máquina.



Fig. 4

5.1.6. CONTROLES ELÉCTRICOS (Figura 1)

Descripción

Hay una pequeña cantidad de controles eléctricos asociados con el Primtec Accu-Feed.

b) Interruptor de Alimentación eléctrica

c) Salto de alimentación

Todos estos están claramente identificados en la estación de control de los interruptores.

5.1.7. INTERRUPTOR DEL MOTOR DEL VENTILADOR (VENTILADOR DE VACÍO) (INTERRUPTOR DE DOS POSICIONES)

Este interruptor pondrá en marcha el motor del ventilador cuando está en la posición **1** y detendrá el ventilador cuando esté en la posición **0**

5.1.8. INTERRUPTOR DE INTERRUPCIÓN DE ALIMENTACIÓN (HALAR/EMPUJAR) (Figura 1)

Coloque interruptor 26 en la posición 1 para iniciar el suministro de papel; y hale el interruptor a la posición 0 para detenerlo.

Proceso para iniciar la operación.

- 1) Obtenga una muestra del cartón para realizar la corrida.
- 2) Usando el dato de la máquina, ajuste las compuertas de alimentación en su posición y altura correspondientes para el tamaño de la lámina a usarse en la corrida.
- 3) Usando el dato de la máquina, ajuste las guías laterales al tamaño aproximado de la lámina a usarse en la corrida.
- 4) Usando una lámina del tablero para hacer la corrida, colóquela en el alimentador contra las compuertas de alimentación y coloque la barrera para mantener las láminas firmes pero no muy pegadas a las compuertas de alimentación.
- 5) Ajuste las puertas deslizables de vacío al ancho apropiado para la lámina.
- 6) Cuando esté listo para realizar la corrida, encienda el motor del ventilador y espere aproximadamente 30 segundos para que el nivel de succión se estabilice.
- 7) Cuando esté listo para poner el cartón en el suministro, encienda el Bloqueo de Suministro para permitir que las láminas sean suministradas al rodillo prensador de la máquina.
- 8) Una Belly Bar puede ser usada cuando se quiera realizar una corrida de cartones largos y pesados que tiendan a meterse en la región sin apoyo entre la Barrera y la cámara de vacío.

5.2. GUÍA DE SEGURIDAD Y OPERACIÓN

Bloqueo de Alimentación

1. Siempre detenga el ciclo de alimentación (Bloqueo de alimentación) previo al detenido de la máquina. Esto previene uso indebido del mecanismo de descenso de la rejilla y detiene el movimiento de la rejilla cuando no hay cartón presente.
2. Intente detener el ciclo de alimentación (Bloqueo de Alimentación) tan pronto como sea posible luego de que l última lámina haya sido suministrada, luego haga que la máquina se detenga paulatinamente.

Altura de la Pila

1. La altura de la pila de cartón en el alimentador, deberá estar ajustada a un nivel razonable, dependiendo de la calidad del cartón. Generalmente, el nivel deberá permanecer en la altura siguiente:-
2. Trate de colocar el cartón en el receptáculo y no de tirarlo en la bandeja. Esto puede causar una mala alimentación al momento de impactar las láminas en la bandeja.
3. No coloque objeto pesado alguno en la rejilla de alimentación. Esto puede distorsionar las barras de la rejilla y provocar una alimentación deficiente.

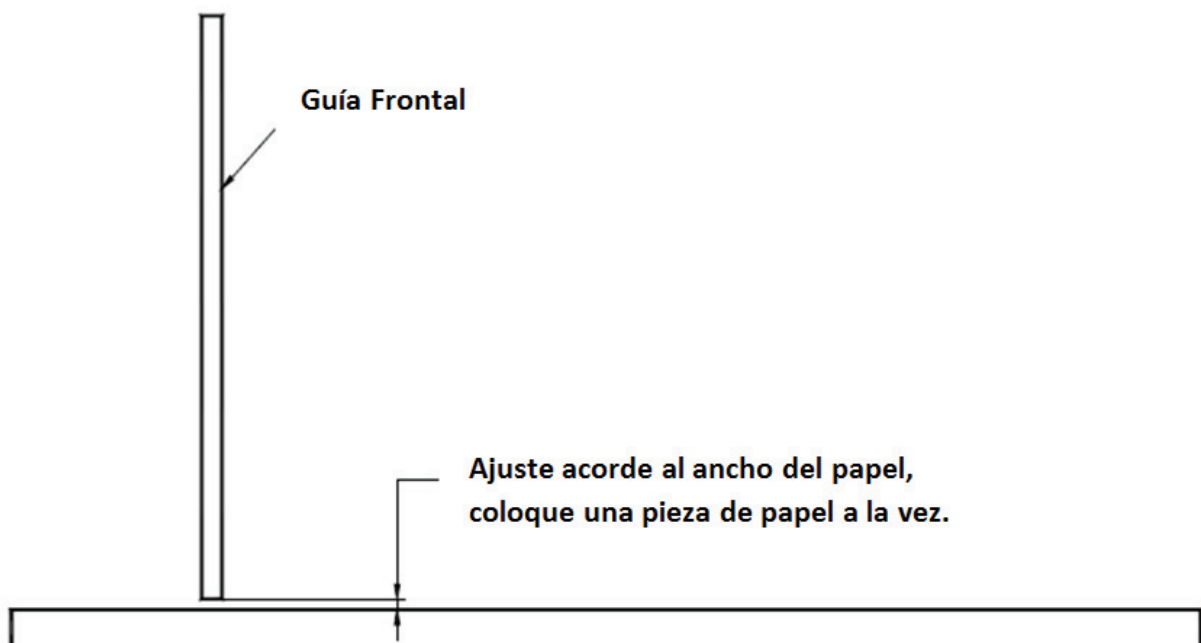

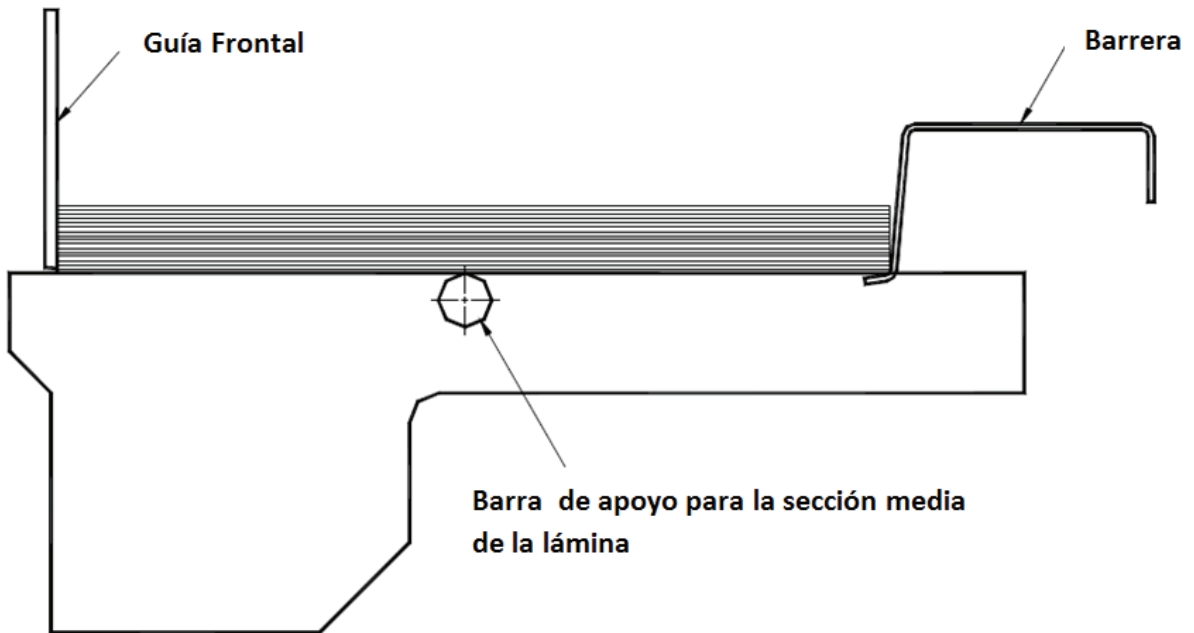
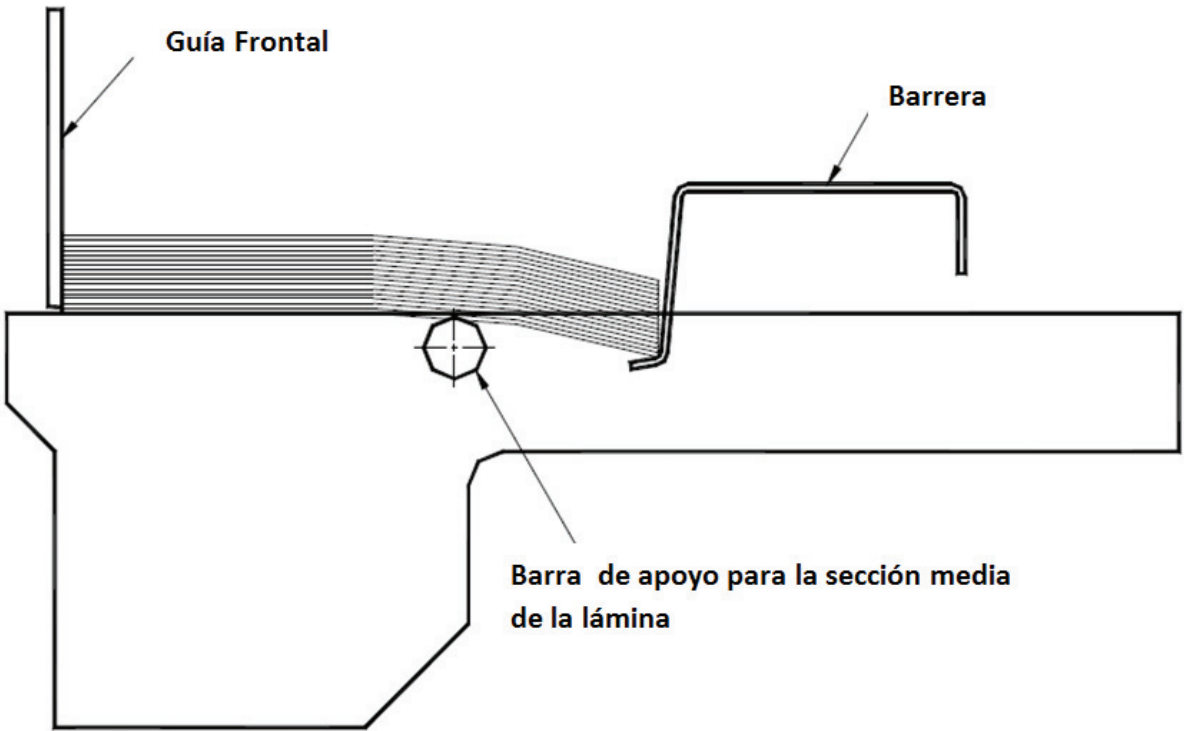

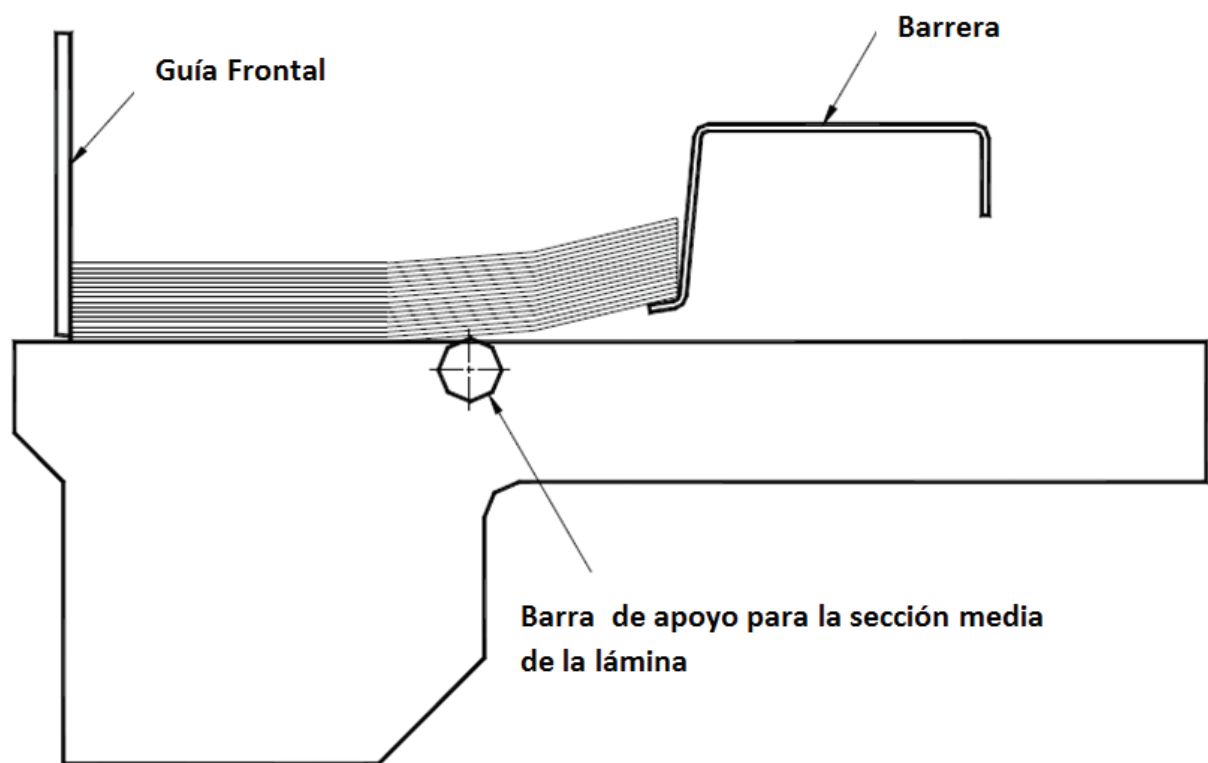
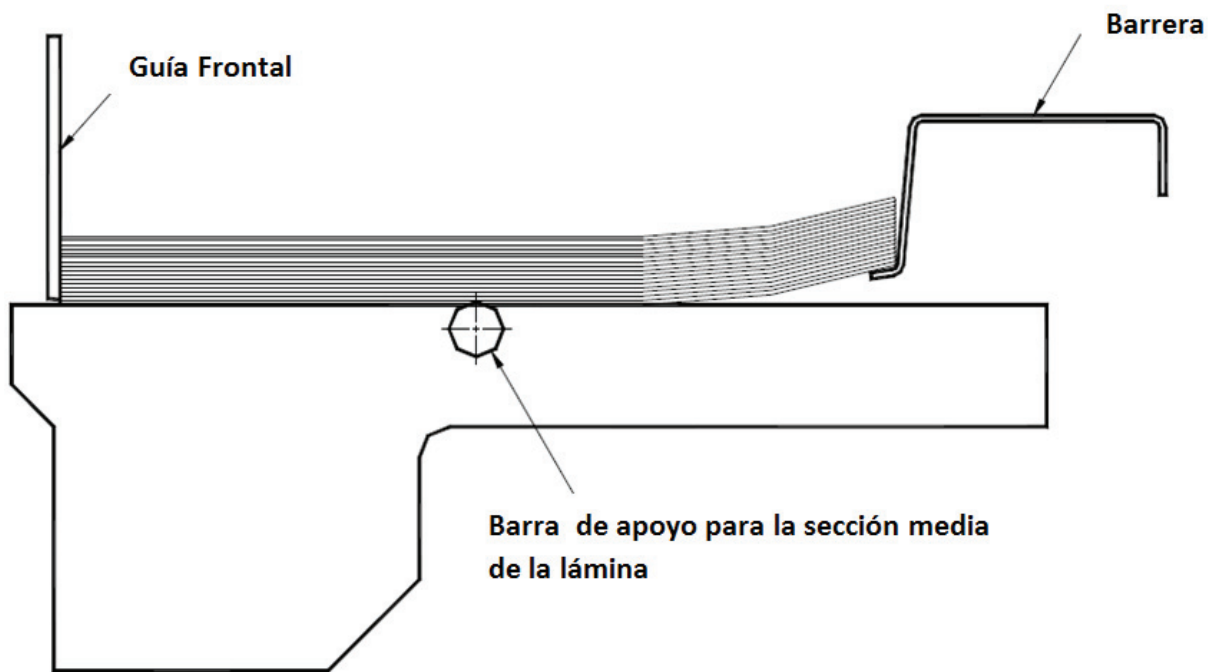

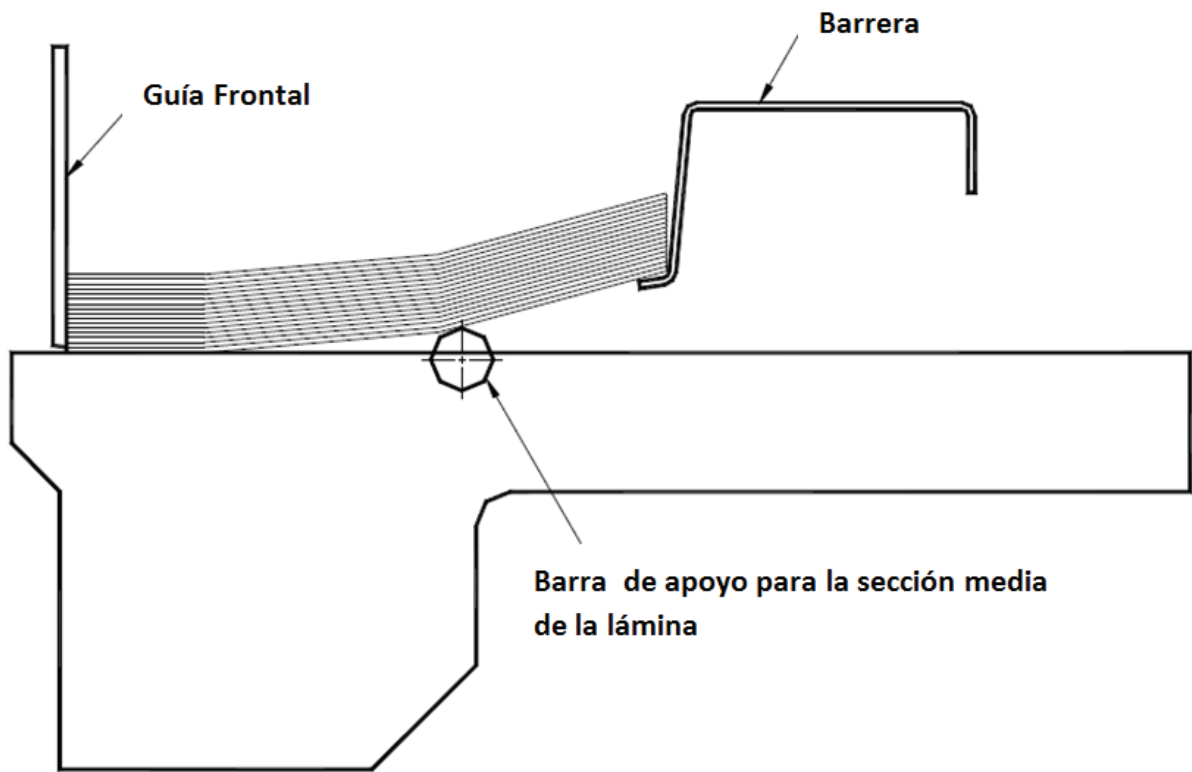

5.3. MANTENIMIENTO

5.3.1. Limpieza

1. Limpie el polvo del alimentador tras cada corrida.
2. Limpie el polvo de la cámara de succión tras cada corrida.

Realice esto una vez por semana.

1. Lubrique el soporte de la vara (Use una gota).
2. Lubrique todos los puntos de lubricación que la requieran.

Una vez al mes (Remueva los dispositivos de seguridad de cada lado.)

1. Rote el rodillo de suministro
2. Revise las partes desgaste en el área de la leva
3. Revise la barrera
 - a) Remueva todas las protecciones de seguridad y lubrique todos los engranajes de la barrera.
 - b) Revise si la barrera opera con normalidad.

Una vez al año

1. Revise el rodillo para evitar desgaste excesivo.
2. Remueva y limpie la puerta de cierre de vacío y el propulsor.

3. Reemplace el aceite en la caja de engranaje.
4. Revise la toma eléctrica y sus conexiones.
5. Revise la rejilla de descenso para asegurarse de que está
 - a) Estable
 - b) Sin daño alguno.

5.3.2. Recomendaciones para Lubricación

Descripción	Lubricación	Intervalo
Contenedor de la transmission	Lubricante Shell 634 para Engranajes	Deseche el desperdicio de aceite, limpie y reemplace con aceite nuevo.
Apoyo	NLGI Grado 2	Semanalmente
Caja de Leva	NLGI Grado 2	Semanalmente
Apoyos de control Sellados	NLGI Grado 2	Semanalmente
Vara de entrada	NLGI Grado 2 (en la cubierta)	Embalaje del manguito con lubricante
Bisagra Universal	Aceite ligero en el pin central	
Manguera de Aire	No. 10	Manténgalo lleno

CONSEJOS PARA RESOLUCIÓN DE PROBLEMAS

Situaciones	Posibles Causas	Soluciones
ALIMENTACIÓN ERRÓNEA (LAS LÁMINAS AVANZAN, PERO NO DE MODO CONSTANTE)	Ventilador de Vacío no está corriendo	Encender el ventilador
	Rotación del ventilador de vacío (Vacío insuficiente)	Chequear la correcta rotación en carcasa del ventilador
	Ajuste de la Barrera	Ver guía de instalación
	Altura de la pila está muy alta	Reducir la altura de la pila para reducir el peso
	Presión del rodillo de alimentación	Ajústelo al calibre del cartón
	Nivelación de rejilla	Ver procedimiento para la rejilla niveladora
	Mecanismo gastado o dañado	Revisar el mecanismo de leva y componentes de la conexión "hueso de perro" en busca de aperturas excesivas que puedan causar desgaste.
DESVIACIÓN (LÁMINA AVANZA, PERO LA IMPRESIÓN Y TROQUELADA NO SON PERPENDICULARES)	Ventilador de vacío no está funcionando	Encienda el ventilador
	Rotación del ventilador de vacío (Vacío insuficiente)	Chequear la correcta rotación en carcasa del ventilador
	Distancia errónea de suministro de papel	Ajuste la posición del cigüeñal excéntrico PA2014. Para que detenga el papel cuando acabe de alcanzar la Posición frontal
	Vacío no distribuido	Refiérase a la guía de instalación
	Compuertas de alimentación no están alineadas	Reajustar las compuertas de alimentación para que estén a la par.
SALTO DE ALIMENTACIÓN/BLOQUEO DE ALIMENTACIÓN NO ESTÁ FUNCIONANDO	No hay suministro de entrada de aire	Revisar líneas de entrada en busca de fugas, etc
	La presión de aire no está configurada apropiadamente	Colocar el regulador en 50-60 psi

ETERNA

INSTRUCCIONES
PE1620SA-Extra

Capítulo 6

TROQUELADORA

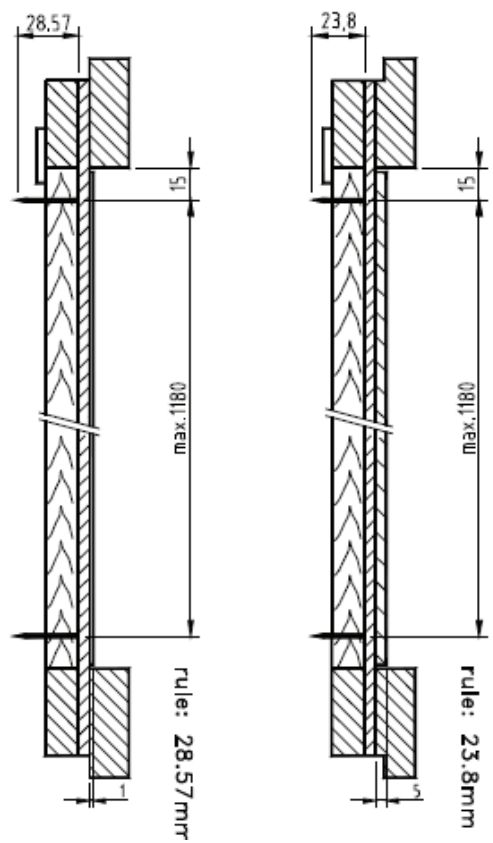
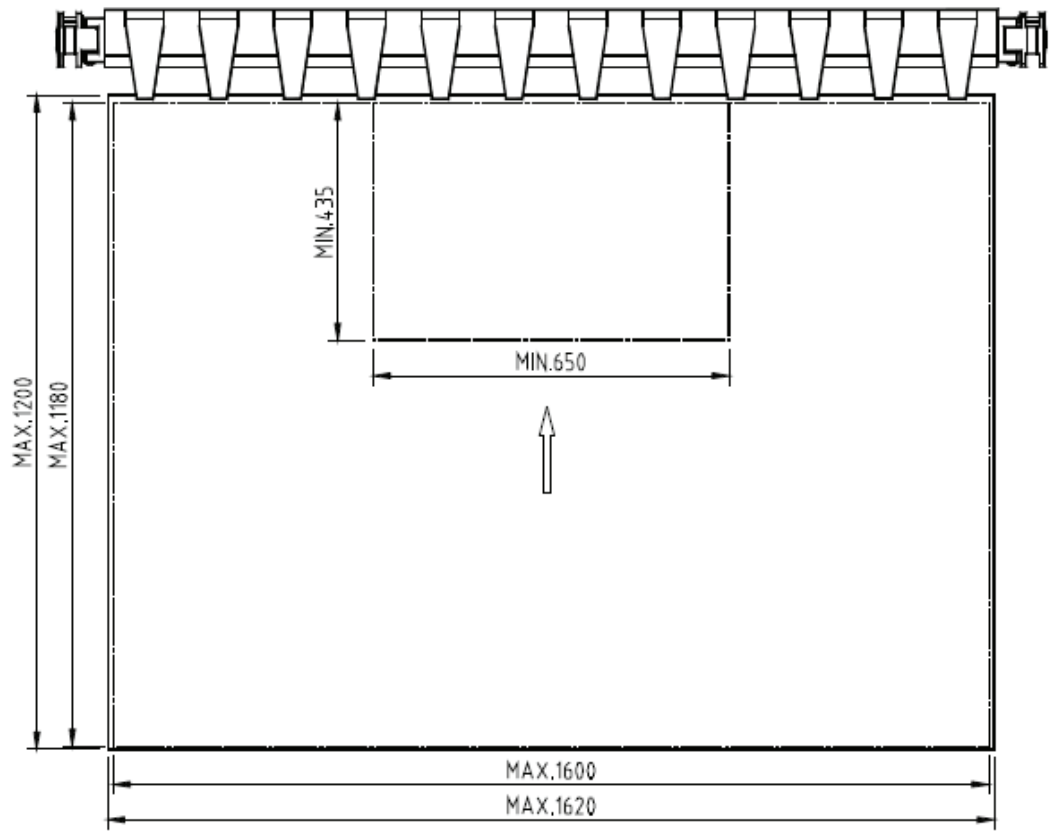

Fig. 6.1

6 TROQUELADORA

6.1 DESCRIPCIÓN GENERAL

6.1.1 Operaciones Generales (Fig. 6.1)

El troquel está ubicado e incrustado en el plato superior

La placa para corte está en el fondo, y localizado en el plato movable.

La fuerza de corte es regulada por una manivela (Fig 6.2) cambiando de lugar los espaciadores cónicos localizados debajo de los manguitos.

6.1.2 Ajustando la mesa superior para troqueles

La mesa para troqueles superior está suspendida por 7 agarraderas operadas por cilindros de resorte accionados asegurando el pulsador (20)

6.2 CONTROL DE LA FUERZA DE CORTE

6.2.1 Descripción (Fig. 6.2)

Manivela para Control de Fuerza

Gire a la Derecha para incrementar la fuerza

Gire a la Izquierda para reducir la Fuerza

Importante: La fuerza puede ser ajustada mientras la máquina está en operación o cuando está detenida.

6.2.2 Fuerza de Corte e Incremento de temperatura de la máquina

Con un determinado ajuste, al fuerza de corte tiene a incrementar a medida que la máquina se inicializa.

Mantenga la fuerza constante usando la manivela.

6.3 PLACA ASEGURADA BAJO PRESIÓN

La placa deberá ser asegurada bajo presión en los siguientes casos:

- Un detenido de emergencia (50) ha sido presionado
- Uno de los interruptores para seguridad de personal ha sido accionado.
- Se aplica demasiada presión
- Falla eléctrica

Eliminación de problema

Si la máquina está asegurada bajo presión, proceda como se indica a continuación.

Intente liberar la placa mediante la marcha intermitente. SI el embrague se zafa luego de que el botón para marcha intermitente ha sido presionado por unos segundos, no insista, y muévelo manualmente.

Vea sección 2.6 para Accionamiento Manual

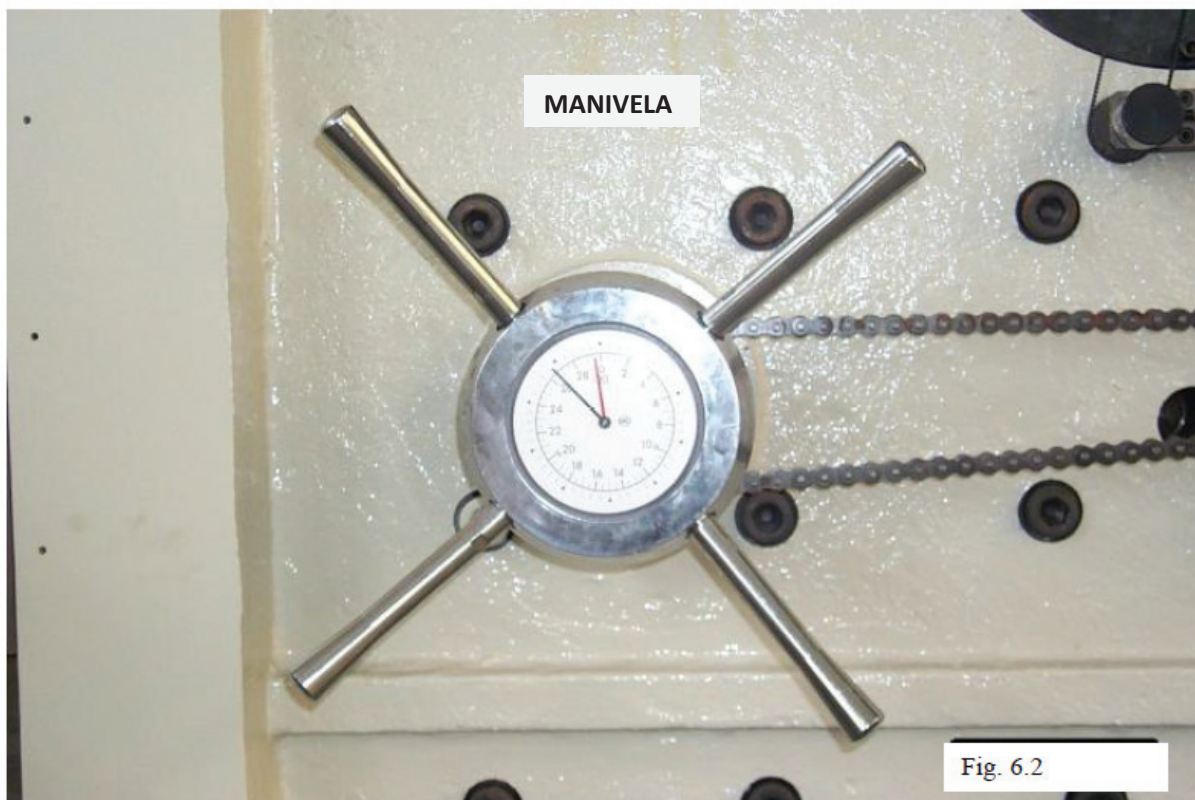

6.4 DESCRIPCIÓN DEL EQUIPO DE TROQUEL Y MATERIALES

6.4.1 General

La máquina fue diseñada para:

- Para reglas de corte de 23.8 mm o 28.57 mm. Para cartones de hasta 9 mm de espesor.

6.4.2 Mesa para troquel para Regla de 23.8 mm o Regla de 28.57 mm

Ver Fig. 6.3

Indicado para cartones sólidos y corrugados de hasta 9 mm de espesor.

Para usarse en reglas de 28.57mm, para reemplazar las agarraderas de los rieles de ambos lados de la mesa para troquel. (fig. 6.3)

6.4.3 Troqueles Cortadores

Madera: Plywood Duro, de 8 a 12 capas, grosor: 15 mm.

Caucho: Para extenderse más allá de las reglas de corte por 2 mm.

Reglas cortadoras: - 2 or 3 puntos para cada 23.8 mm.

- 3 puntos para cada 28.57 mm.

Usar doble-biselado preferiblemente (fig. 6.5): esto facilita la penetración

Reglas de Dobleces

Grosor recomendado para cartón corrugado E: 3 puntos.

Grosor recomendado para cartón corrugado A, B y C: 3 o 4 puntos.

Acotación: Buenos resultados han sido obtenidos con reglas de 3mm en dirección transversal de las corrugaciones.

Con cartón de doble pared, 2 reglas de dobleces, pueden ser usadas como se muestra en figuras 6.6 & 6.7.

Altura: A ser determinada de acuerdo a fig. 6.6 & 6.7.

Dimensiones del Troquel

Por motivos de ajustar la mesa para troqueles, troqueles grandes dimensiones deben ser cortados en su mayor dimensión, eso quiere decir:

Ancho en exceso de 1600 mm: ancho del troquel: 1630 mm.

Largo en exceso de 1180 mm: largo del troquel: 1215 mm.

Intercambiabilidad de troqueles

Troqueles cortadores para reglas cortadoras de 23.8 mm alistadas de acuerdo a 6.4.3 pueden encajar en PE1620SA-Extra.

6.5 ENCAJANDO EL TROQUEL EN LA MESA PARA TROQUELES

6.5.1 Posición del Troquel

Longitudinalmente, el troquel está siempre montado contra el borde frontal del cuadro (Véase Fig. 6.4).

Lateralmente, el troquel debe normalmente de estar centrado en la mesa para troqueles.



Fig. 6.3

Rieles de agarraderas a ambos lados de la mesa usando la regla para troquel de 28.57 mm



Fig. 6.4

Troqueles cortadores y mesa par troquel

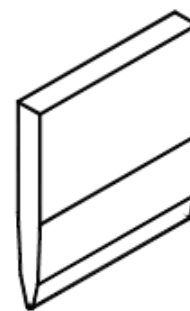
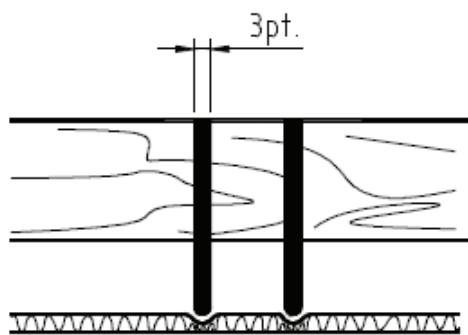
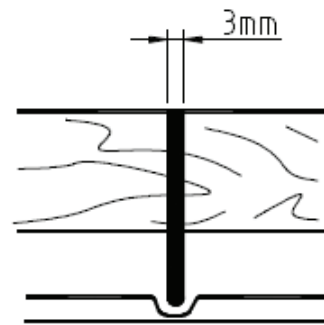
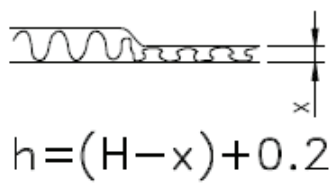
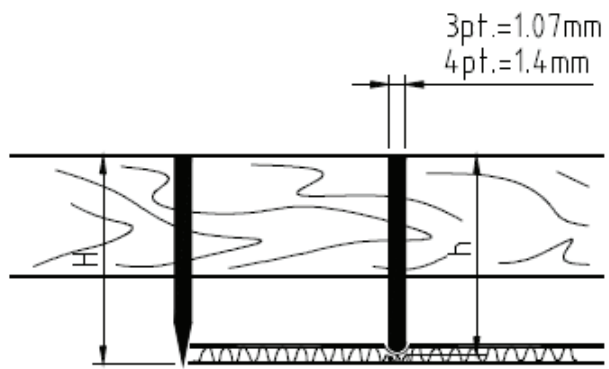
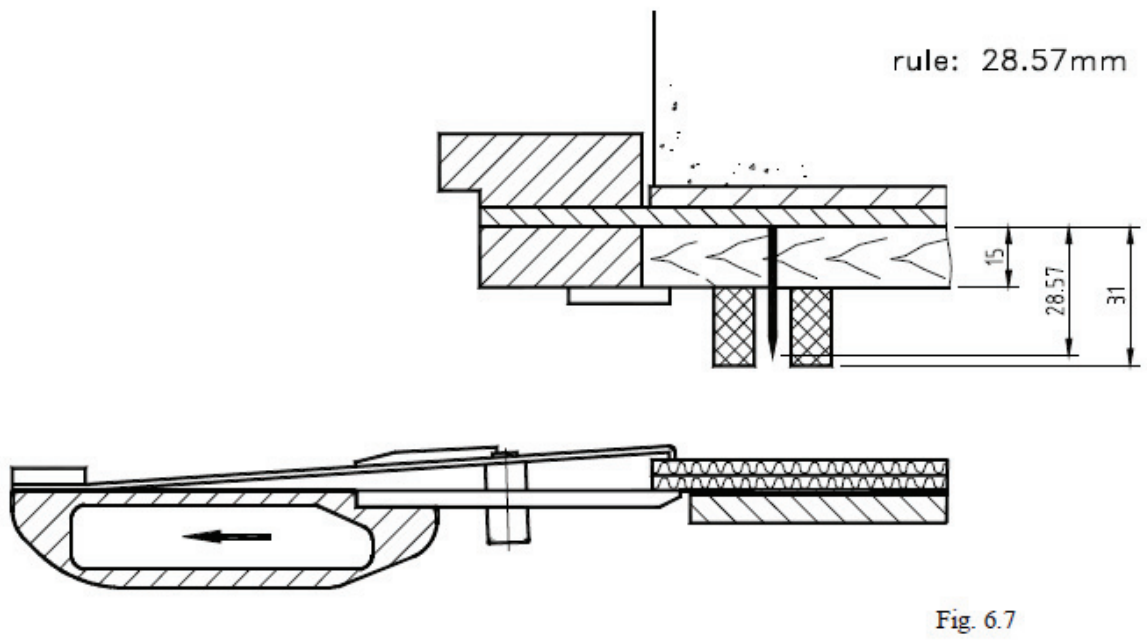
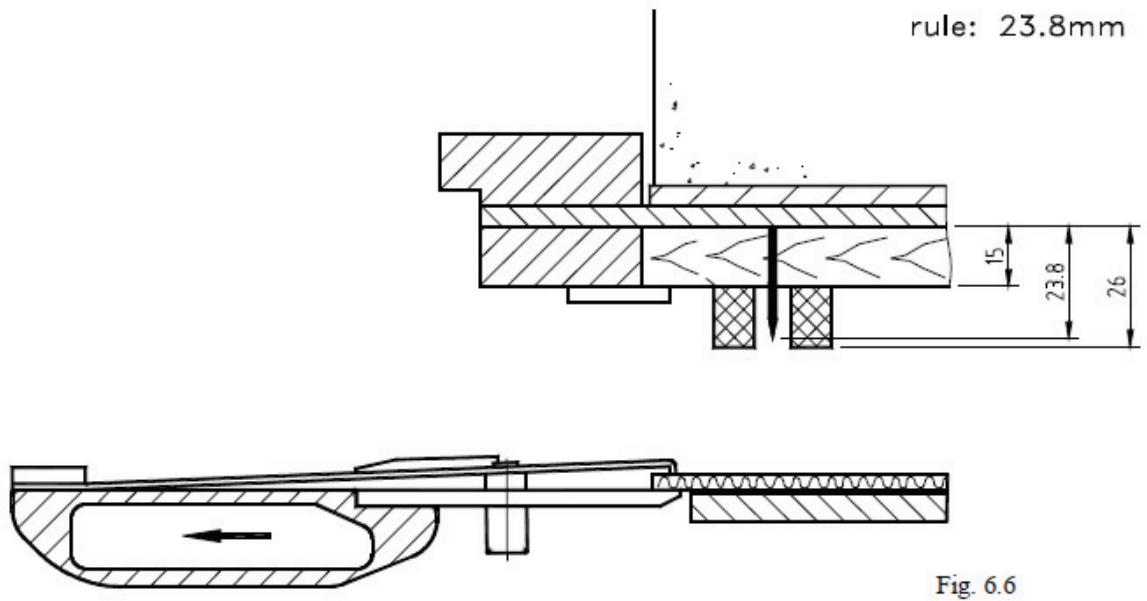

Fig. 6.5



6.5.2 Tornillos de Seguridad

La placa del fondo tiene huecos para los tornillos usados para asegurar el troquel al chase. Tal como se muestra en la fig. 6.8, así como también la clase de tornillos apropiados para su uso.

El gráfico al final del capítulo 6 muestra todas las posibles ubicaciones para estos huecos. Noción de esto se debe tener en caso de que los huecos sean hechos con antelación fuera de la mesa para troquel (fig. 6.16)

6.5.3 Balanceo de la mesa para troquel

Si el troquel es menor a 900 mm en tamaño, ensamble un troquel de compensación con unas reglas de corte tal como se muestra en la fig. 6.10, para proporcionar balance a la placa.

6.6 MANEJO DE EQUIPO DE TROQUELADO

6.6.1 Cómo poner mesa para troquel de vuelta en su lugar

1. Coloque la placa en posición baja – Abra la protección transparente.
2. Levante la mesa para troquel con un elevador usando los mangos apropiados y colóquelos en el brazo de apoyo de la mesa para troquel
3. Engrane los dos tornillos pivotes
4. Saque el mango de elevación
5. Vire la mesa para troquel boca arriba y agárrelos usando los alfileres de seguridad para dedos que se encuentran en ambos lados.
6. Monte el troquel de corte.
7. Voltee la mesa para troquel
8. Libere los alfileres de seguridad
9. Empuje la mesa de troquelado completamente en la sección de corte.
10. Oprima el pulsador # 20.
11. Cierre el candado de seguridad

6.6.2 Cómo sacar la mesa para troquel

1. Coloque la placa en la posición más baja – abra la protección transparente.
2. Oprima el botón 20 para desbloquear
3. Abra el candado de seguridad
4. Saque la mesa para troquel

6.6.3 Cómo remover el plato de corte (fig. 6.10)

1. Oprima el pulsador 21 para mover la barra sujetadora a la posición de 180.
2. Abra la protección transparente



Tornillo usado para asegurar el troquel a la mesa para troquel



Mesa de troquelado y brazo de soporte

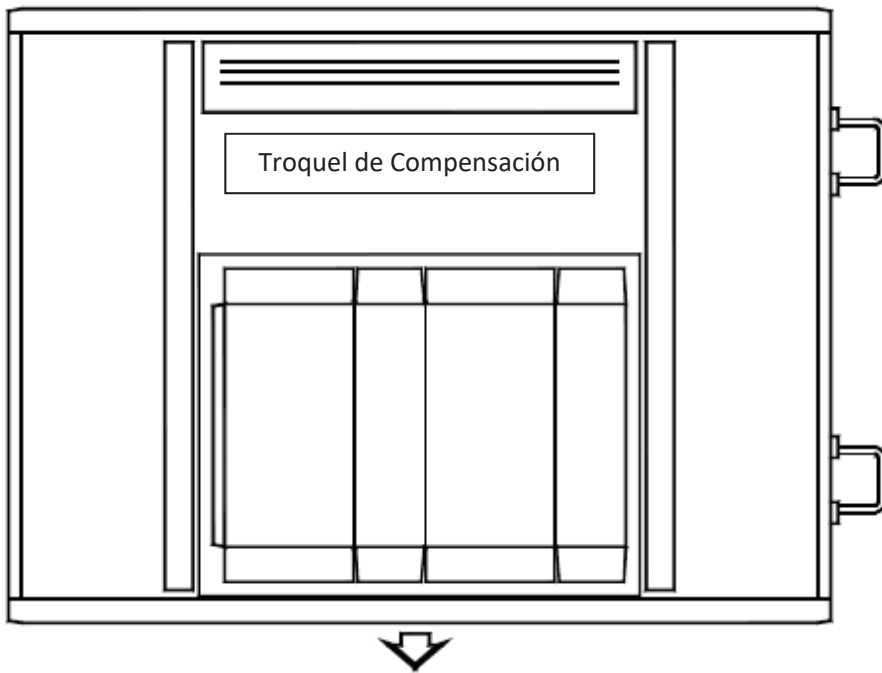
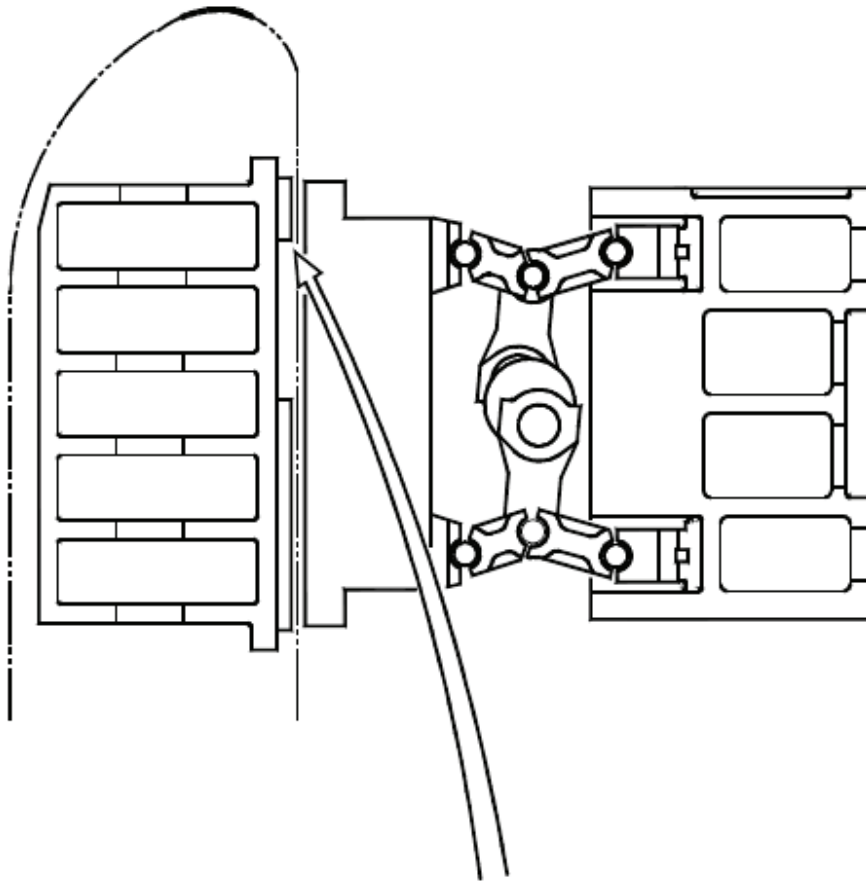

3. Abra el candado de seguridad (fig. 6.17)
4. Voltee ambos platos de corte sosteniendo el riel en el brazo de apoyo, y levante la palanca para encendido o apagado del cojín amortiguador (fig. 6.9).
5. Saque la placa cortadora.

6.7 PROCESO DE "PREPARACIÓN DE LA FORMA"

Cualquier trabajo de corte requiere un preciso ajuste de altura de las reglas cortadoras de acuerdo con el resultado de la primera prueba de corte, cuando cerca del 80% de los patrones de cortes son cortados correctamente.

Este ajuste es conocido como "Preparación de la forma // Make-ready // Makeready", y es llevado a cabo con papel adhesivo para ser pegado en la parte de atrás de la placa para la preparación de la forma. Dos rodillos de papel de este tipo de distinto espesor son provistos con el equipo, por ejemplo: 0.04 mm y 0.1 mm (0.0016 y 0.004). Para poder pegar las tiras en la ubicación correcta, e.g. Cuando el corte es muy débil, es necesario usar una lámina preliminar de preparación, en la cual el delineado de las reglas de corte está marcado. La lámina de preparación de la forma debe ser de papel de embalaje y puede ser preparada en distintas formas, algunas de las cuales son mencionadas a continuación:

- a) Lámina para preparación de la forma preparada por el marcador de troquel cuando se crea el troquel. Antes de encajar la goma, es fácil transferir el delineado de las reglas de corte mediante papel carbón.
- b) Lámina para preparación de la forma preparada por el operador de una lámina troquelada la cual es usada como patrón para delinear las reglas de corte
- c) La lámina de preparación de la forma puede ser preparada por el operador, mediante transferencia de papel carbón dentro de la máquina.

Prosiga de la siguiente manera:

1. Configure la fuerza de corte a 5 o 10 toneladas girando la rueda de ajuste de presión de corte.
2. Ponga los siguientes materiales en la placa cortadora.
 - una lámina para la preparación de la forma
 - papel carbón, con el recubierto hacia abajo.
 - un cartón fino
3. Opere la prensa una vez. La lámina para preparación de la forma contiene las marcas de las reglas de corte y pueden ser usadas como se describió en pasos anteriores.

Posición de la lámina para preparación de la forma

Para ajustar la lámina para la preparación de la forma con las reglas de corte, revise la distancia entre el borde del marco y las reglas de corte y posicione la lámina adecuadamente, Asegure la lámina para la preparación de la forma a las esquinas usando papel adhesivo.

6.8 CONTRAPARTES DE DOBLECES

6.8.1 Trabajar sin la contraparte

La mayoría de trabajos son llevados a cabo sin la utilización de la contraparte para dobleces. El cartón es simplemente aplastado contra la placa de doblez. Esto no es apropiado para cartón sólido.

6.8.2 Trabajando con Contrapartes

Las contrapartes para los dobleces son:

- Esenciales para cartón sólido
- Necesario para el corrugado E flauta.
- recomendado para cajas de producción con corrugado de B flauta para ser transferidas a las máquinas empalmadoras (foldergluers)

Especialmente para los siguientes tipos de cajas (fig. 6.12-fig. 6.13).

- con dispositivo de seguro de choque en el fondo (A).
- Con 4-6 esquinas engomadas (B).

6.8.3 Producción de las Contraparte

Sistema de “Canal”

Este sistema consiste en tiras compuestas de una guía plástica y su complemento, el cual es auto adherible. (fig. 6.14).

Estas tiras deben ser cortadas de la longitud de las reglas para dobleces y fijadas a estas. (fig. 6.11).

Después de todo, todo lo que se tiene que hacer es remover el papel protector y luego introducir el troquel y la placa de corte en la máquina y operar la prensa una vez (B).

Las guías plásticas y las tiras adhesivas pueden entonces ser removidas y la producción puede comenzar (CD).

Ventajas del método:

Rápido y fácil de usar, el sistema no requiere una impresión del troquel.

Para las dimensiones de acuerdo al tipo de cartón, consulte al fabricante.

Otro Sistema:

Las contrapartes pueden ser hechas de cartón prensado (fig. 6.15) pegados a un aplaca de corte. Esto requiere la impresión de un troquel de corte, para ser realizada con papel carbón aplicado directamente a la placa de corte.

Proceda de la siguiente manera:

Ponga los siguientes materiales en la placa de corte: Un papel carbón, con el revestimiento hacia abajo;
Un cartón ligeramente más grueso que la diferencia existente entre las reglas de corte y los plegadores.

Opere la prensa una vez. El diseño obtenido en la placa hace posible dar forma al cartón prensado.

El grosor del cartón prensado y el ancho de las muestras, dependen del grosor de las capas de corrugado y no puede ser definido teóricamente.

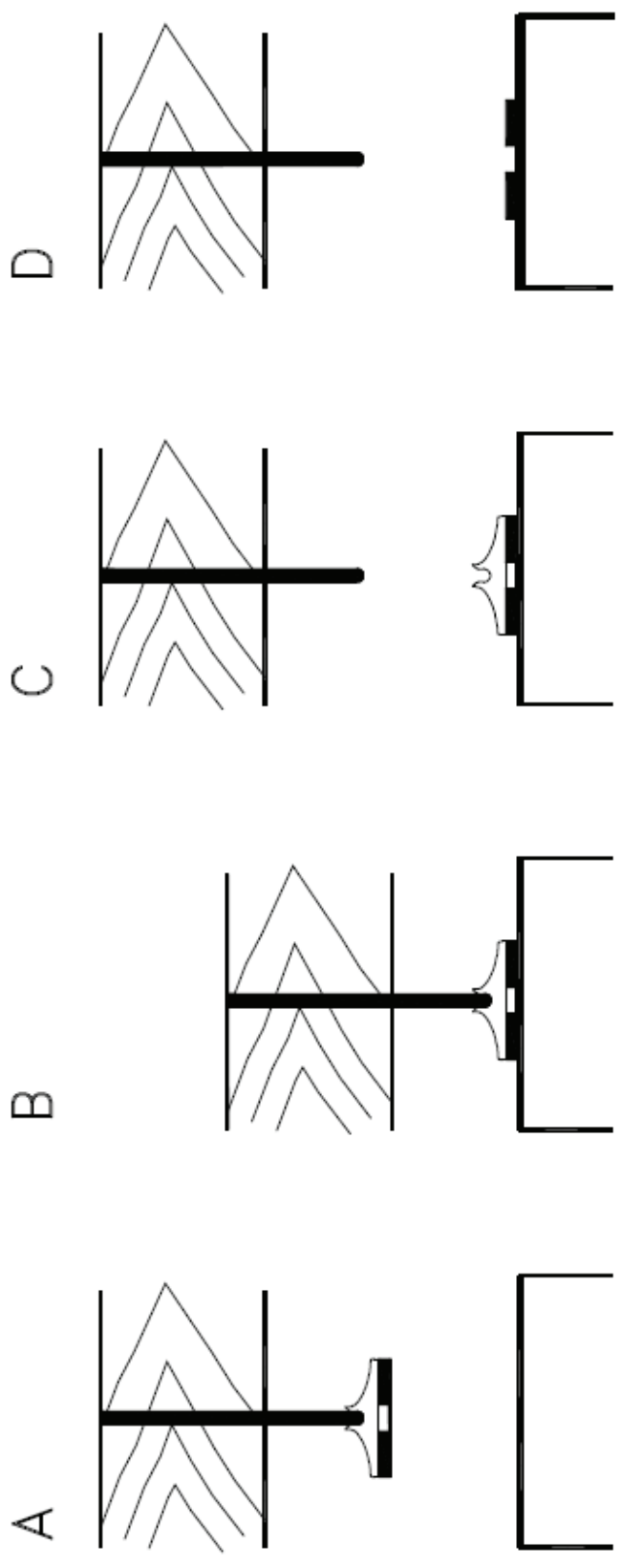

Fig. 6.II
Contador de Pliegues

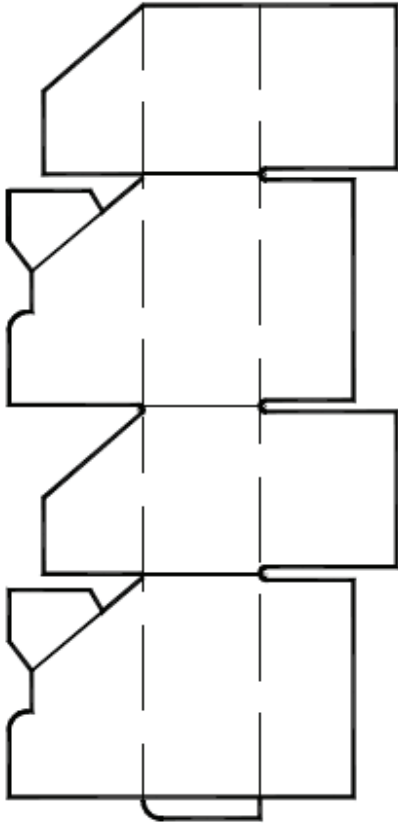

Fig. 6.12

A. Caja con seguro de choque en el fondo



Fig. 6.14

Contraparte Sistema de "Canal"

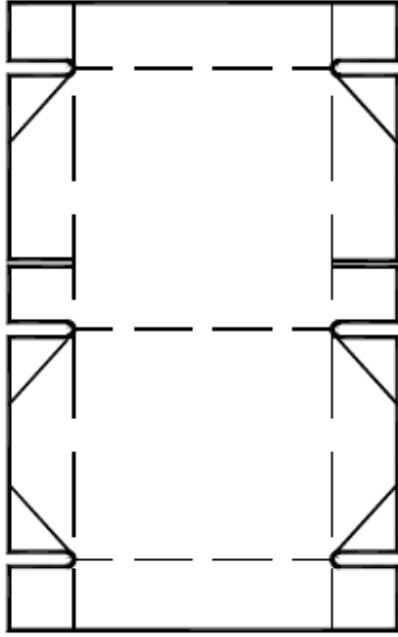

Fig. 6.13

B. 4-6 Caja con esquinas engomadas



Fig. 6.15

Contraparte hecha de cartón



Diagrama de patrón para posibles ubicaciones de huecos de tornillos .Fig.6.16

PE1620SA-Extra

N*	X	Y	N*	X	Y	N*	X	Y
1	-649.5	102.4	35	75	347.5	69	594.6	647.5
2	-724.5	232.3	36	0	477.4	70	519.6	774.4
3	-799.5	362.2	37	-75	607.3	71	444.6	907.3
4	-444.6	47.5	38	-150	737.2	72	369.6	1037.2
5	-519.6	177.4	39	-225	867.1	73	294.6	1167.1
6	-594.6	307.3	40	-300	997	74	799.5	592.6
7	-669.6	437.2	41	-375	1126.9	75	724.5	722.5
8	-744.6	567.1	42	354.9	162.7	76	649.5	852.4
9	-314.7	122.5	43	279.9	292.6	77	574.5	982.3
10	-389.7	252.4	44	204.9	422.5	78	499.5	1112.2
11	-464.7	382.3	45	129.9	552.4	79	799.4	927.4
12	-539.7	512.2	46	54.9	682.3	80	704.4	1057.3
13	-614.7	642.1	47	-20.1	812.2			
14	-689.7	772	48	-95.1	942.1			
15	-764.7	901.9	49	-170.1	1072			
16	-109.8	67.7	50	559.8	107.8			
17	-184.8	197.5	51	484.8	237.7			
18	-259.8	327.4	52	409.8	367.6			
19	-334.8	457.3	53	334.8	497.5			
20	-409.8	587.2	54	259.8	627.4			
21	-484.8	717.1	55	184.8	757.3			
22	-559.8	847	56	109.8	887.2			
23	-634.8	976.9	57	34.8	1017.1			
24	-709.8	1106.8	58	-40.2	1147			
25	20.1	142.6	59	689.7	182.8			
26	-54.9	272.5	60	614.7	312.7			
27	-129.9	402.4	61	539.7	442.6			
28	-204.9	532.3	62	464.7	572.5			
29	-279.9	662.2	63	389.7	702.4			
30	-354.9	792.1	64	314.7	832.3			
31	-429.9	922	65	239.7	962.2			
32	-504.9	1051.9	66	164.7	1092.1			
33	225	87.7	67	744.6	387.7			
34	150	217.6	68	669.6	517.6			

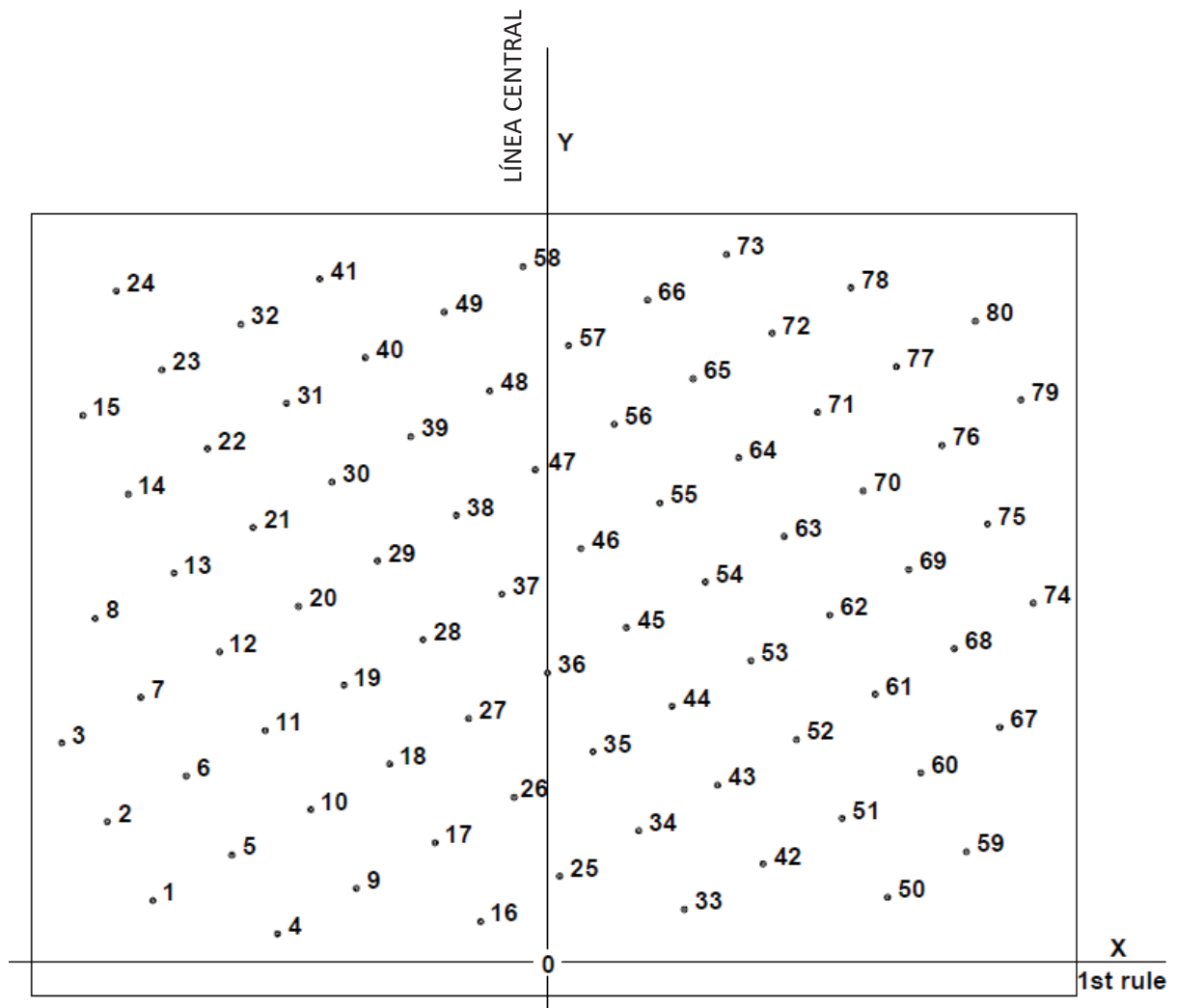
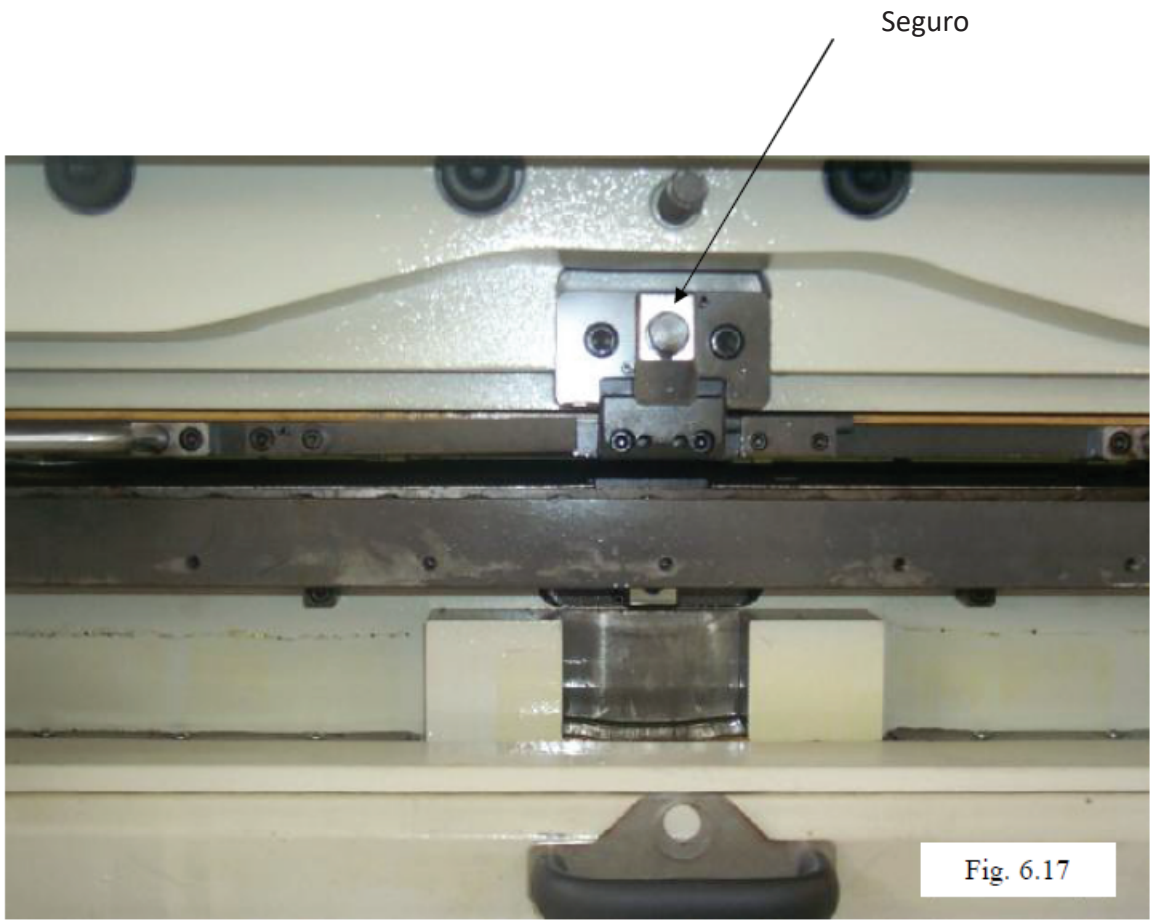

6.8.4 Troquelado con cuchilla para desperdicio de mordida de pinza de cogida.

- 1) Extienda cualquiera de las reglas cortadoras hasta el borde del mesa de troquelado para separar o cortar el desperdicio de la mordida de la pinza de cogida. (Fig. 6.18)
- 2) Reposicione los resortes superiores de la pinza de cogida y los asientos de la pinza de cogida de la barra de sujeción en el lugar donde se colocará la cuchilla, y para encajar el taponador de las puntas de la pinza PB20312 a la muesca. (Fig 6.19)

Atención:

1. Los materiales de la barra transversal donde se asienta las puntas de la pinza, y los del taponador de punta de la pinza, son las mismas que los de la placa de corte, los cuales son de dureza HRC50 para poder soportar la presión de corte.
2. Use PB20309, PB20310 y PB20311 como punta de la pinza situada transversalmente en la barra cuando el espesor de la placa de corte es de 7 mm o 6 + 1mm.
3. Use PB20322, PB20323 y PB20324 como punta de la pinza situada transversalmente en la barra cuando el espesor de la placa de corte es de 7 +1 mm.
4. La placa de corte de 6 mm no puede ser usada sola.

Ver Figura 6.20: Procedimiento para encajar la barra transversal donde se asienta las puntas de la pinza y el taponador de las puntas de la pinza.

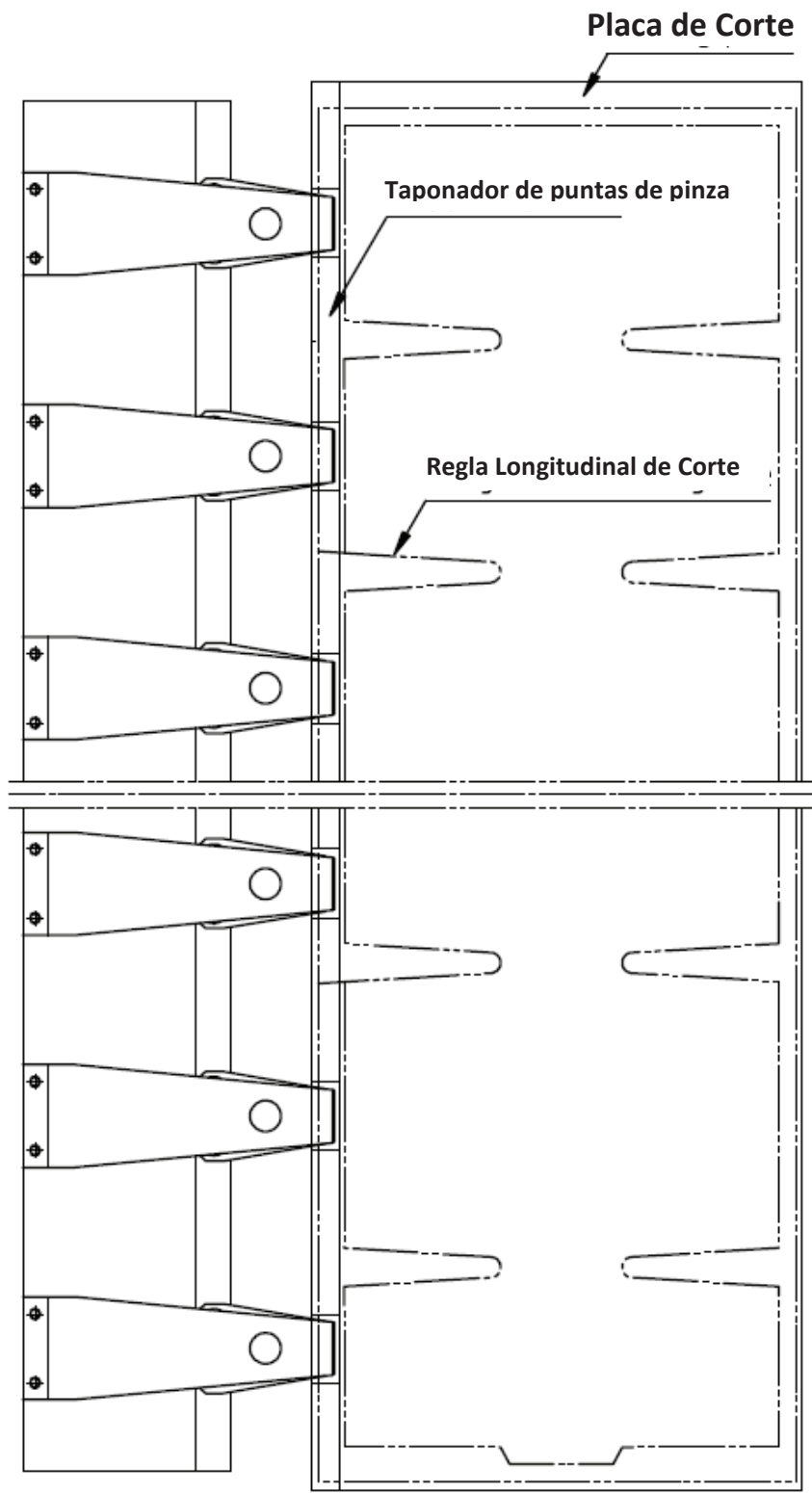

Fig 6.18

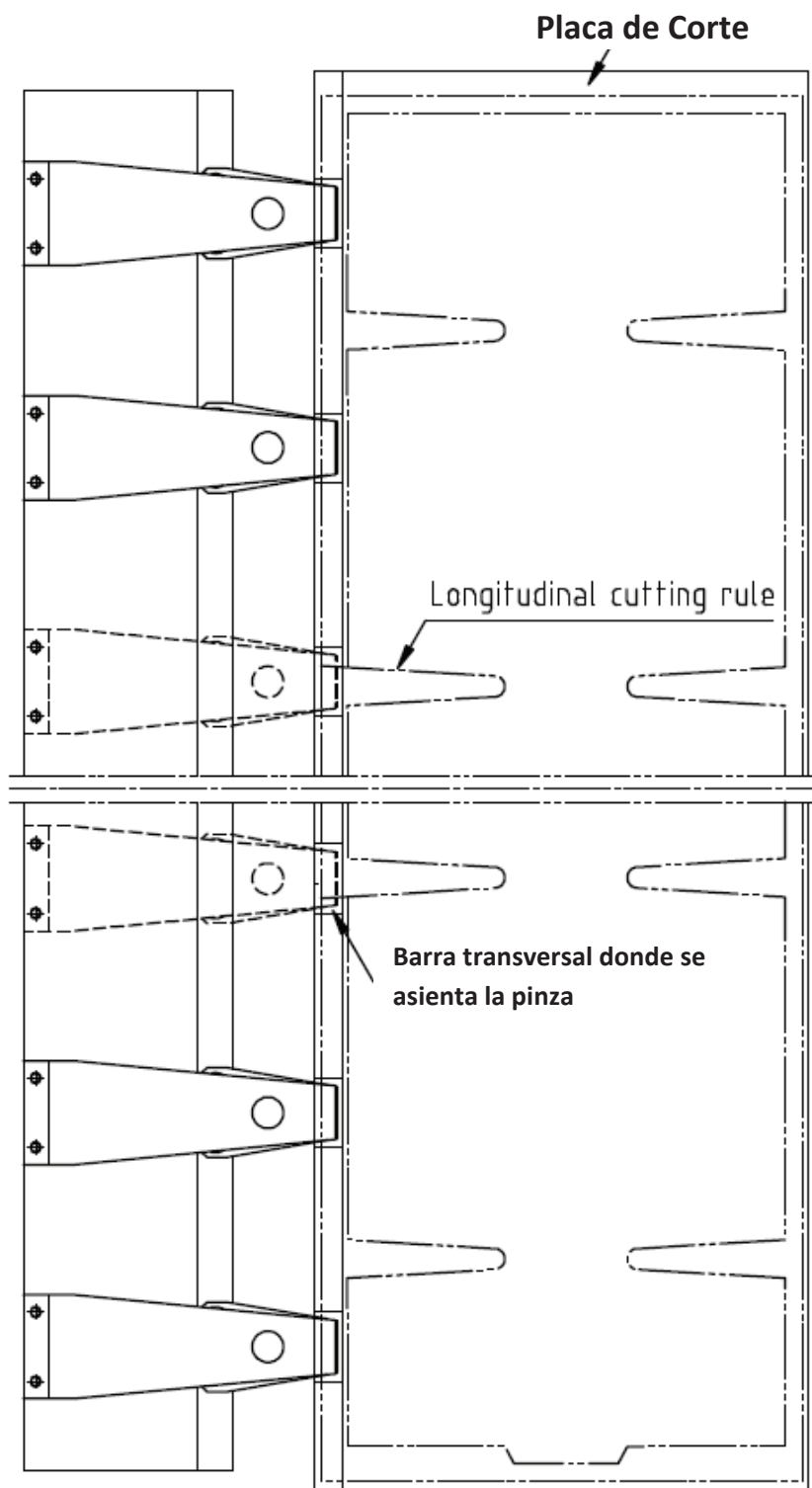

Fig 6.19

6.8.5 Troquelado sin margen de la pinza.

- 1) Extienda las reglas de corte longitudinales hacia el borde del mesa de troquelado. (Fig 6.21)
- 2) Reposicione los resortes superiores de la pinza de cogida y los asientos de la pinza de cogida de la barra de sujeción en el lugar donde se colocará la cuchilla, y para encajar el taponador de las puntas de la pinza PB20312 a la muesca. (Fig 6.22)

Atención:

1. Los materiales de la barra transversal donde se asienta las puntas de la pinza y del Taponador de puntas de la Pinza son los mismos que la placa de corte el cual es de dureza HCR50 para soportar la presión de corte.
2. Use PB20309, PB20310 y PB20311 como barra transversal donde se asienta las puntas de la pinza cuando el grosor de la placa de corte es 7+1 mm o 6+1 mm.
3. Use PB20322, PB20323 and PB20324 como barra transversal donde se asienta las puntas de la pinza cuando el grosor de la placa de corte 7+1 mm.
4. La placa de corte de 6 mm no puede ser usada sola. Véase Fig. 6.20: Procedimiento para encajar la barra transversal donde se asienta las puntas de la pinza y el Taponador de puntas de la Pinza.

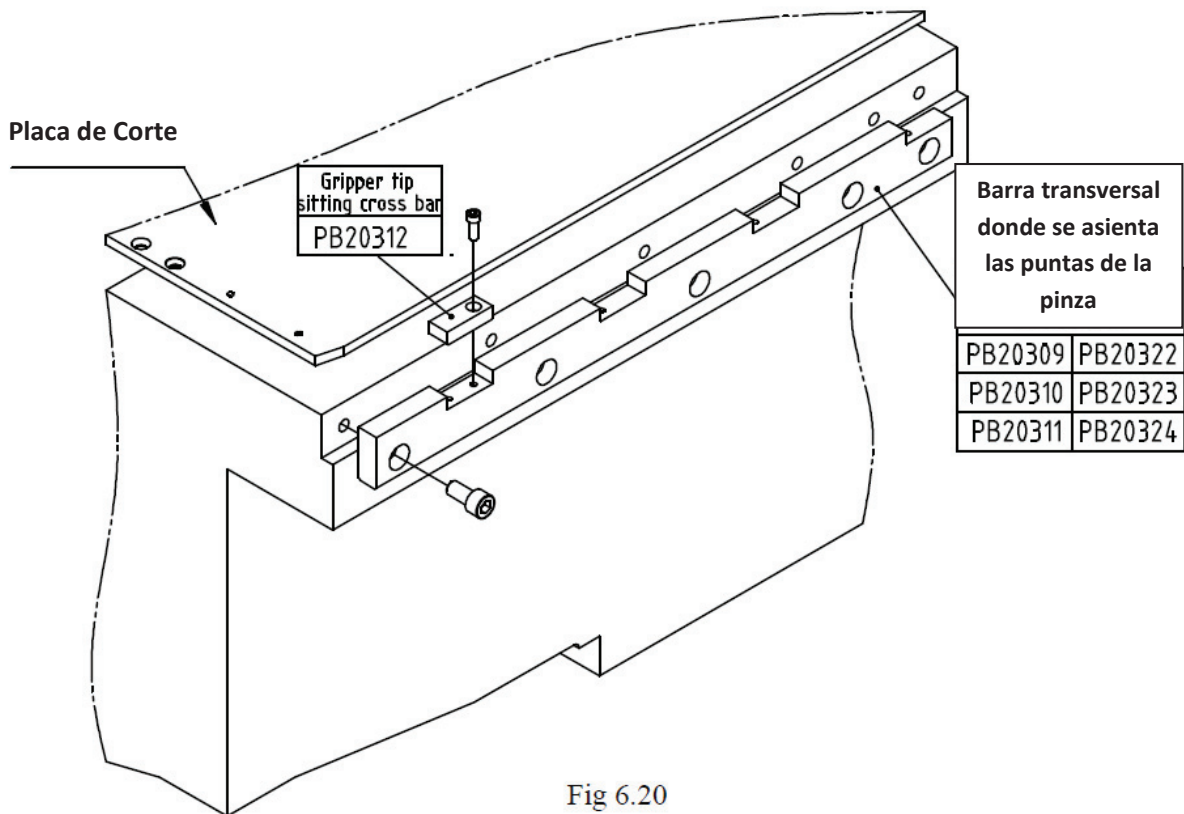

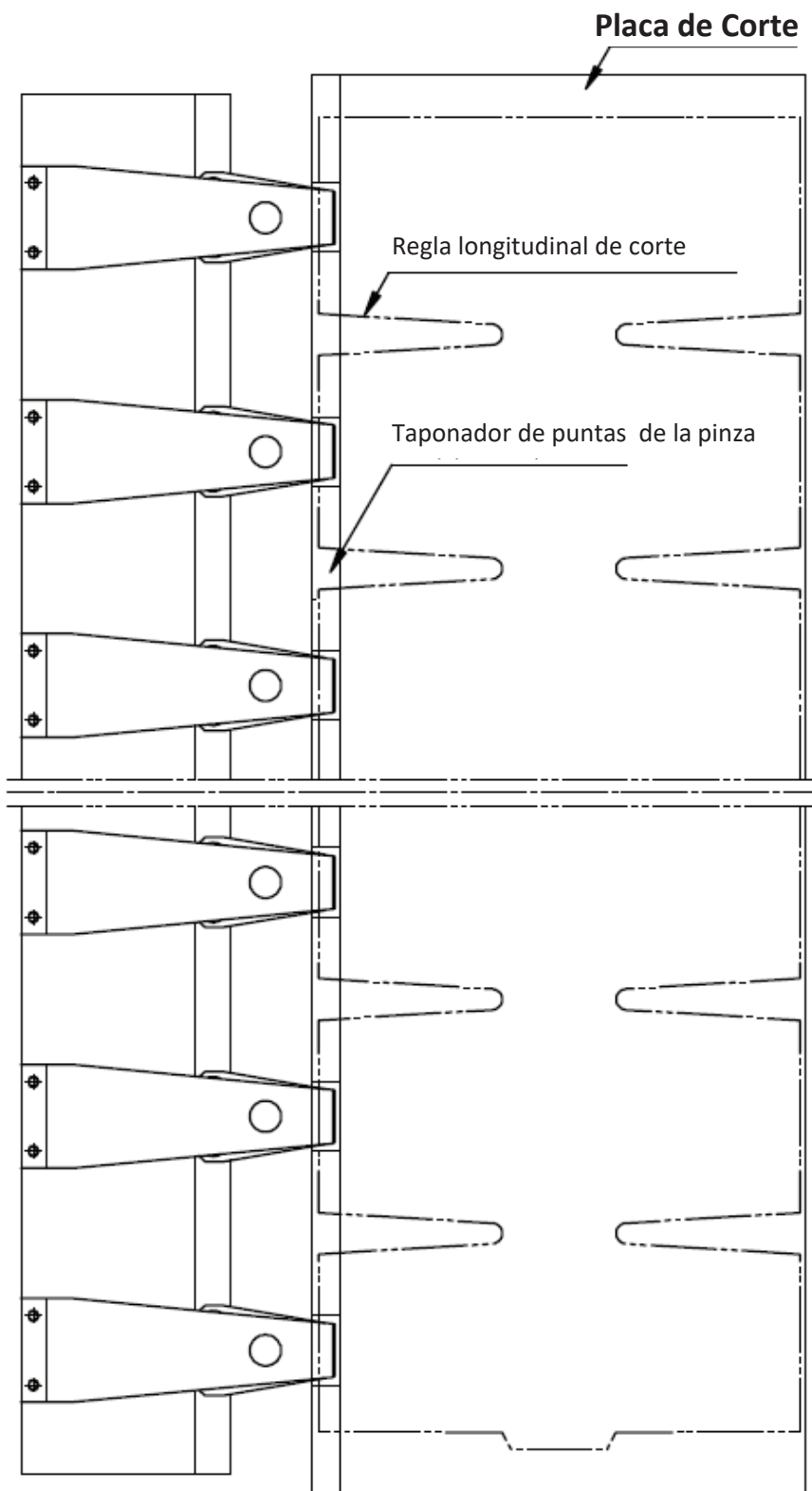

Fig 6.21

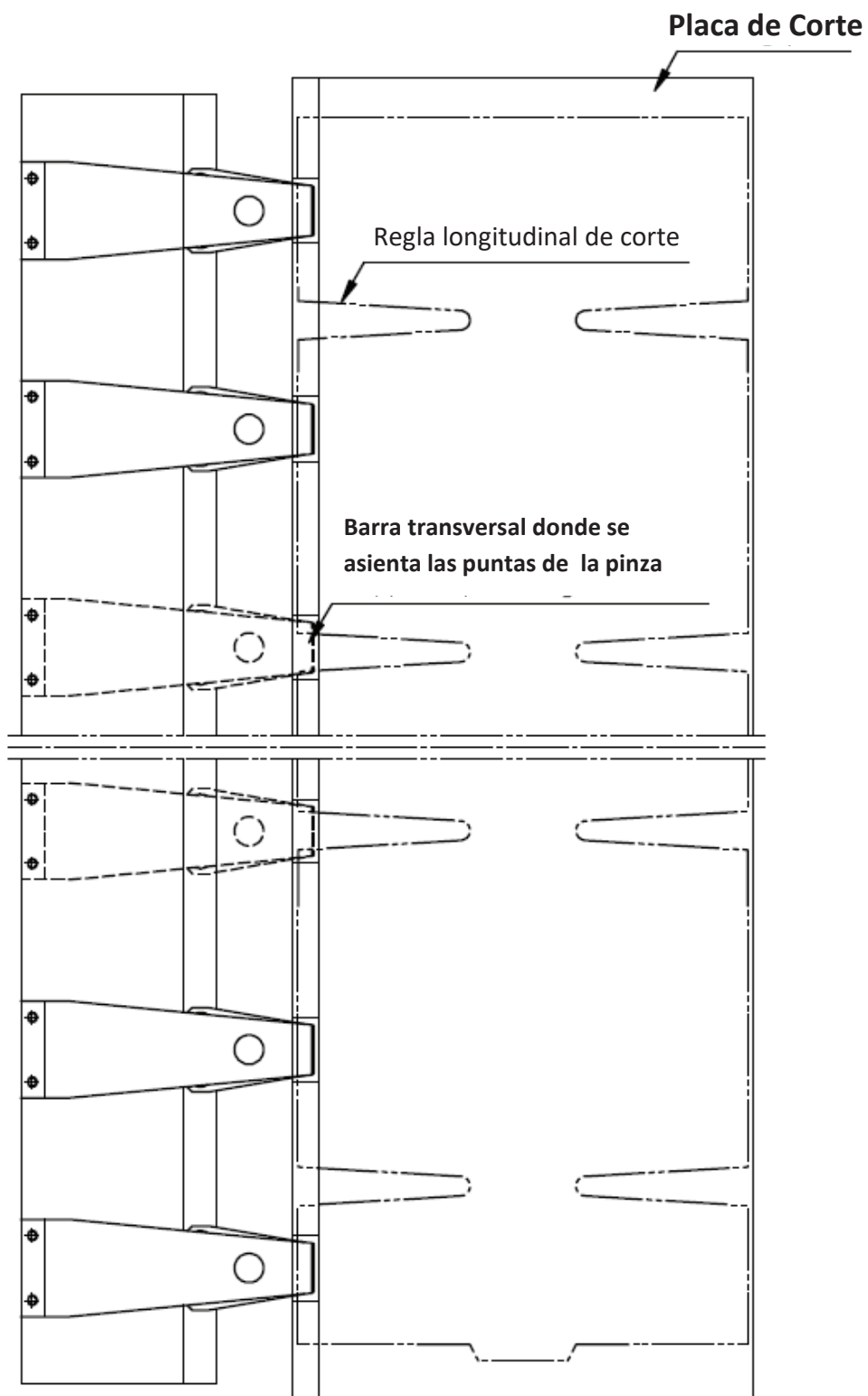

Fig 6.22

ETERNA

INSTRUCCIONES

PE1620SA-Extra

Capítulo 7

PROCESO DE REMOCIÓN DE DESECHOS

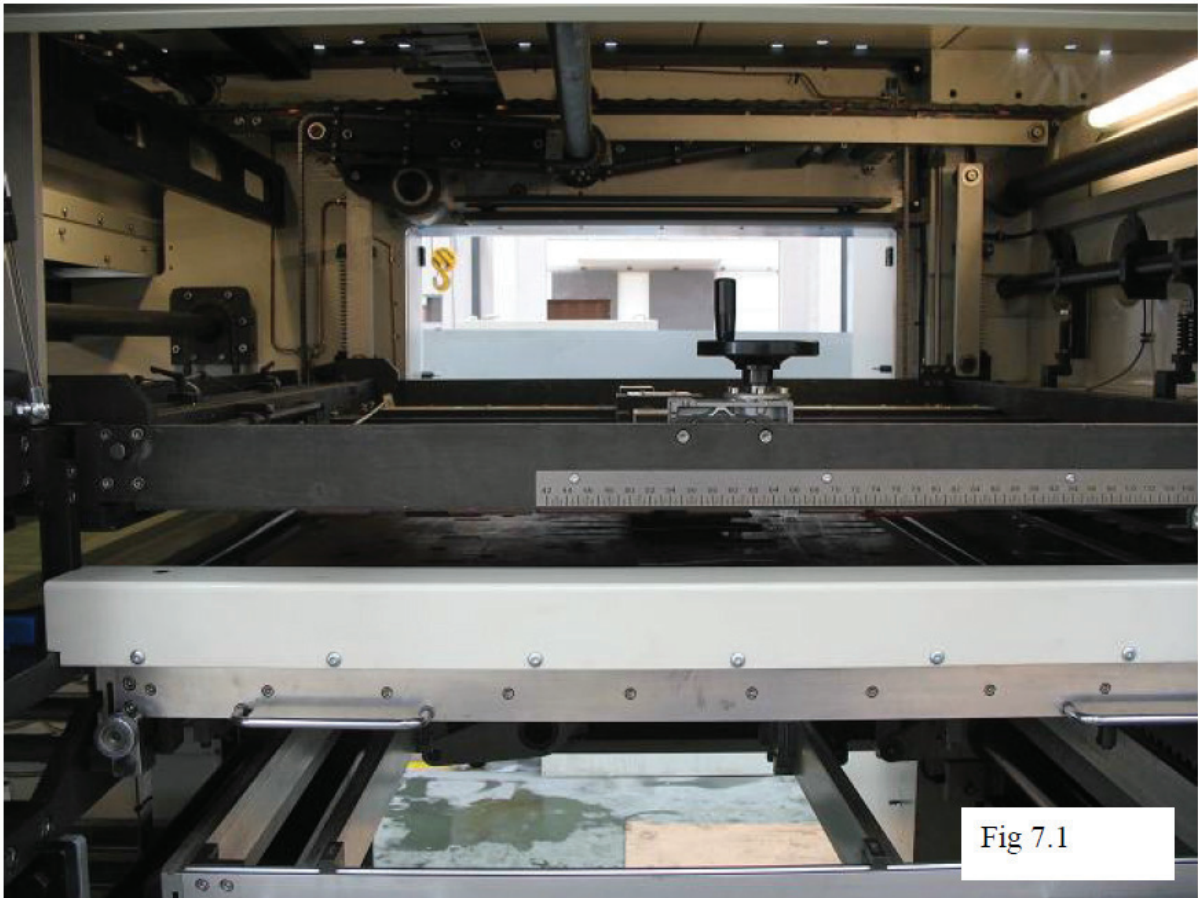

Sistema Internacoinal De Ejes

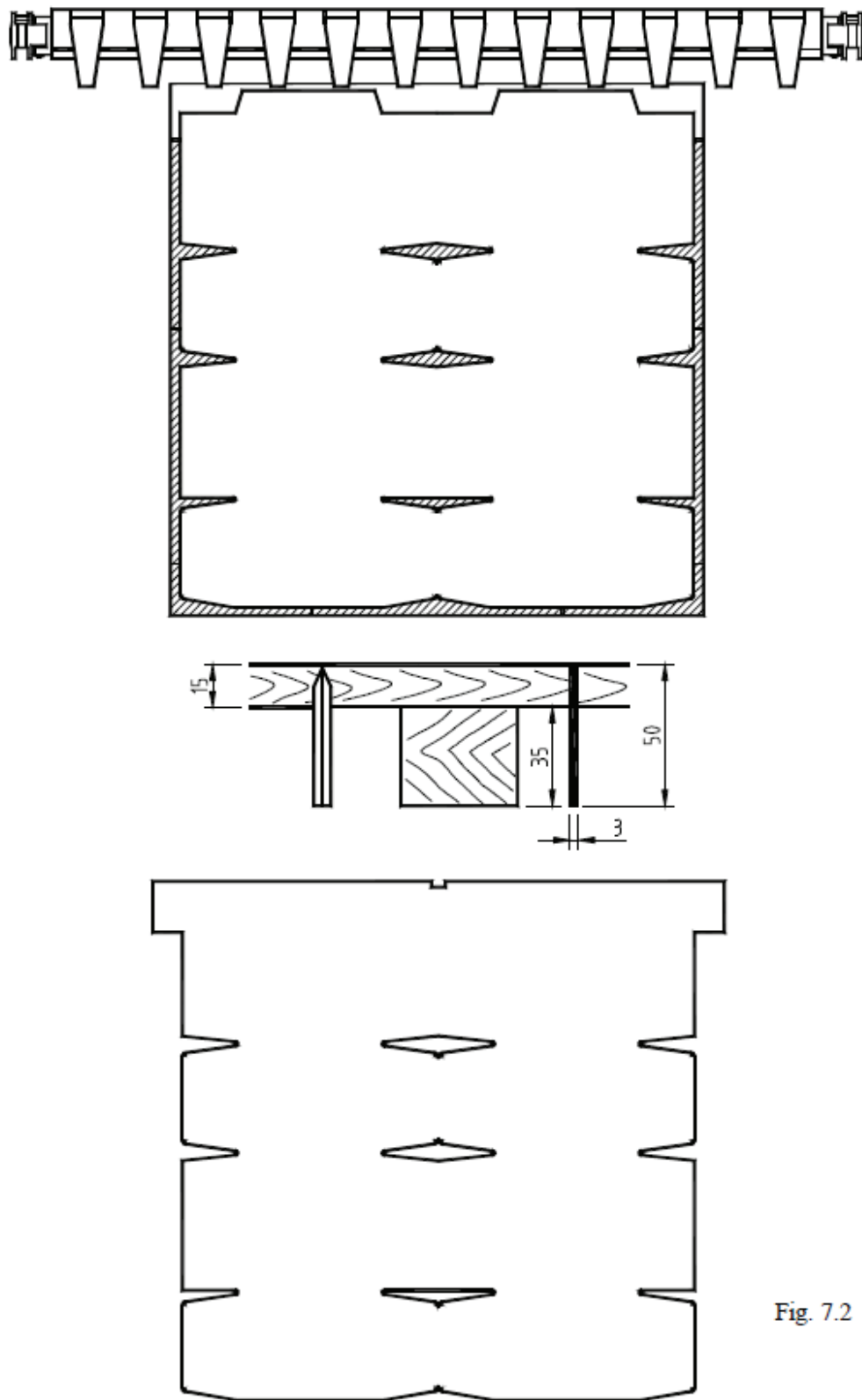
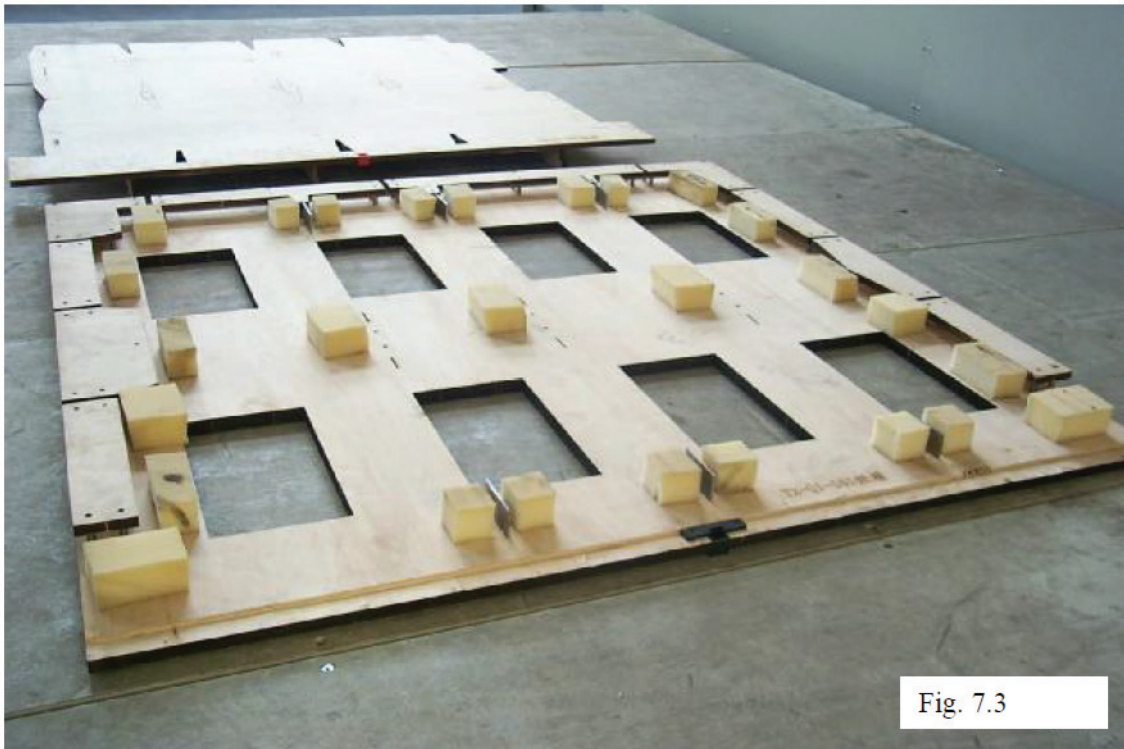

Fig. 7.2



Tablero macho removedor de desecho (superior)



Encaje de Tablero hembra removedor de desecho

7. REMOVEDOR DE DESPERDICIOS

7.1. DESCRIPCIÓN (fig. 7.1 & fig. 7.2)

7.1.1. Operación

La estación de remoción de desperdicios, consiste en un marco superior, en el cual la cuchilla macho es encajada. Y un marco inferior removible, con un tablero hembra para remoción, para ser cortados acorde a los diseños de desperdicios.

Cuando la barra de sujeción se detiene, la lámina es empujada por el tablero de remoción y la cuchilla superior. Las piezas de desperdicio son removidas a través de las entradas del tablero. (fig. 7.3).

Tal como se muestra en la fig. 7.1 & fig. 7.2, Es posible remover los reguladores laterales y traseros, y también el desperdicio dentro de la lámina.

Hay dos tipos de cuchillas superiores:

- Los pernos de remoción
- Los troqueles de remoción que serán preparados por el fabricante del troquel junto al tablero hembra de remoción de desperdicio y el troquel.

7.1.2. Tablero hembra de remoción (Fig. 7.4)

Tablero hembra para remoción de desperdicio (fig. 7.4)

Material: Plywood Duro, Grosor 12 mm.

A ser fabricado conjuntamente con el troquel de corte por el fabricante del troquel.

7.1.3. Pernos para Remoción de desperdicio (Sujeto a diferentes modelos)(fig. 7.5)

Vienen provistos con la máquina, estas herramientas están diseñadas para ser ajustadas directamente en las barras transversales. Las hay en dos distintas longitudes.

Uso: Altamente recomendado para Trabajos Unitarios, corridas limitadas o extensas corridas de trabajo simple.

Ventajas: No hay necesidad de fabricar un troquel, fácil almacenamiento en espacios pequeños.

7.1.4. Troqueles para remoción de desperdicios (fig. 7.2 & fig. 7.3)

Material: Plywood Duro, grosor 15 mm (5/8").

Otras posibilidades son usar bloques de madera de 35 mm de alto y clavarlos al troquel, o en su defecto, placas metálicas para láminas de 50 x 3 mm, para que sean insertadas en el troquel.

Aplicación: Un troquel de remoción de desperdicio será fabricado para trabajos repetidos, para grandes corridas y para cualquier trabajo complejo.

Ventaja: Tiempo de preparación de la forma, es muy corto

El troquel para remoción de desperdicio debería ser fabricado a la par con el troquel de corte y por el mismo fabricante.



Fig. 7.5

Perno para remoción de desecho.

7.1.5. Almohadilla para Presión

Material: Espuma Sintética (como polyether or polyester),

Grosor: - Sin el troquel para remoción de desperdicio: 40 mm (1"- 1/2 ").

Buenos resultados se han obtenidos con densidades de la espuma entre 35-40 kg/m³ (2.2 to 2.5 lb/cu.ft – Libras sobre pies cúbicos)

Para poder tener franjas de material para ser usadas en ambos casos, corte franjas de 55 mm de ancho de una espuma de 40 mm.

Solo se necesita pegarlas del lado más amplio o más angosto, dependiendo de la altura necesaria.

Uso: Para mantener la lámina contra el tablero de remoción de desperdicio, cuando el desperdicio es removido.

7.2. ASCENSIÓN Y DESCENSO DE MARCO DE REMOCIÓN.

Ascensión: Oprima el botón 55 y manténgalo presionado. El marco se alzará hasta el tope de recorrido.

Quedará inoperativo durante la corrida de la máquina.

Detener durante la ascensión: Suelte el botón 55. El marco descenderá un poco más hasta que se detenga en la muesca de la rueda del trinquete.

Descenso: Oprima el botón 56 y manténgalo presionado. En la posición más baja el marco automáticamente se bloquea.

7.3. ENCAJE DEL TABLERO HEMBRA PARA REMOCIÓN DE DESPERDICIO (Fig. 7.4)

7.3.1. Descripción (Fig. 7.6 & Fig. 7.7)

El troquel para remoción más bajo es directamente suministrado al marco inferior de la cuchilla de remoción inferior, y la posición izquierda/derecha es determinada por el bloque de posicionamiento central.

7.3.2. Montaje del tablero hembra en la prensa.

1. Empuje el chase para remoción al fondo y cierre el seguro.
2. Alimente una lámina a la máquina, córtela, luego muévala hacia adelante sobre el tablero hembra hasta que este alcance su posición superior.
3. Ajuste la posición del tablero de acuerdo a la lámina, remueva el desperdicio con la mano y ajuste con precisión.
4. Asegure ajustando todas las tiras.

7.3.3. Separando los reguladores laterales del regulador trasero.

Tal como se muestra en la Fig. 7.8. Es necesario tener un apoyo inferior en el lugar de corte para separar el regulador trasero de los laterales. Este soporte puede ser hecho separando los dispositivos de encaje con una pieza de regla de corte (preferiblemente 28.6 mm). También es posible fabricar partes especiales para que sean atornilladas a la placa.



Fig. 7.6



Fig. 7.7

Tablero hembra para remoción de desperdicio (medio)

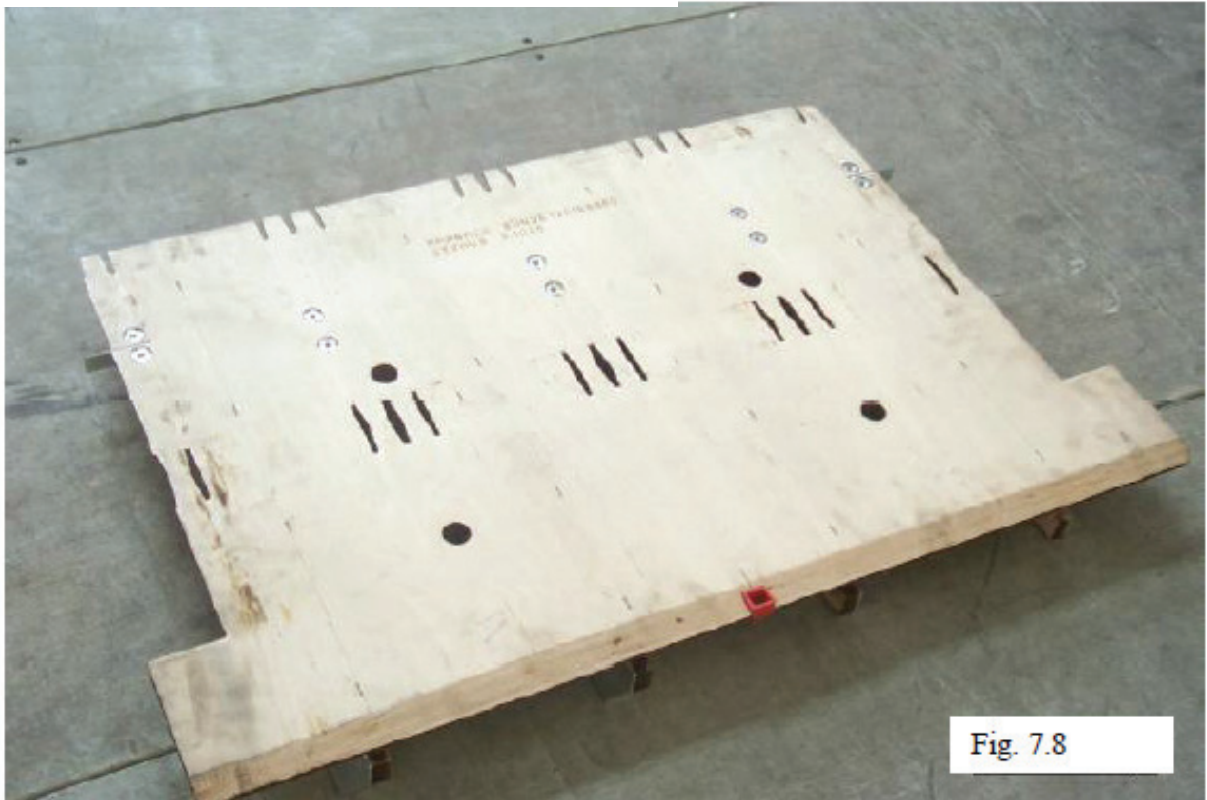

Fig. 7.8

Soporte inferior para regulador trasero

7.4. Troquelado SIN REMOCIÓN DE DESPERDICIO

Cuando se realiza un troquelado sin remoción de desperdicio, para asegurar una tablero de madera en el marco inferior para remoción, y servir de soporte a la lámina que viaja por encima.

ETERNA

INSTRUCCIONES
PE1620SA-Extra

Capítulo 8

SUMINISTRO



Fig. 8.1



Fig. 8.2

Barra transversal superior de transporte



Sacando la Barra transversal superior de transporte



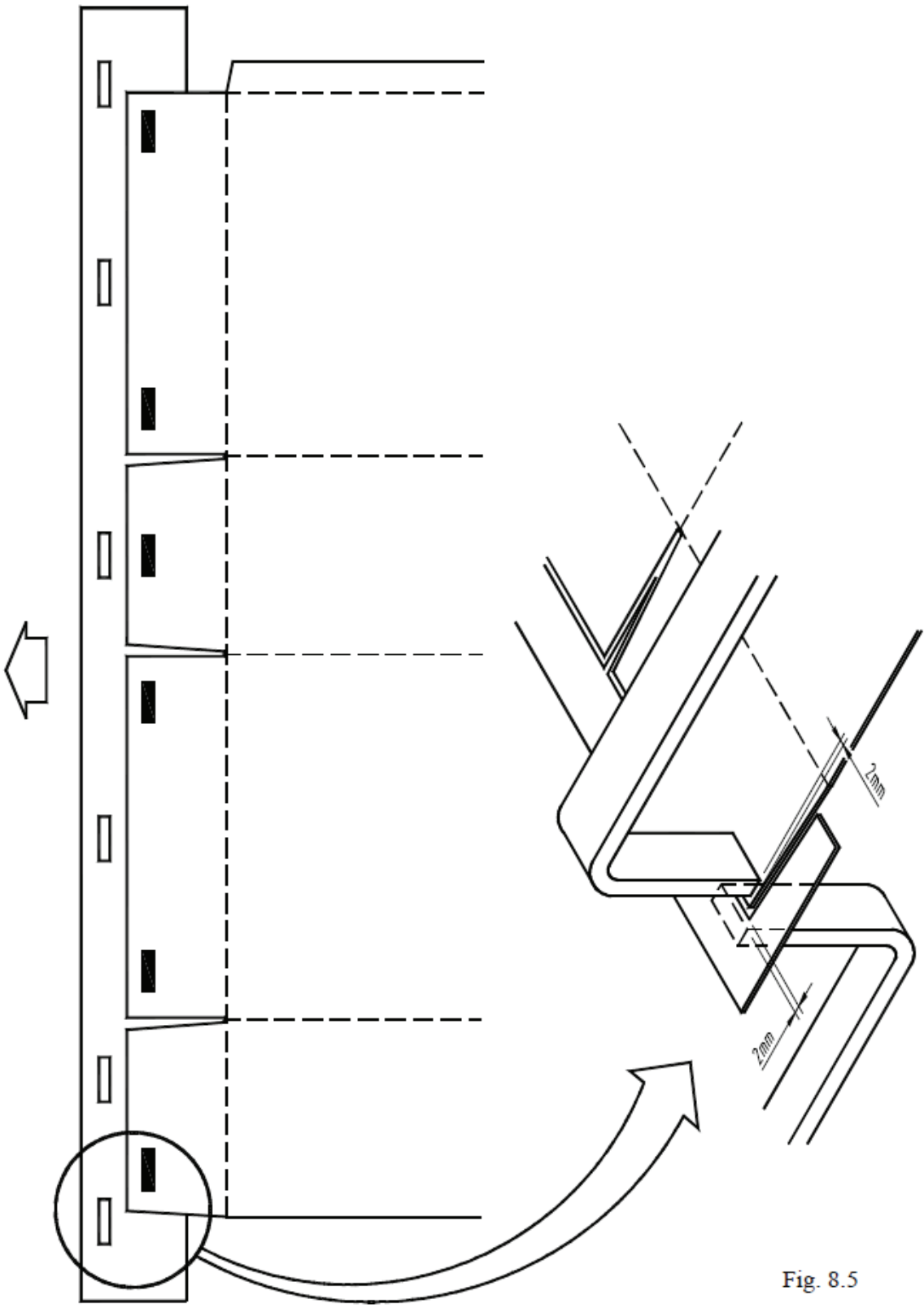

Fig. 8.5

8. SUMINISTRO

8.1. Descripción

Realice la corrida de una lámina hasta la fase de suministro, antes de que la pinza libere la lámina, detenga la máquina. En este punto, la cola de la lámina deberá asentarse en la lengua de la cola de la lámina (fig. 8.4). Si el soporte trasero (fig. 8.4) no está en posición, presione el botón 61 o 62 (hacia adelante y hacia atrás) para mover el soporte trasero a esta posición. Luego, simplemente ajuste las emparejadoras laterales a ambos lados de la lámina. Un espacio de 15 mm debe de ser dejada entre el borde de la lámina y el lado de la emparejadora.

8.2. Remoción de desperdicio de borde frontal. Operación

1. Detenga la máquina en 180° mediante la marcha intermitente (la pantalla LCD mostrará el ciclo de la máquina en grado). Cambie el interruptor 65 hacia la izquierda.
2. Desmantele el abridor de las pinzas de cogida. (fig. 8.3 fig.8.6)
3. Cambie el interruptor de mecanismo de empuje de láminas al lado de la línea entrecortada.(fig. 8.1) Para desenganchar el mecanismo de empuje de láminas. (fig 8.7)
4. Empuje la barra de cuchillas inferior en el barra transversal inferior transportadora de cuchillas desde la ventana del lado del suministro. Cambie el interruptor 65 hacia la derecha para que sea agarrado. (Rodillo Inferior. Instrucciones de Fabricación fig 8.8)
5. Realice una corrida a una lámina al suministro hasta que las barras transversales transportadoras de cuchillas estén tan cerca de la lámina como sea posible. Para asegurarse de que el tope de cuchilla inferior este a 1-2mm alejado de la cortada del primer cuchillo. (fig. 8.5)
6. Separe los espacios en blanco del desperdicio frontal, manualmente. El desperdicio frontal todavía es sostenido por las pinzas de cogida.
7. Cambie el interruptor 64 hacia la izquierda.
8. Empuje la barra superior de cuchillas en la barra transversal superior transportadora de cuchillas (fig. 8.1-fig. 8.3) del lado de la ventana de suministro.
9. Cambie el interruptor 64 hacia la derecha para asegurar la cuchilla.
10. Para ajustar la posición de la cuchilla superior position para asegurarse de que el tope sea 1-2mm alejado de la cortada del primer cuchillo.
Observación: Si el troquel de remoción de desperdicio frontal es usado, realice el mismo procedimiento, pero omita el ajuste mencionado en # 10.
11. Cambie el interruptor 63 hacia la derecha para accionar el abridor de pinzas de cogida de desperdicio frontal.

8.3. Contador de Preselección

Configure el número de láminas por lote en el contador 73. Presione el botón debajo del dial para

operar el
contador.



Fig. 8.6

Barra transportadora de abridores de pinzas de cogida

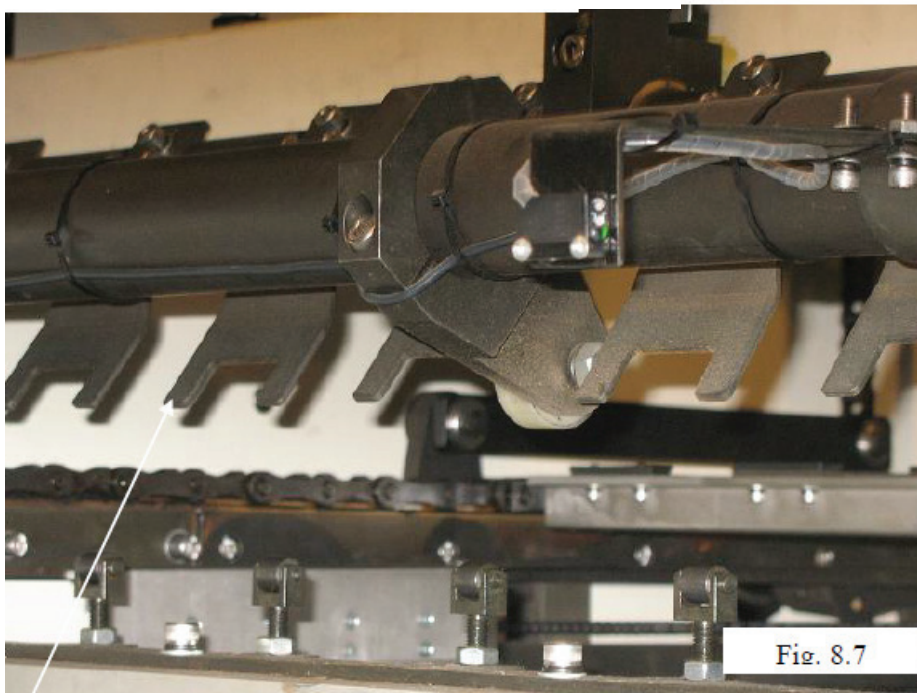
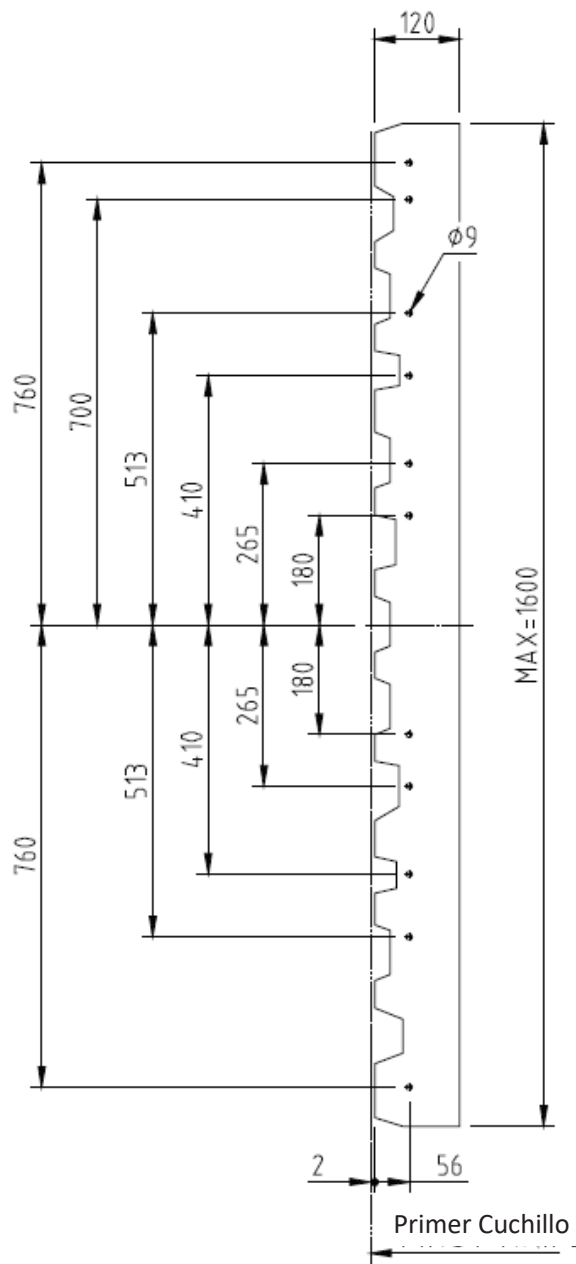

Fig. 8.7

Mecanismo de empuje de láminas en la cuchilla superior



Molde de Troquel de Martillo del borde delantero de remoción de desperdicios

Fig. 8.8

GROSOR= 18mm

8.4. La transportadora de rodillos en Suministro

La transportadora de rodillos en suministro es un accesorio delicado de operar. Los Clientes deberían prestar atención a las reglas de seguridad para prevenir que alguien se lastime debido a operación inadecuada.

ETERNA





**INSTRUCCIONES
PE1620SA-Extra**





Capítulo 9

MONTAJE Y PROCESO DE PREPARACIÓN DE LA FORMA.

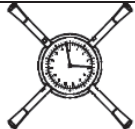



9. MONTAJE Y PROCESO DE PREPARACIÓN DE LA FORMA.

Paso a paso para montar un trabajo.

Paso No.	UBICACIÓN	OPERACIÓN	Referencia
1.	TROQUELADORA	Remover el troquel del trabajo anterior.	
2.	REMOVEDOR DE DESPERDICIOS	Remover las cuchillas de remoción o el troquel removedor de desperdicios de la corrida anterior, quedando el tablero de remoción de desperdicios hembra en la máquina para que las láminas de la nueva corrida puedan pasar sin problema alguno durante los ajustes.	
3.	SUMINISTRO	<p>Troquelado sin remoción de desperdicio de borde frontal:</p> <ol style="list-style-type: none"> 1. Desbloquear la cuchilla para remoción de desperdicio de la parte frontal superior girando el interruptor 64 a la izquierda. Saque la cuchilla. Y gire hacia la derecha para bloquear el transportador. 2. Desbloquear la cuchilla para remoción de desperdicio de la parte frontal inferior girando el interruptor 65 a la izquierda. Saque la cuchilla. Inserte el abridor de la pinza y posicónelo correctamente. Gire el interruptor hacia la derecha para bloquear el contenedor. 3. Girar el interruptor para empuje de láminas 62 a la línea real. 4. Retire el abridor de pinzas para desperdicio frontal girando el interruptor 63 a la derecha. <p>Troquelado sin márgenes de la pinza: Idéntico a procedimiento mencionado. Algunas pinzas deberán ser removidas dependiendo del patrón de corte.</p>	 <p>64</p>  <p>65</p>  <p>62</p>  <p>63</p>
4.	TROQUELADORA	Encaje en Nuevo troquel en la mesa para troquel, asegure el troquel con los tornillos. Balancéelo con un troquel para compensar en caso de ser necesario.	6.5
5.	TROQUELADORA	Coloque la lámina para proceso de ajuste de forma y péguela en la parte trasera del plato de ajuste, alineadas con la reglas de corte.	6.7
6.	TROQUELADORA	Reduzca la fuerza de corte girando la manivela de control de fuerza en dirección opuesta las manecillas del reloj por 2 ciclos. Normalmente, cuando se lo hace a 2 ciclos, el plato de prensa se moverá hacia abajo unos 0.2mm (0.1mm/por ciclo)	 <p>6.2.1</p>

Paso No.	UBICACIÓN	OPERACIÓN	Referencia
7.	TROQUELADORA	Inserte la mesa para troquel en la máquina. Oprima el botón 20 para asegurar la mesa para troquel Apriete el seguro.	6.6.1
8.	TROQUELADORA	En caso de ser necesario, prepare el complemento o contraparte de acuerdo al sistema adoptado, canal o cartón prensado.	6.8.3
9.	ALIMENTADOR	Ajuste el margen de la pinza a 15 mm (coloque el dial en 15).	 5.2.9
10.	ALIMENTADOR	Ajuste las guías laterales presionando el pulsador 33, 34 o 35.	 5.2.1
11.	ALIMENTADOR	Ajuste la posición del soporte trasero.	5.2.2
12.	ALIMENTADOR	Ajuste la altura del gancho de la guía frontal oprimiendo el pulsador 31 o 32. (Lámina propensa a deformarse)	 5.2.4
13.	TROQUELADORA	<p>Incremente la fuerza de corte girando la manivela de control de fuerza en dirección de las manecillas del reloj por 1 ciclo. El plato de prensa se moverá hacia arriba 0.1mm (0.1mm/por ciclo).</p> <p>Lleve a cabo una prueba de troquelado, revise el ajuste frontal y lateral.</p>	
14.	ALIMENTADOR	<p>Si es necesario, corrija el ajuste.</p> <ul style="list-style-type: none"> - Longitudinalmente ajustando el <i>front lay</i>. - transversalmente moviendo las guías laterales. 	

Paso No.	UBICACIÓN	OPERACIÓN	Referencia
15.	TROQUELADORA	<p>Incremente la fuerza hasta que un 80% ó 90% del patrón sea cortado correctamente.</p> <p>Mantenga la máquina funcionando sin láminas durante 3 o 5 minutos para que las reglas tomen posición. Retire la mesa para troquel, y realice un proceso de ajuste de forma.</p> <p>Alimente otra lámina a la máquina, revise y realice nuevamente dicho proceso, si es necesario. Luego, coloque la mesa para troquel de vuelta a su lugar.</p>	 <p>6.7</p>
16.	REMOVEDOR DE DESPERDICIOS	<p>Desmantele el tablero hembra de la corrida anterior, y coloque el nuevo. Alimente una nueva lámina a la máquina, empújela al removedor de desperdicios. Ajuste la posición del tablero en relación a la lámina. Asegure o apriete todas las correas. (Si el Sistema Internacional Cobra para Sistema de Ejes es usado, no se requiere ajustes para la posición del tablero hembra).</p>	7.3.4
17.	REMOVEDOR DE DESPERDICIOS	<p>Encaje las cuchillas superiores de cualquiera de estos tipos:</p> <ul style="list-style-type: none"> - Cuchillas de fijación rápida. - Troquel removedor de desperdicio (Si el Sistema Internacional Cobra para Sistema de Ejes es adoptado). 	7.1
18.	SUMINISTRO	<p>Realice la corrida con una lámina hasta la fase de suministro. Ajuste la posición del apoyo trasero oprimiendo el botón 61 o 62.</p> <p>Luego, ajuste los emparejadores laterales en ambos lados de la lámina.</p>	8.1

Paso No.	UBICACIÓN	OPERACIÓN	Referencia
19.	SUMINISTRO	<p>Troquelado con remoción de desperdicio de borde frontal:</p> <ol style="list-style-type: none"> 1. Gire el interruptor 64 a la izquierda. Inserte la barra de cuchillas de remoción de borde frontal. Gire el interruptor hacia la derecha para agarrar la cuchilla al transportador 2. Gire interruptor 65 a la izquierda. Saque el abridor de la pinza. Inserte la barra de cuchillas inferior de remoción de borde frontal. Gire el interruptor hacia la derecha para agarrar la cuchilla al contenedor. 3. Girar el interruptor para empuje de láminas 62 a la línea entrecortada. 4. Girar el interruptor 63 hacia la derecha para engranar el abridor de pinza de remoción de borde frontal. 5. Encienda la cinta transportadora para desperdicio de borde frontal en la parte alta de la máquina. 	 <p>64</p>  <p>65</p>  <p>62</p>  <p>63</p> <p>8.2</p>
20.	ESCRITORIO DE CONTROL	Configura el número de láminas por lote en el contador.	8.3
21.		Use la alimentación no programada para cargar unas cuantas láminas a la máquina, supervise la alimentación, el corte, la remoción de desperdicio, la remoción de desperdicio de borde frontal y el suministro. Corregir si es necesario.	
22.		Ponga en marcha la máquina para una corrida continua. Revise la primera lamina troquelada, y ajuste con precisión en caso de ser necesario.	
23.		<p>Si la máquina funciona con normalidad, comience la producción oprimiendo el botón 44. La máquina a se acelerará automáticamente a la velocidad puesta en el potenciómetro 43. SI la velocidad necesita ser restaurada, coloque el potenciómetro 43 a la posición que represente la velocidad deseada. Oprima el botón 46 para comenzar la aceleración o la desaceleración.</p> <p>Oprima el botón 46 nuevamente, la velocidad de la máquina disminuirá a la marcha muy lenta. Oprímalo una vez más, y regresará a la velocidad deseada.</p>	

ETERNA

INSTRUCCIONES
PE1620SA-Extra

Capítulo 10

Pantalla Táctil LCD

Pantalla # 2

Gire el interruptor de llave en el panel de operaciones principal de la máquina anfitrión hacia el estado de Encendido y la pantalla táctil deberá mostrar el logo de ETERNA, luego entrará la pantalla # 1 automáticamente.



Pantalla # 1

Muestra la apariencia visual de la máquina. Seleccione la línea de abajo para entrar a la Pantalla # 16.

Seleccione la línea superior para entrar a la Pantalla # 7.

Entrar a Pantalla # 2

Welcome to use PE1620 Flatbed Automatic Die cutter

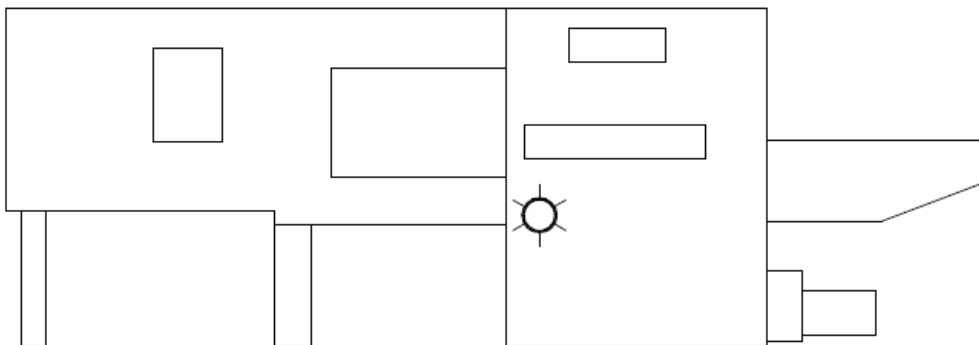

ETERMA Shanghai Eterna Precision Machinery Manufacture Co. Ltd

Entrar a Pantalla # 3

Pantalla # 3

Dirección y contacto del fabricante o distribuidor



**Shangai ETERNA Manufactura de Maquinaria
de Precisión Ltda.**

Dirección de la Fábrica

**1125 Calle: Taishun, Pueblo: Anting,
Distrito: Jiading. Shangai 201814**

**Telf: (021) 59502451
Fax: (021) 59502490**

Return

Product

Pantalla # 2

Esta es la pantalla del Menú Principal, incluyendo 8 funciones.

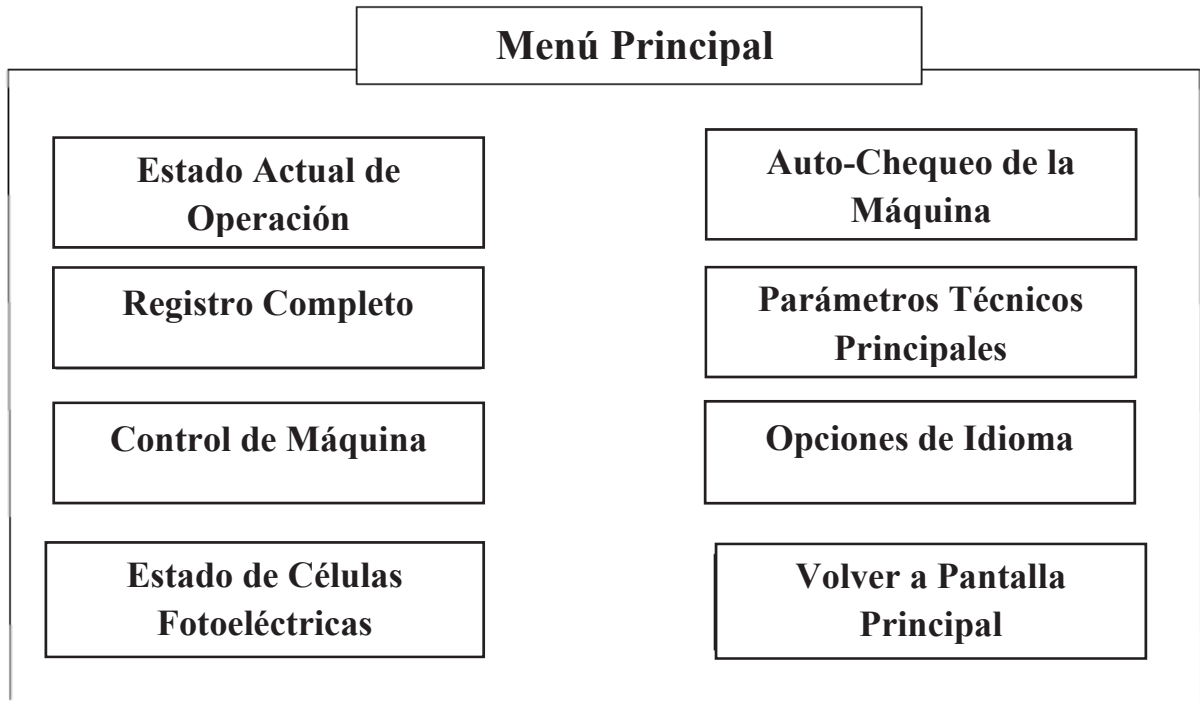

Estado Actual de Operación

Ir a Pantalla # 10 para mostrar la velocidad de operación y ángulo de la máquina

Auto-chequeo de la Máquina

Ir a Pantalla # 25, para mostrar el auto-chequeo de todas las partes de la máquina

Registro Completo

Ir a Pantalla # 70, para mostrar el registro de operaciones de la máquina. Ejemplo: Total de Láminas, registros de trabajos, etc.

Parámetros Técnicos Principales

Ir a Pantalla # 50, para mostrar el los parámetros técnicos principales

Control de Máquina

Ir a Pantalla # 40, para mostrar el pequeño ajuste de retraso del cilindro, control de apoyo lateral, ajuste de tiempo de los apoyos lateral, suministro y provisión de aire.

Opciones de Idioma

Ir a Pantalla # 60, para mostrar 2 opciones de lenguaje

**Estado de las Células
Fotoeléctricas**

Ir a Pantalla # 30, para mostrar el estado de todas las células fotoeléctricas de la máquina.

**Volver a Pantalla
Principal**

Retornar a Pantalla # 1

Pantalla # 25

Condiciones normales de funcionamiento y condiciones anormales de funcionamiento de todas las partes de la máquina.

Auto-chequeo de la máquina		Volver a Principal	
Motor Principal	Alarma	Sección de Alimentación	Error
Bomba Lubricación	Alarma	Troquelado	Error
Embrague Principal	No Cerrada	Remoción de Desperdicio	Error
Operación de la máquina	Detenido de Emergencia	Suministro	Error
Prueba de barra de sujeción	Anormal	PLC	Error
Célula Fotoeléctrica	No ha sido usada	Compuerta de Seguridad	No Cerrada

Pantalla # 209

Prueba de la célula Fotoeléctrica de la Sección para Remoción de Desperdicios.

Error de la sección para Remoción Desperdicios - Detección

**Prueba de Célula Fotoeléctrica de la sección
para Remoción de Desperdicios**

Normal

**Si la prueba de célula fotoeléctrica de la sección para remoción
de desperdicio está anormal, revise y limpie la sección par
remoción de desperdicio.**

**Regreso a
Pantalla Principal**

**Regreso a Pantalla de
Auto-Chequeo de
Máquina**

Pantalla # 202

Detección de Presión de Aceite.

Alarma para Tubería a de Aceite/Presión Insuficiente de Aceite --- Posible Causa

1. El interruptor NFB6 no está cerrada o el Proceso de Remoción.
2. Sobrecarga de la bomba de Aceite de motor M3 ó fase de Ausencia Operacional.
3. Pantalla de atascamiento del filtro de aceite y de la tubería de aceite ó de bajo nivel del tanque.

Nota: Cuando la presión del aceite no sea suficiente, no ponga en marcha la máquina por ningún motivo o de ninguna forma.

**Volver a la Pantalla
Principal**

**Volver a Pantalla de
Auto-chequeo de
máquina**

Detección de
presión de Aceite

Anormal

Interruptor de Aire

Cerrado

Motor de la Bomba
de Aceite

Sobrecarga

Pantalla # 203

Detección de Presión de Aire.

Falla del embrague de la Máquina anfitrión--- Posible Causa

1. El compresor de aire no está puesto en marcha.
2. Atasco en la tubería de aire, ingreso de agua o fuga.
3. Micro interruptor de Presión de aire no está debidamente ajustado;

Nota: La presión de aire debe de ser más de 5Kg/cm² (70PSI)

Prueba de Presión de Aire

Normal

Volver a pantalla
Principal

Volver Pantalla de
Auto-chequeo de
máquina

Pantalla # 204

Varias causas que dan como resultado el Detenido de Emergencia

Detenido de Emergencia --- Posible Causa	
<ol style="list-style-type: none">1. El botón de detenido de Emergencia ha sido fue presionado2. La alimentación de poder el interruptor de llave ha sido interrumpida.3. El interruptor de Bloqueo ha sido puesto en la posición de Bloqueo4. La palanca de protección contra Bloqueo no ha sido restaurada a su posición original.	
Volver a la Pantalla Principal	Volver Pantalla de Auto-chequeo de máquina

Pantalla # 212

Detección de la compuerta de seguridad de todas las partes de la máquina

Detalle del Estado de la Compuerta de Seguridad	
Compuerta de Seguridad de la Sección de Alimentación	Cerrado
Compuerta de Seguridad de la Sección de Troquelado	Cerrado
Compuerta de Seguridad de la Superficie de operación de las pinzas	Cerrado*
Compuerta de Seguridad debajo de la cinta de transporte para desperdicio	Cerrado*
Compuerta de Seguridad sobre la cinta de transporte para la sección de remoción de desperdicio	Cerrado*
Compuerta de Seguridad grande en Suministro	Cerrado*
Ventana pequeña en Suministro	Cerrado*
Volver a Pantalla Inicial	Volver a Pantalla de Auto-chequeo de la máquina

Pantalla # 206

Si es que la Detección de la Célula Fotoeléctrica está encendida

Célula Fotoeléctrica No está en uso --- Posible Causa

Interruptor para la "Detección de la Célula Fotoeléctrica" no se encuentra en la posición de encendido.

**Volver a la Pantalla
de Auto-chequeo de
máquina**

**Volver a la Pantalla
Principal**

Pantalla # 201

Detección del Motor Principal

Alarma para Motor Principal --- Posible Causa

1. Fase de ausencia Operacional, sobretensión o baja tensión provenientes de la fuente de alimentación de poder.
2. El interruptor de ventilación NFB2 no está cerrado.
3. Motor Principal M1 tiene una sobrecarga operativa o se encuentra en la fase de ausencia Operacional.
4. Alarma del convertidor o Unidad de frenado.

Auto-Chequeo

Volver a la Pantalla
Principal

Interruptor de Aire

Cerrado

Volver a Pantalla de
Auto-chequeo de
máquina

Convertidor

Normal

Unidad de Frenado

Sobrecalentado

Pantalla # 205

Detección del torque del embrague y de la pinza de sujeción

Falla del embrague de la Máquina anfitrión--- Posible Causa

1. El compresor de aire no está puesto en marcha.
2. Atasco, ingreso de agua o fuga de la tubería de gas.
3. Micro interruptor de Presión Aire no está debidamente ajustado;

Nota: La presión de aire debe exceder los 5Kg/cm² (70PSI)

Auto-chequeo de Troque del Embrague

Desenganchar

Volver a pantalla
Principal

Volver Pantalla de
Auto-chequeo de
máquina

Pantalla # 207

Detección de la sección del Alimentador

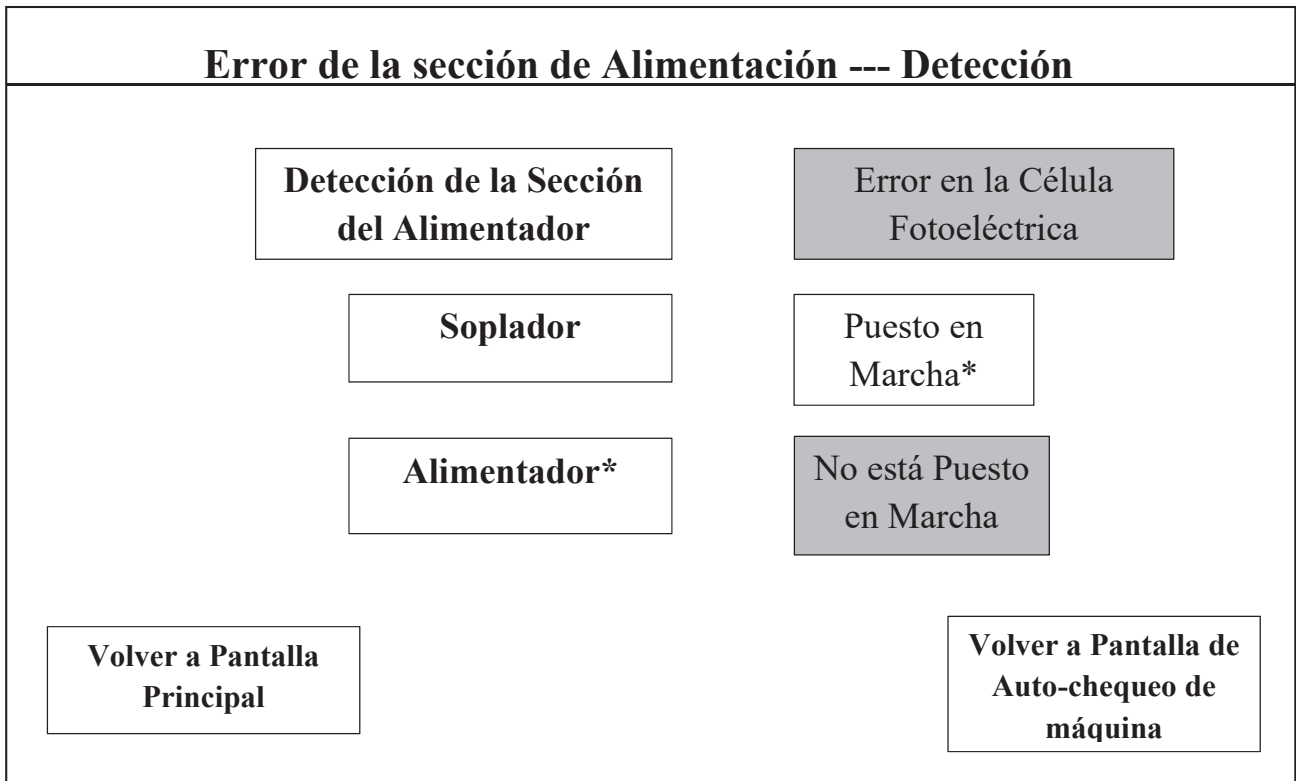

Pantalla # 208

Detección de la sección de Troquelado

Error de la sección de Troquelado --- Detección		Regresar
Detección del seguro Lateral de Alimentación de la Mesa de Troqueles.	Cerrado	
Detección del seguro Central de la Mesa de Troqueles	Cerrado	
Detección del seguro lateral de Descarga de la Mesa de Troqueles	Cerrado	
Detección del seguro de la placa de Acero para Troquelado.	Cerrado	
Descarga del Troquelado.	Cerrado	
Descarga Presurizada	Cerrado	

Pantalla # 210

Detección de la sección de Suministro

Error de la sección de Suministro --- Detección

**Célula Fotoeléctrica de detección de desorden
de láminas**

Normal

**Célula Fotoeléctrica para Detección de
Marcha Intermitente**

Normal

Mesa para Suministro

Normal

**Célula Fotoeléctrica para extracción segura del
cilindro**

Normal

**Regresar a
Pantalla Principal**

**Regresar a Pantalla de
Auto-Chequeo de
Máquina**

Pág. Siguiente

Pantalla # 50

Parámetros Técnicos Principales de la Máquina

Principales Parámetros Técnicos (1)	
Tamaño Max. de Lámina	<input type="text" value="....."/>
Tamaño Min. de Lámina	<input type="text" value="....."/>
Ancho viable de Lámina	<input type="text" value="....."/>
Tamaño Max. De Troquelado	<input type="text" value="....."/>
Tamaño de Guía Internas de la mesa de troqueles	<input type="text" value="....."/>
Tamaño del plato de troquelado de acero.	<input type="text" value="....."/>
Volver a Pantalla Principal	Pág. Siguiente

Pantalla # 51

Parámetros Técnicos Principales de la Máquina

Principales Parámetros Técnicos (2)	
Fuerza Max. De Troquelado	••••••• Toneladas •
Ancho Min. Del margen	••••••••••••••••••
Altura estándar del troquel	••••••••••••••••••
Velocidad Max. De la máquina	••••••• Láminas/h •
Alimentación de Poder	••••••••••••••••••
Peso Total de la máquina	••••• 32 Toneladas
Volver a Pantalla Principal	Volver a página Anterior

Pantalla # 211

Auto –chequeo del PLC

Error del PLC --- Posible Causa

- 1. El Cable de conexión está flojo.**
- 2. El terminal del cable no está conectado correctamente.**
- 3. Agotamiento de Baterías en el PLC.**

Detección de Llamadas

Agotadas*

**Volver a pantalla
Principal**

**Volver Pantalla de
Auto-chequeo de
máquina**

Pantalla # 71

Registros Completos de datos de la máquina

Registros Completos de la máquina	
Tiempo total de operación de la máquina	Horas
Total Veces de operación de la plancha de troquelado	Veces
Cantidad Total de troquelado	Láminas
Registro Actual de Trabajo		Volver a pantalla Principal

Tiempo total de operación de la máquina

Muestra el tiempo total de operación acumulado desde el primer día.

Total veces operación de la plancha de troquelado

Muestra las veces totales de operación de la plancha de troquelado acumulado desde el primer día.

Cantidad Total de troquelado

Muestra la cantidad total de troquelado acumulada desde el primer día.

Pantalla # 70

Estado actual del Trabajo. Presiones “Cero Registro de Trabajo”, ingrese a la pantalla 73 para limpiar el actual registro de trabajo.

Registros Actuales de Trabajo	
Láminas Estimada para troqueles -----	
Tiempo	Horas
Total de Láminas de Troqueles		Láminas
.....	
Regresar a Pantalla Completa	Cero Registros de Trabajos Actuales	Registros Comprensibles

Pantalla # 73

En pantalla 70 (Registro Actual de Trabajo), presione “Cero Registro s actuales de trabajo”, ingresar en esta Pantalla.

Presione “Confirmar” para borrar los registros actuales de trabajo.

Presione “Abandonar” para regresar a la pantalla anterior.

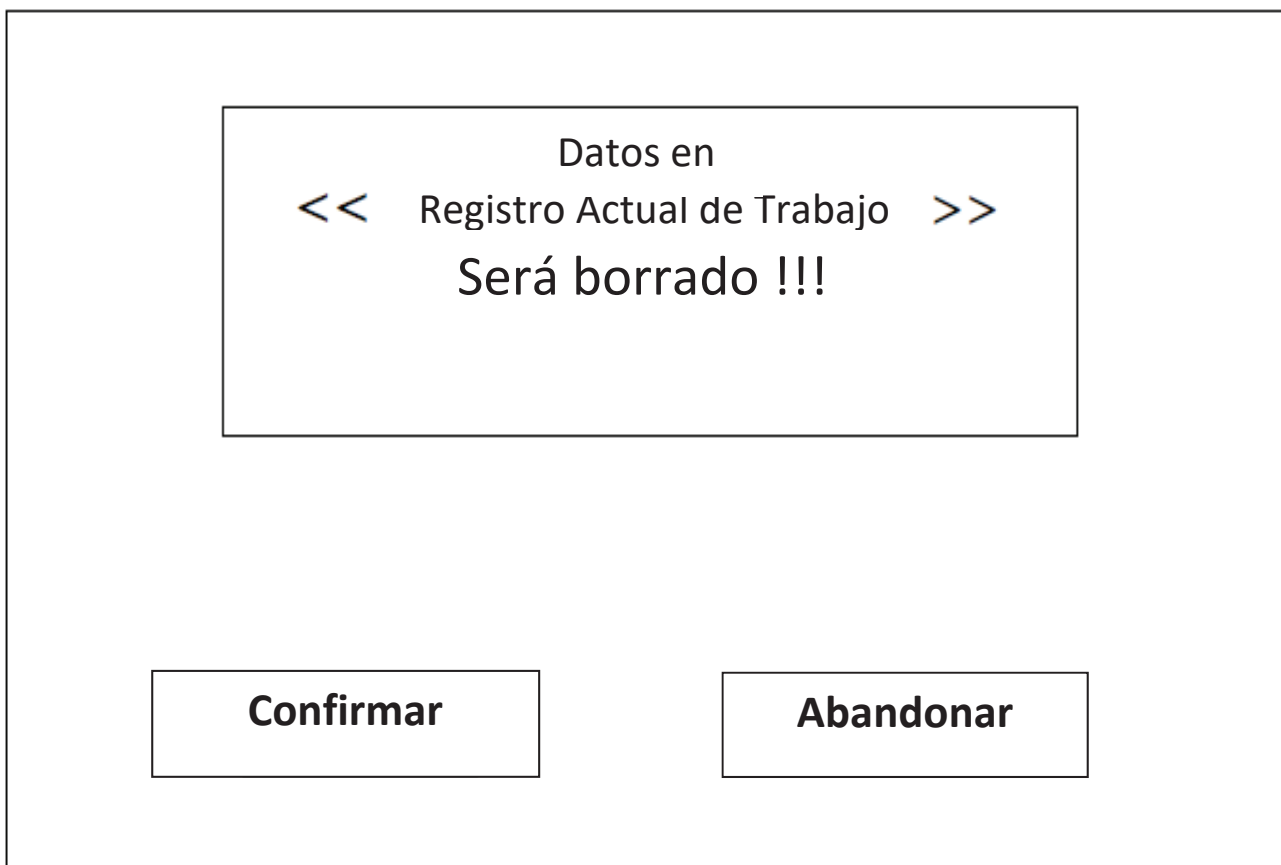

The image shows a software interface with a central message box and two buttons. The message box contains the text: "Datos en << Registro Actual de Trabajo >> Será borrado !!!". Below the message box are two buttons: "Confirmar" on the left and "Abandonar" on the right.

Pantalla # 10

Velocidad de Operación de la Máquina

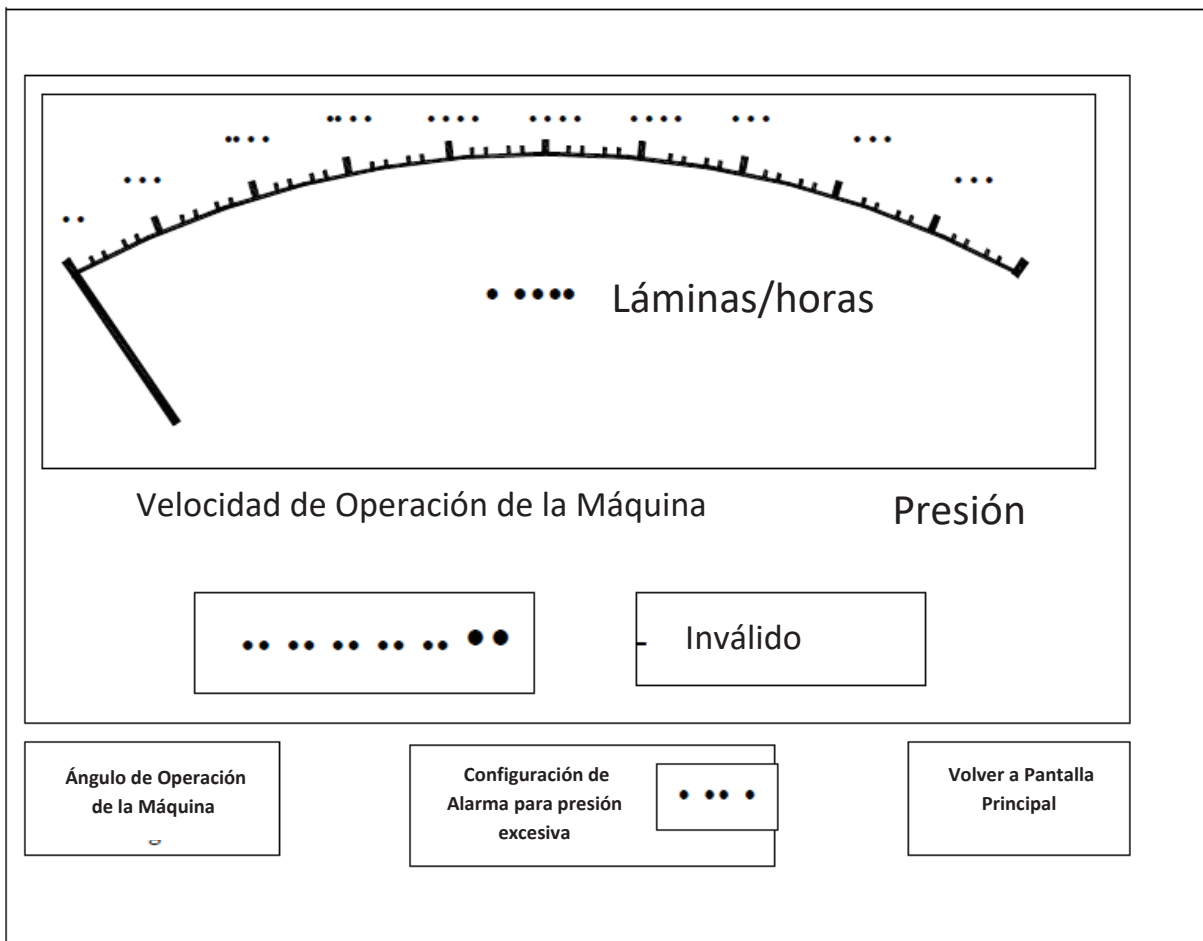

Pantalla # 11

Ángulo de Operación de la Máquina. Deberá ser usada cuando se configure el ángulo de detección de la máquina.

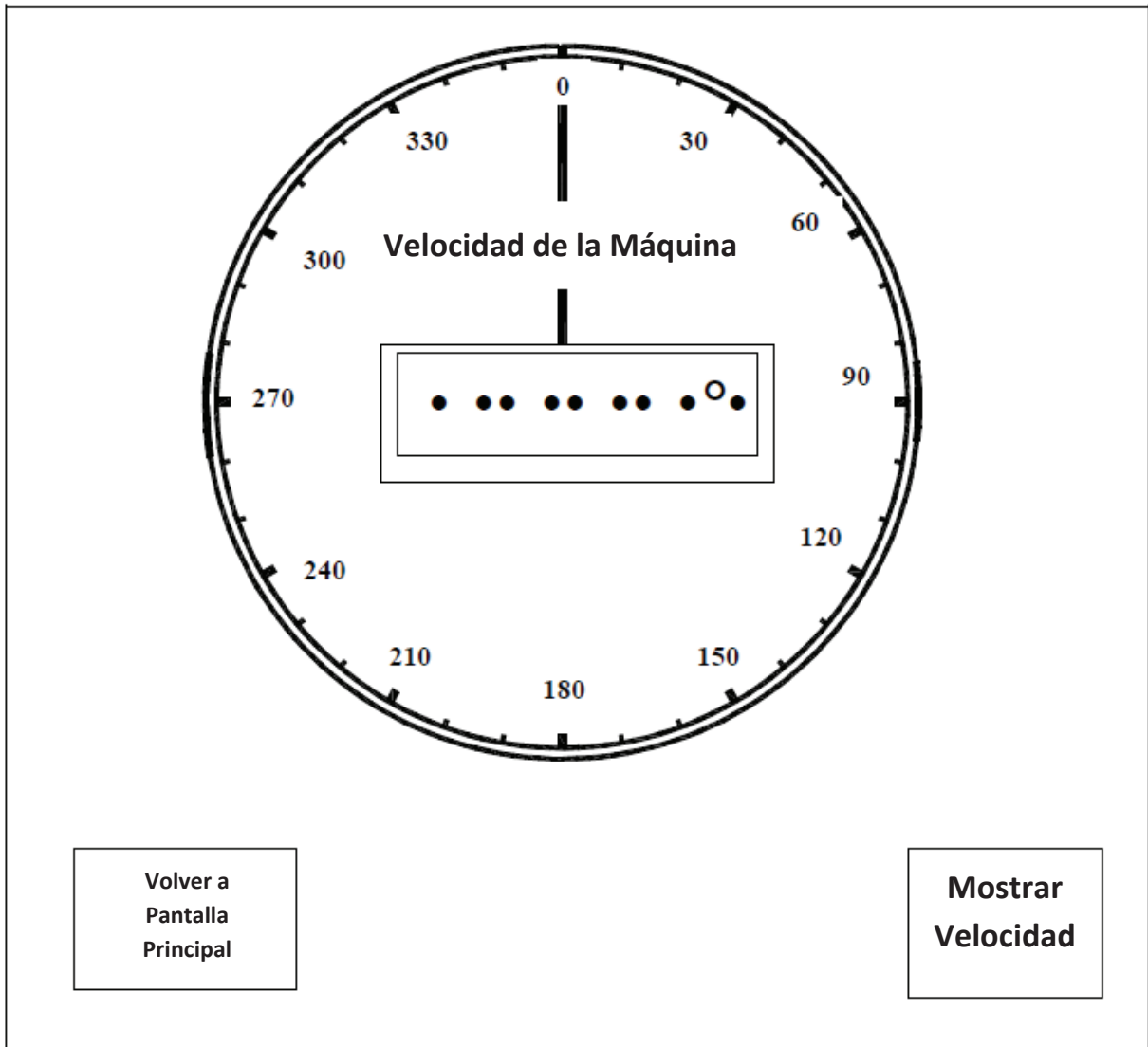

Pantalla # 14

Pantalla para configurar el ángulo de detección de la máquina, usada por el personal de mantenimiento.

Ítem de prueba	Ángulo Inicial	Ángulo Final
Detección de la pinza de cogida	<input type="text" value="....."/>	<input type="text" value="....."/>
Señal lateral de golpe en Alimentador	<input type="text" value="....."/>	<input type="text" value="....."/>
Excedente de Alimentación	<input type="text" value="....."/>	<input type="text" value="....."/>
Detección del Medidor de colocación Frontal de láminas	<input type="text" value="....."/>	<input type="text" value="....."/>
Pantalla de Ángulo de Operación de la Máquina	Cambiar Contraseña <input type="text" value="....."/>	Sig. Página

Detección de las pinzas de cogida	Para configurar el tiempo de detección de la pinza de cogida
Señal lateral de golpe de alimentador	Para configurar el tiempo de acción de golpe lateral del alimentador
Excedente del Alimentador	Para configurar el tiempo de detección de excedente de láminas
Bandeja frontal de láminas en orden	Para configurar el tiempo de detección de la bandeja frontal de láminas

Pantalla # 15

Pantalla para configurar el ángulo de detección de la máquina, solo para el uso del personal de mantenimiento de la máquina.

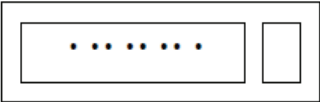
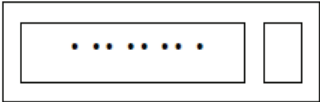
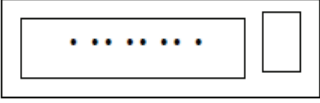
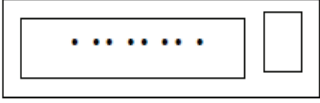
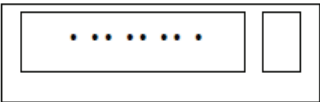
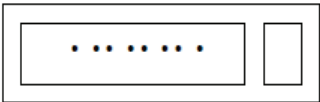
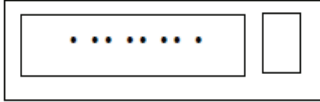
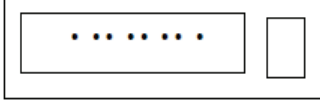
Ítem de prueba	Ángulo Inicial	Ángulo Final
Detección de la caída de las láminas colocadas		
Detección de la longitud de lámina		
Detección de la alimentación vacía de salida del troquelado		
Detección del troquelado de salida para láminas torcidas		
Pantalla de Ángulo de Operación de la Máquina	Pág. Anterior	Sig. Página

Detección de la caída de las láminas colocadas

Para configurar el tiempo de detección de la caída de las láminas colocadas

Detección de la longitud de lámina

Para configurar el tiempo de comienzo/fin para la detección de la longitud de la lámina.

Detección de la alimentación vacía de salida del troquelado

Para configurar el tiempo de detección de la alimentación vacía en la salida de descarga

Detección del troquelado de salida para láminas torcidas

Para configurar el tiempo de detección de láminas torcidas en la parte de salida del troquelado

Pantalla # 16

Pantalla para configurar el ángulo de detección de la máquina, solo para el uso del personal de mantenimiento de la máquina.

Ítem de prueba	Ángulo Inicial	Ángulo Final
Tiempo de extracción de Mesa de troquelado*	<input type="text" value="....."/>	<input type="text" value="....."/>
Detección alimentación vacía en la salida de desperdicios*	<input type="text" value="....."/>	<input type="text" value="....."/>
Detección del troquelado de salida para láminas torcidas*	<input type="text" value="....."/>	<input type="text" value="....."/>
Detección de suministro de láminas desordenadas*	<input type="text" value="....."/>	<input type="text" value="....."/>
Pantalla de Ángulo de Operación de la Máquina	Pág. Anterior	Sig. Página

Tiempo de extracción de Mesa de troquel*

Para configurar el tiempo para extraer la mesa de troquelado

Detección alimentación vacía en la salida de desperdicios

Para configurar el tiempo para la detección de alimentación vacía en la descarga de desperdicios.

Detección del troquelado de salida para láminas torcidas



Para configurar el tiempo de para las láminas torcidas en la parte de descargas de desperdicios.

Detección de suministro de láminas desordenadas.

Para configurar el tiempo de detección de las láminas desordenadas en la sección de suministro.

Pantalla # 17

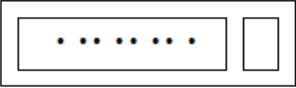
Pantalla para configurar el ángulo de detección de la máquina, solo para el uso del personal de mantenimiento de la máquina.

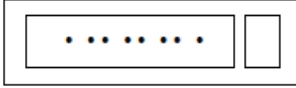
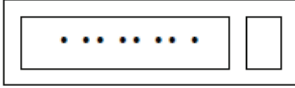
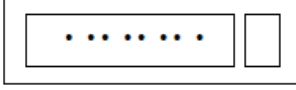
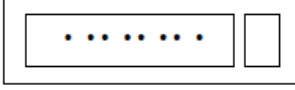
Ítem de prueba	Ángulo Inicial	Ángulo Final
Señal de la caída de Mesa de Suministro		
Sección de intermitencia del Suministro		
Sección de Alimentación Válvula de Mariposa #13		
Pantalla de Ángulo de Operación de la Máquina	Pág. Anterior	Sig. Página

Señal de la caída de Mesa de Suministro

Para configurar el tiempo de detección para el comienzo/fin de la señal de la caída de la mesa de Suministro

Sección de intermitencia del Suministro



Para configurar el tiempo de intermitencia de la sección de suministro.

Sección de Alimentación Válvula de Mariposa #13

Para configurar el tiempo de la válvula de escape de la sección suministro

Pantalla # 18

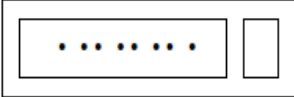
Pantalla para configurar el ángulo de detección de la máquina, solo para el uso del personal de mantenimiento de la máquina.

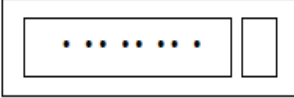
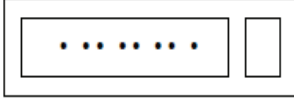
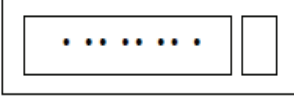
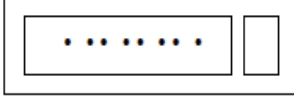
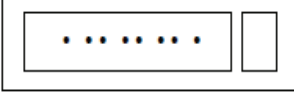
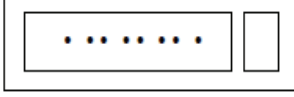
Ítem de prueba	Ángulo Inicial	Ángulo Final
Válvula # 14 del Alimentador		
Válvula de Detenido # 15 del Alimentador		
Señal de apoyo lateral para cinta transportadora de láminas		
Señal del intervalo de conteo de las láminas en Suministro		
Pantalla de Ángulo de Operación de la Máquina	Pág. Anterior	Pág. Siguiente

Válvula # 14 del Alimentador	Para configurar el tiempo de acción de la sección de alimentación de la válvula de aire
Válvula de Detenido # 15 del Alimentador	Para configurar el tiempo de acción de la palet pequeña de alimentación
Señal de apoyo lateral para cinta transportadora de láminas	Para configurar el tiempo de detección del apoyo lateral de las láminas en suministro
Señal del intervalo de conteo de las láminas en Suministro	Para configurar el tiempo de comienzo/fin del intervalo de conteo de láminas

Pantalla # 19

Pantalla para configurar el ángulo de detección de la máquina, solo para el uso del personal de mantenimiento de la máquina.

Ítem de prueba	Ángulo Inicial	Ángulo Final
<div data-bbox="252 631 635 734" style="border: 1px solid black; padding: 5px; text-align: center;">Señal de flujo de aire de Suministro</div>	<div data-bbox="702 638 1018 734" style="border: 1px solid black; padding: 5px; text-align: center;">• • • • •</div>	<div data-bbox="1077 638 1393 734" style="border: 1px solid black; padding: 5px; text-align: center;">• • • • •</div>
<div data-bbox="303 855 566 1014" style="border: 1px solid black; padding: 5px; text-align: center;">Pantalla de Ángulo de Operación de la Máquina</div>	<div data-bbox="1104 878 1383 996" style="border: 1px solid black; padding: 5px; text-align: center;">Pág. Anterior</div>	

Señal de suministro de flujo de aire

Para configurar el tiempo para suministro de flujo de aire

Pantalla # 12

Presione el botón activo # 12 de la mesa: esta pantalla aparecerá, esto significa que la mesa activa de la máquina se detiene en el punto más bajo y que la mesa de troquelado puede ser retirada.

La máquina ha sido colocada en la posición de punto para extracción. El troquel puede ser extraído.

Volver a la pantalla Principal

Volver a la pantalla de Auto-chequeo de la máquina

Pantalla # 214

Detección en ambos casos, cuando el troquel para desperdicio superior/inferior estén asegurados. Presione el botón para marcha intermitente #28 o el botón de operación continuo # 27, y en troquel superior o inferior no se haya asegurado, esta pantalla aparecerá.

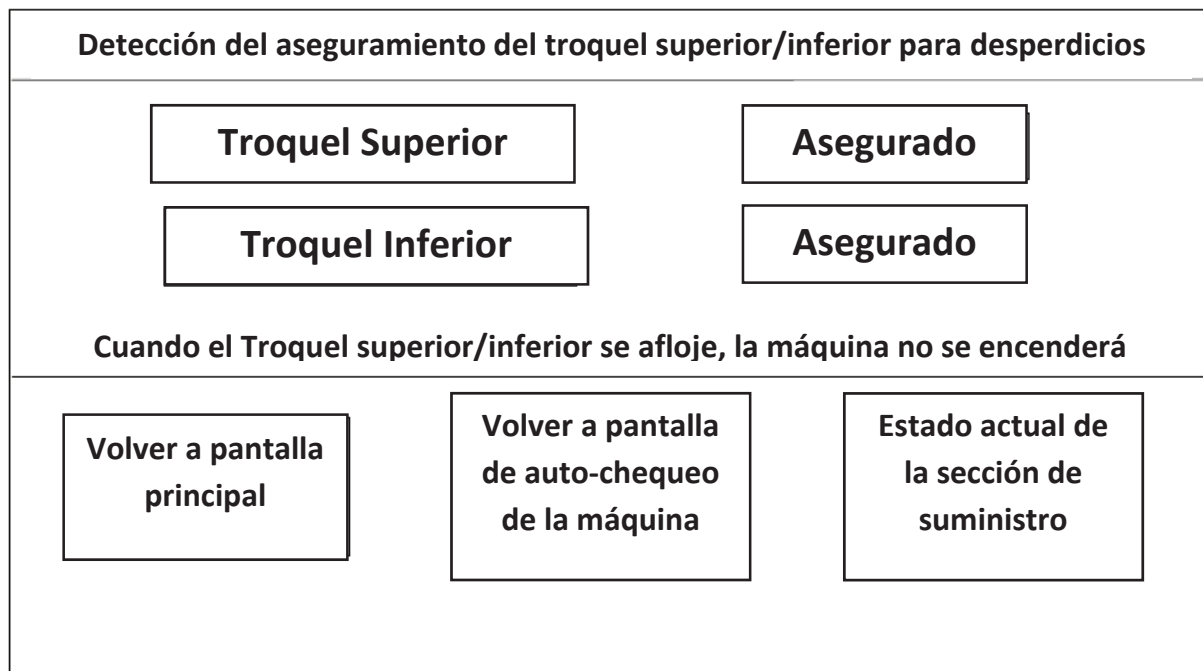

Pantalla # 213

Auto-chequeo de la sección de Suministro

Delivering Section Current Status		
Estado de la mesa de suministro	Detenido	
Posición de la mesa de suministro	En el límite	
Cilindro de suministro	Extender	
Transferencia de la pila del suministro	Auto	
Volver a la pantalla principal	Volver a la pantalla de auto-chequeo de la máquina	Volver a la página anterior

ETERNA

INSTRUCCIONES
PE1620SA-Extra

Capítulo 11

MANTENIMIENTO Y LUBRICACIÓN

11. MANTENIMIENTO Y LUBRICACIÓN

11.1. ÍTEMS DE MANTENIMIENTO Y LUBRICACIÓN

1. Barra de sujeción (incluyendo la cadena y racores de entrada de aceite) debería ser lubricada una vez al mes.
 2. Reciclado del Sistema automático de lubricación en la Sección de Troquelado.
 - A. Bomba: Una vez cada semana, levante el filtro para descargar el desperdicio.
 - B. Lubricación: Medidor de presión de aceite debería ser observado de vez en cuando, este debería ser mantenido con un nivel apropiado de aceite. Si el nivel de aceite es muy bajo para que circule, el sistema de alternado puede sobrecalentarse debido a la fricción. En este punto, el medidor de presión mostrará que el nivel de aceite está por debajo de nivel de alerta y la máquina va a detenerse automáticamente.
 3. Bomba Manual de Aceite para Lubricación: Para bombear el aceite de la bomba una vez por semana, oprimiendo la palanca al menos tres veces.
 4. Racor de Grasa: Para engrasar los racores una vez a la semana.
 5. Bomba de Vacío: Refiérase a las *Instrucciones del Compresor de Aire*.
- Nota: Para cambiar el aceite 3 meses después de la instalación de la máquina. Para denar todo el aceite en el reservorio y llenar nuevamente 25 galones de aceite (1001). Luego de eso, para cambiar el aceite cada 3 meses. Si la máquina realiza corridas en promedio 16 horas cada día laborable, el aceite debe de ser reemplazado cada 3 meses.
6. Cuadro de Aceite:

Código Internacional	Partes	Volumen (Litros)
MOBIL DTE25	Sistema de Reciclado y Lubricación	100
Mobile Gear SHC 460	Guarnición de Leva de Aceite e Indexación	72
Mobilux EP2	Soporte Lineal	1
Mobilux EP023	Todas los racores de engrasado	1
ISOVG32	Tubería de Aire	1

11.2 SISTEMA AUTOMÁTICO DE LUBRICACIÓN Y RECICLADO

1. Lubricación para el Mecanismo accionado por el cigüeñal

El mecanismo alternador del cigüeñal en la sección de troquelado es una parte muy importante en la máquina. Todos los puntos de Lubricación mostrados en la Fig.11.1 deben ser aceitados. De ese modo, el sistema automático de lubricación y reciclado es usado en esta parte para garantizar la apropiada lubricación en cada uno de los puntos.

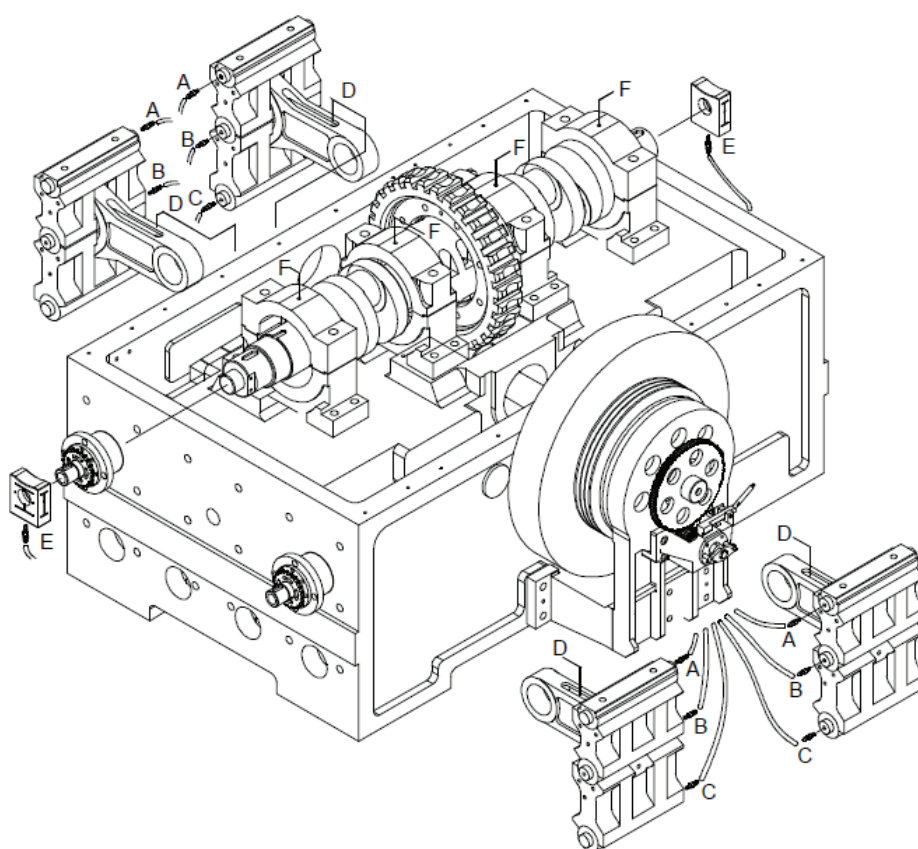

Fig.11.1

- A. Alternado de vara (Superior)
- B. Alternado de vara (Medio)
- C. Alternado de vara (Inferior)
- D. Brazo Conector
- E. Bloque metálico deslizable
- F. Árbol de Leva

2. Sistema de Bomba de Lubricación (Fig.11.2)

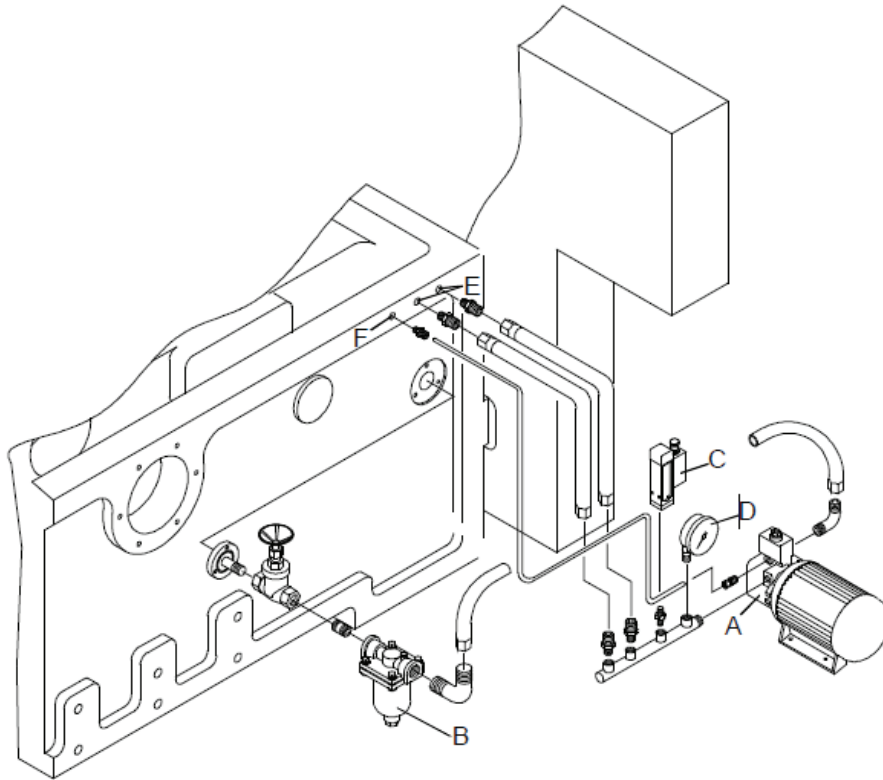

Fig.11.2

- A. Bomba de Aceite
- B. Filtro
- C. Válvula de Presión
- D. Medidor de Presión
- E. Mecanismo de árbol de levas (Entrada de Aceite)
- F. Salida de Aceite

3. Filtro de Aceite (Fig.11.3)

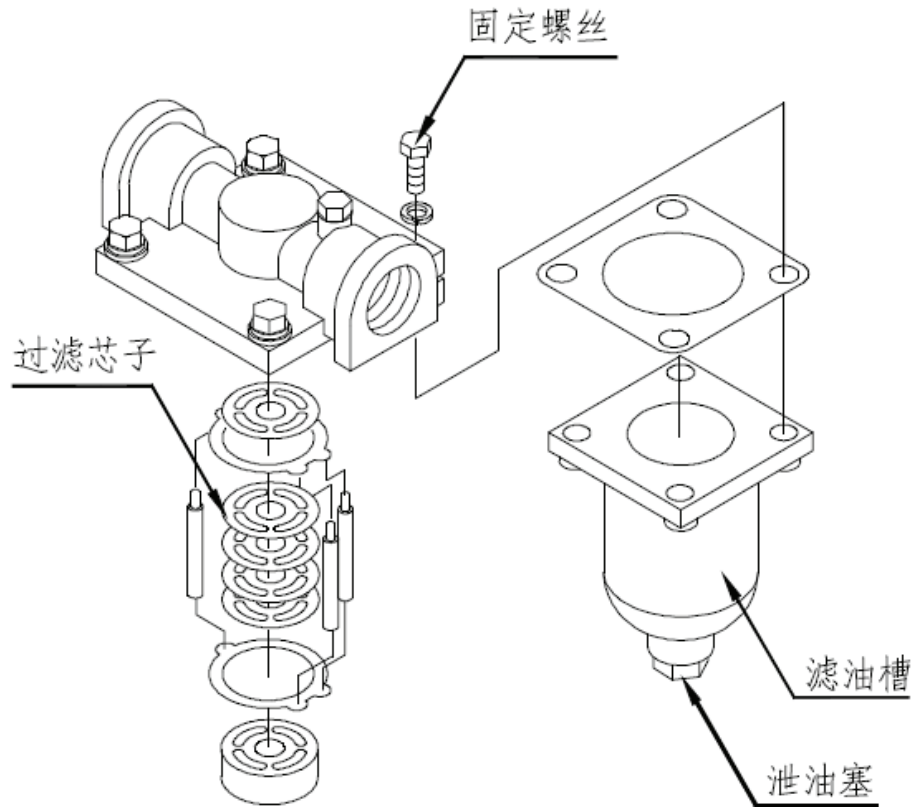

Fig.11.3

1. El Filtro de aceite en la entrada de la bomba debe de ser limpiado frecuentemente.
2. El núcleo del filtro debe ser despojado de desperdicios y limpiado cada mes.

Cómo limpiar el núcleo del filtro:

- Remover los 4 tornillos.
- Tire de la guarnición y luego sáquela.
- Retire el de la guarnición, voltee la guarnición, despoje el desperdicio, luego limpie la guarnición.
- El núcleo del filtro debería también ser limpiado completamente (Para soplar con aire comprimido de keroseno).
- Póngalo de vuelta en orden reverso para que encaje y pueda volver a su posición original.

4. Medidor de Presión de Aceite

Existe un medidor de presión de aceite en la base entre la sección de troquelado y la sección de desecho. El aceite debe ser mantenido en un nivel apropiado. Si el nivel de aceite es muy bajo para que circule, el sistema de alternado puede sobrecalentarse debido a la fricción. En este punto, el medidor de presión mostrará que el nivel de aceite está por debajo de nivel de alerta y la máquina va a detenerse automáticamente. (Presión normal: 1.5 – 2Kg/cm²)

11.3 BOMBA MANUAL PARA LUBRICACIÓN CENTRAL Y RACORES DE ENGRASADO

1. Bomba: La bomba debe ser operada cada semana, y para cada lubricación la bomba debe de ser presionada al menos 3 veces
2. Racores de engrasado y puntos a ser engrasados: El Engrasado debe de ser llevfasdo a cabo una vez por semana.
 - A. Racores de engrasado
 - B. Bloques auto lubricados



Figura 1. Boquilla de crema del mecanismo frontal de lubricación de la cinta transportadora. (Simétrico, llenado tipo A)



Figura 2. Repisa de apoyo móvil (simétrico), tipo de llenado de aceite: Tipo A



Figura 3. Mecanismo de Gusano del Alimentador. Tipo de llenado de aceite: Tipo A



Figura 4. Guía de Vara de tornillos laterales (simétrico). Tipo de llenado de aceite: Tipo A

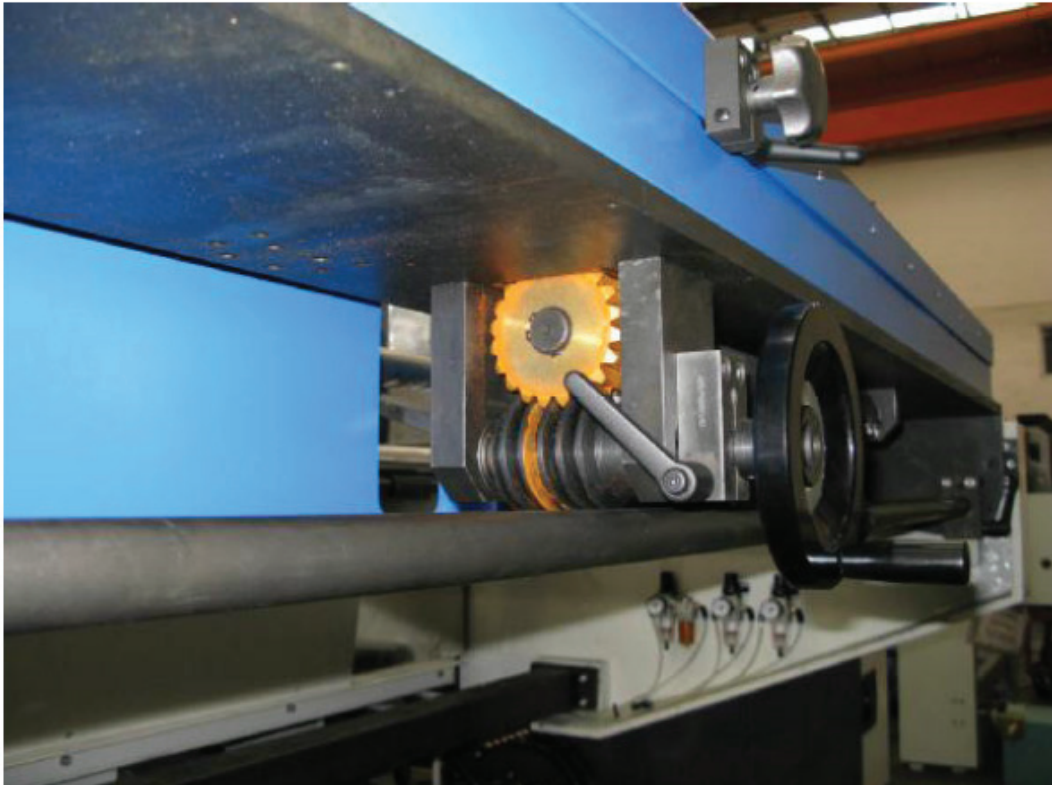

Figura 5. Apoyo Cadena del mecanismo de leva del alimentador .Tipo de llenado de aceite: Tipo B



Figura 6. Escape de casquillos metálico. Tipo de llenado de aceite: Tipo B

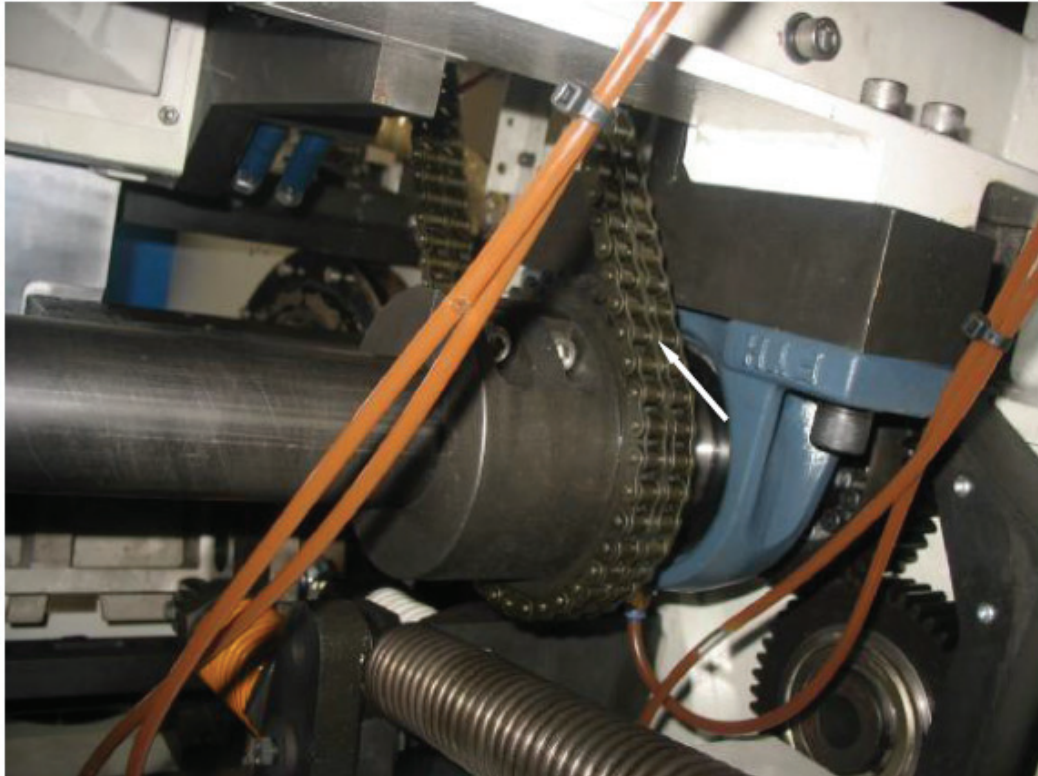

Figura 7. Llenado de leva del alimentador. Boquilla de crema de rodillos del alimentador (simétrico). Tipo de llenado: Tipo A

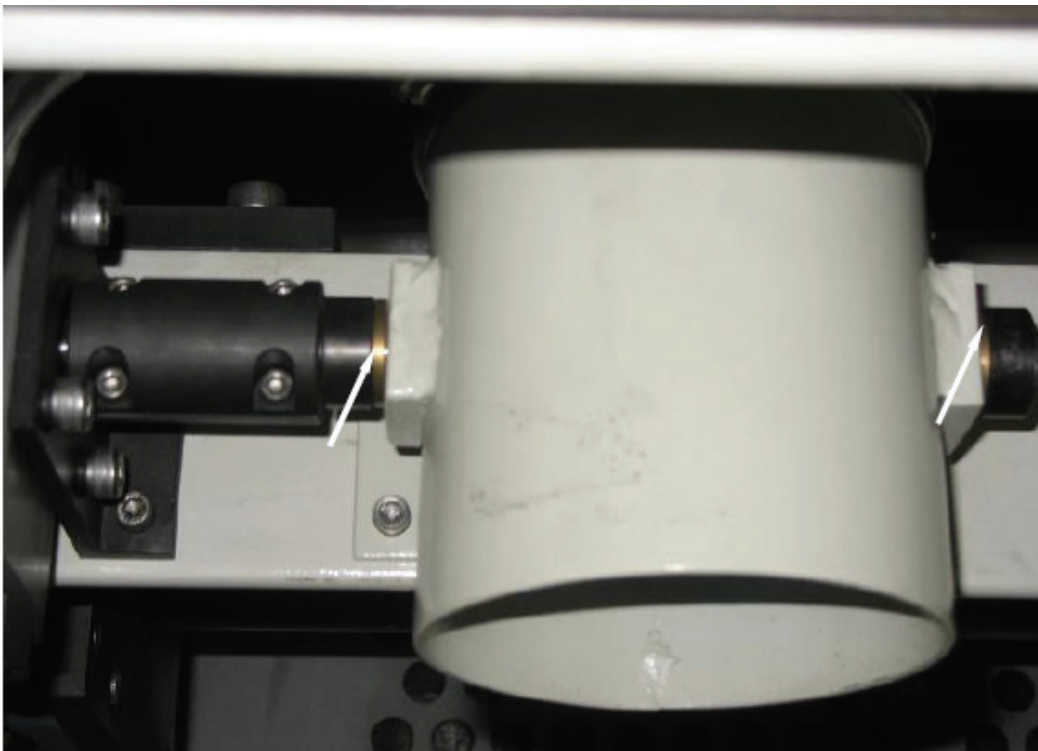

Figura 8. Llenado de leva del alimentador. Tipo de llenado de aceite: Tipo B

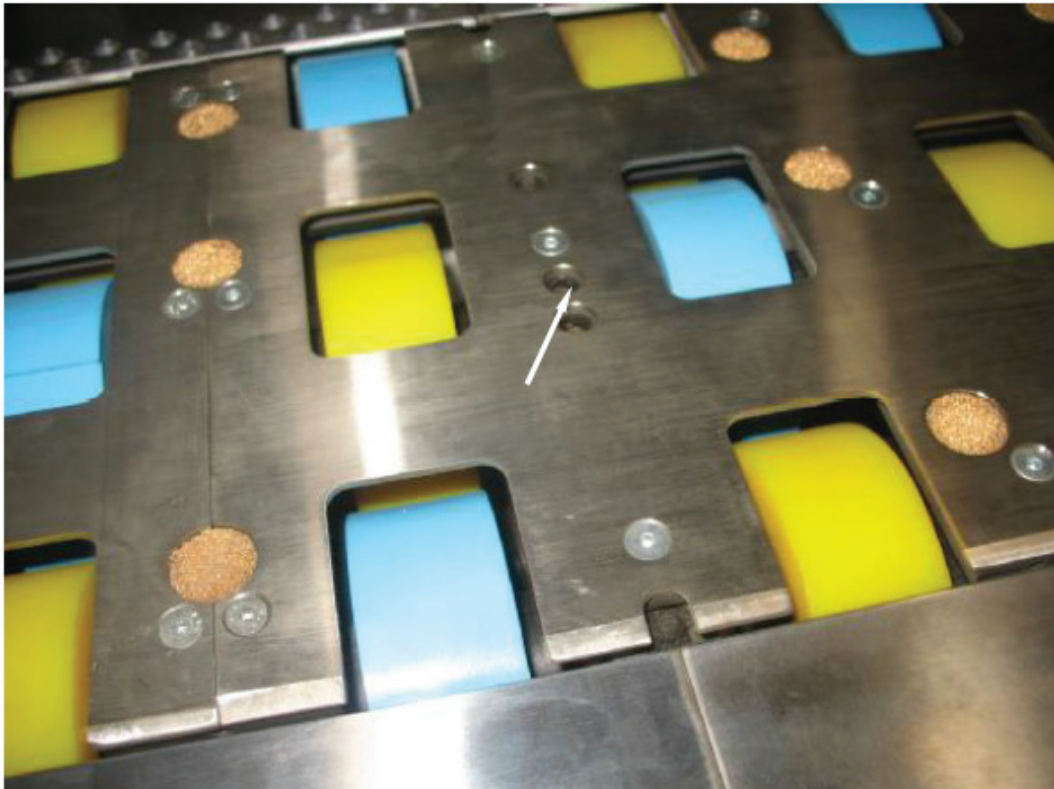

Figura 9. Unión de la barra de sujeción. (8 piezas. Simétrico) Tipo de llenado de aceite: Tipo B

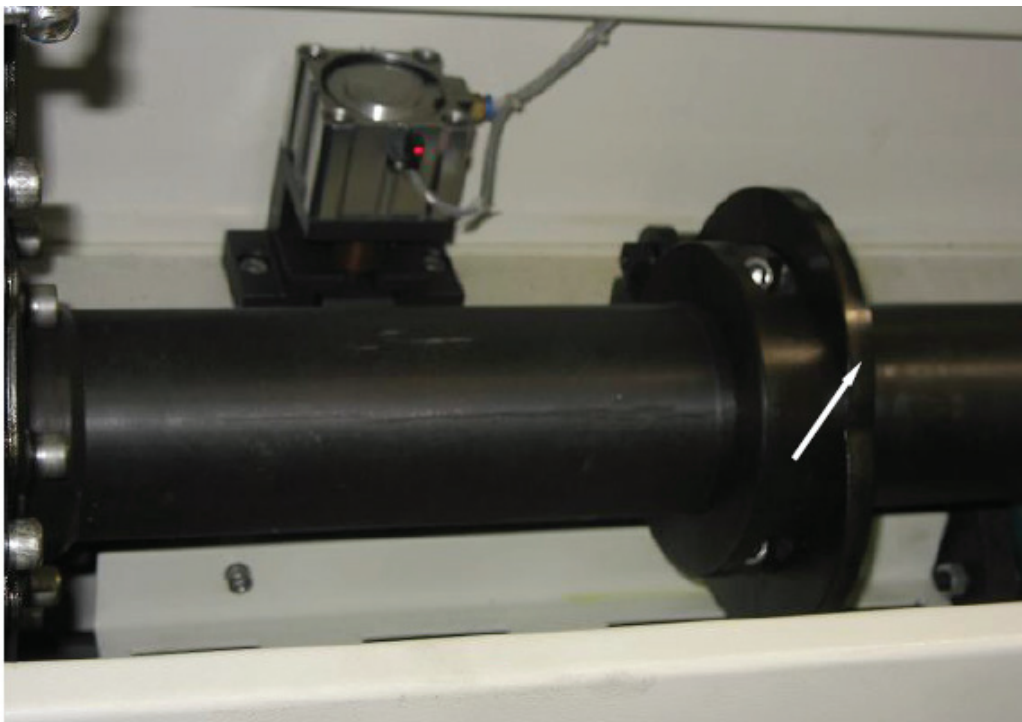

Figura 10. Bloque deslizable de posicionamiento trasero de la barra de sujeción. (Simétrico). Tipo de llenado de aceite: Tipo B

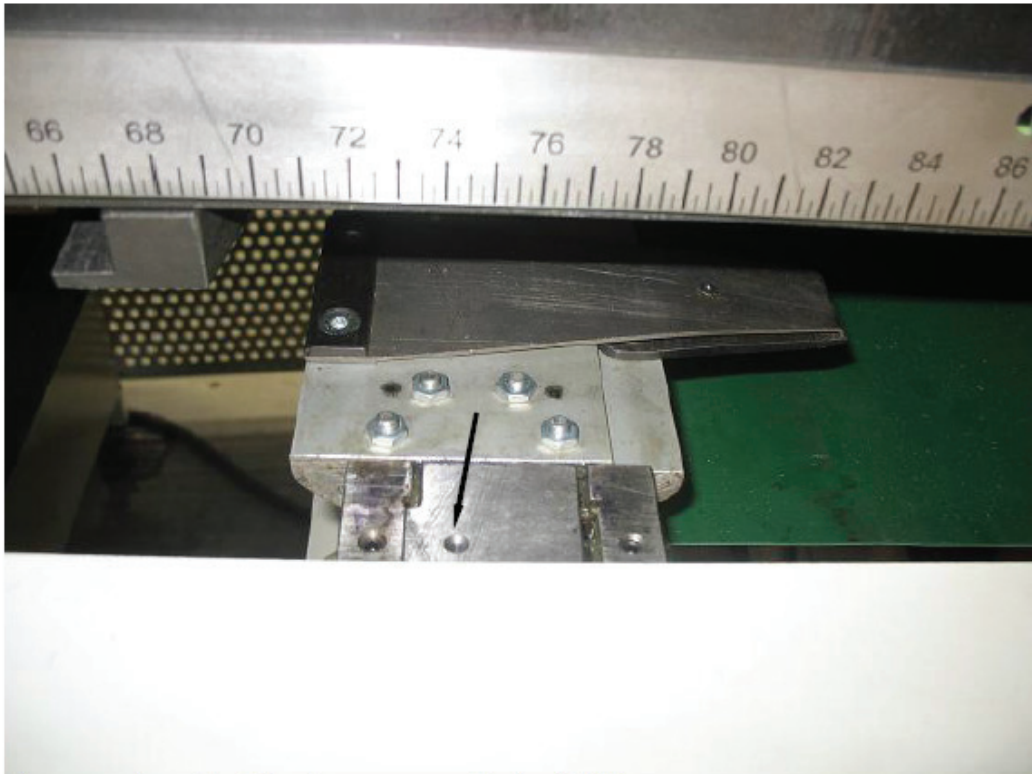

Figura 11. Vía trasera de guía de apoyo de papel. (Simétrico) Tipo de llenado de aceite: Tipo B

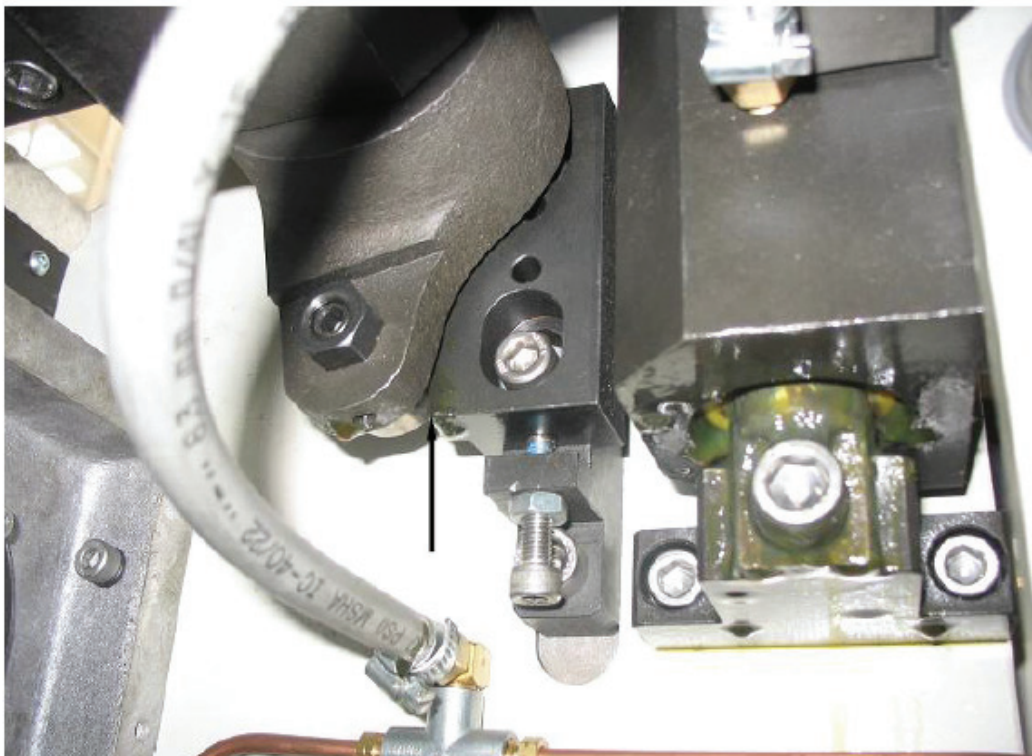

Figura 12. Barrera de sección de Suministro. (Simétrico). Tipo de llenado de aceite: Tipo B

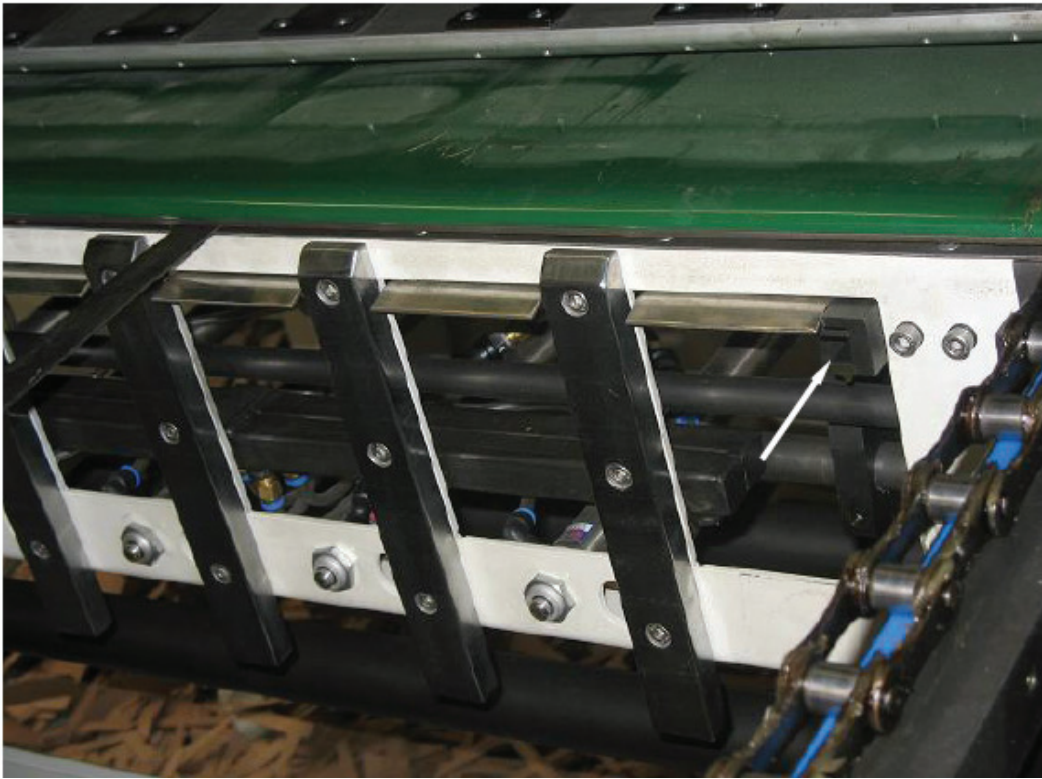

Figura 13. Parte superior de la Vía de Guía lineal del asiento para desperdicios. (Simétrico) Tipo de llenado de aceite: Tipo B

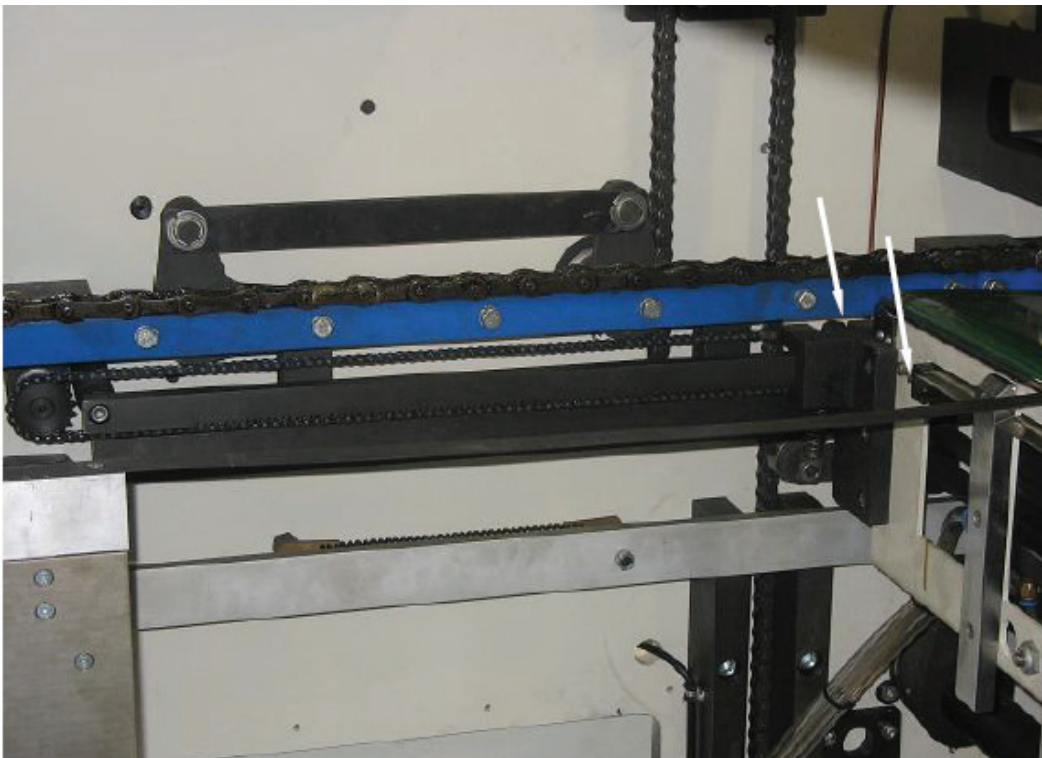

Figura 14. Parte inferior de la Vía de Guía lineal del asiento para desperdicios. (Simétrico) Tipo de llenado de aceite: Tipo B

3. INTERVIEW WITH JIMMY GARCIA (ENGLISH)

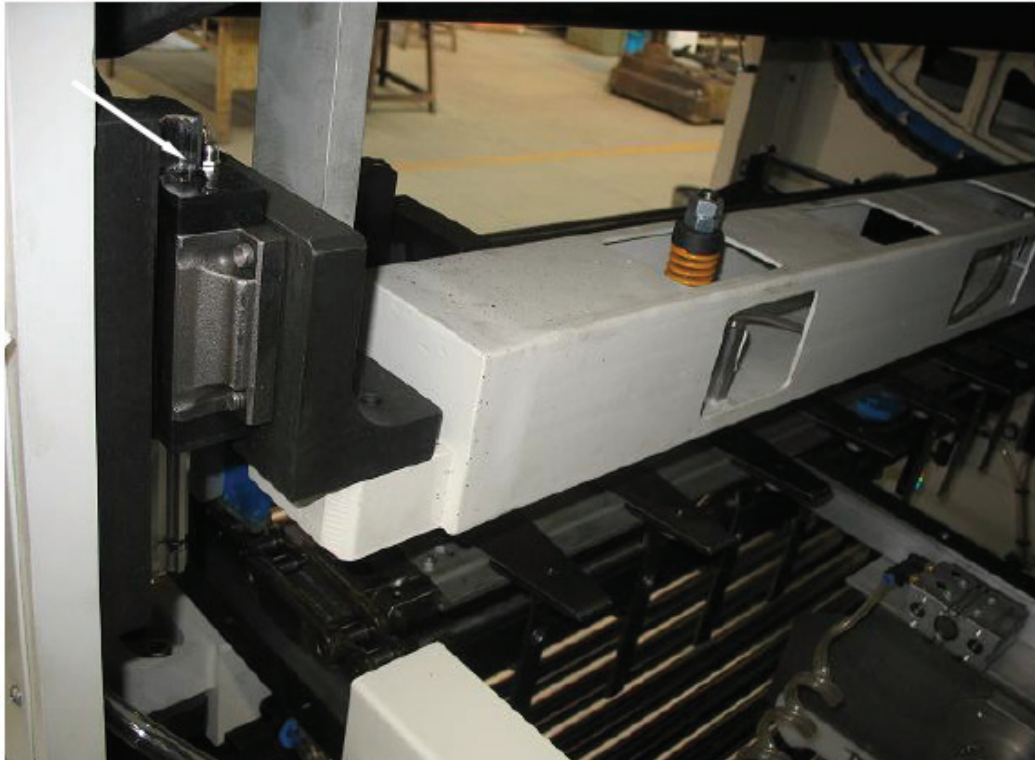
Transcript in English of Interview with questions asked to Mr. Jimmy Garcia, person in charge of managing documentation in die cutting department at PROCARSA.

Location: PROCARSA (DieCutting Industry)

Interviewer: Kennie Clark

Interviewee: Mr. Jimmy Garcia (PROCARSA Representative)

Date: 20 April, 2013

KC=Interviewer

JG=Interviewee

➤ KC

Good afternoon Mr. Garcia. Thank you for attending to my petition. I am planning on doing some research about the applicability of translation in the Diecutting business. I understand that PROCARSA has recently undergone several restructuring in Staff and in processes. My main concern is the following: How does PROCARSA cope with the International Standards that its webpage so neatly advertises?

➤ JG

Well, if you are referring to the way PROCARSA ensures compliance with International Standards in terms of readily available documentation I must say we have been taking measures to update our documentation because the company wants to earn another accreditation from an international quality assurance creditor. Our documentation is being checked and rechecked so that everything is verifiable and can be traced accordingly.

➤ KC

Oh I see.

And, can you tell me with respect to the manuals that the company owns and uses, have you had any problems or unforeseen happenstances with these assets?

Do you think the staff (machine operators) have a thorough knowledge of the processes found in manuals and thus know how to tackle any problem that may arise with the machines?

➤ JG

We only hire experienced workers and they are proficient at their duties. They have been able to manage all instances of malfunctioning that have occurred even if their occurrence is not considerable.

➤ KC

Mr.' Garcia, are the manuals that the company owns in all languages as prescribed by organisms such as the CE and ISO directives?

➤ JG

Our operators speak Spanish and some know technical English. Our manuals are in English chiefly because machines that the company purchases come from Asia and Europe, very rarely they come with a manual in Spanish strictly from the manufacturer. May I ask what you are implying with your question?

➤ KC

Certainly. My aim is to justify the translation of the documentation needed to ensure compliance with the international bodies that issue quality assurance certifications. According to what you just told me the staff that operates machines do not have a communicative level of English but they manage technical proficiency at it.

It seems as if the manufacturer that issue the manuals only sends them in English and that the staff, based on their expertise, find little problems operating machinery. However, May I ask you what would happen if a machine were to malfunction and the staff, no matter how expert they may be, cannot solve the problem because it had never happened to them? What source would they recur to in order to solve it? Would they be endangering their safety by trying to solve the problem "blindfolded", without a reliable document pertaining factual information about the operation of the machine?

➤ JG

Wow! Those are lots of questions, well I suppose in that case the only way to solve it could be generated from using the manuals but as you previously pointed out, these only come in English language and the knowledge of the staff is limited to certain vocabulary. On these grounds I would consider that there is a need for having documentation not only up to date but also in the mother tongue of the staff, in this case Spanish. What would you suggest?

➤ KC

I would give the staff the necessary tools to do their job. Among those tools are the means necessary for the safe operation of the machines. I am supremely confident that the company ensures safety procedures for all personnel but having manuals to which they can go to in the case of a malfunction is vital to complying with many of the international bodies previously discussed. Would you say that at least the most immediate need regarding the manuals of the machines that the staff most frequently operate would be the priority?

➤ JG

There is one machine that is being used very frequently by the staff, it's a new machine brought from China, a diecutter machine. I would say that if any manual had to be translated the one from that machine would be priority. I see your point. In addition to this the staff may manage to understand only basic vocabulary from the English language and at any moment their proficiency could be tested and succeed but there are procedures that need be followed if we want to comply with ISO and the new projects coming in the

following years. To talk in numbers I can ponder that about 10% of the staff that would be 30 operators know English at a functional level, i.e. to a level in which they can communicate effectively but in a limited environment. 90% of the staff only used English (technical English) in order to operate machinery with very basic instructions such as ON and OFF or dispatch or load procedures. Can you help us with this?

➤ KC

Sure I need to know the procedures that are in the manual and the nature of it so that I can tell you how feasible is to render a translation and in what time. Would you feel comfortable if we discussed this via email? I see you are somewhat worried about the time. I am sorry I have taken up so much time on this.

➤ JG

As a matter of fact I have a meeting to attend to. If you'll excuse me. Please send me an email to remind me of this conversation so that we can move on with the project you are suggesting. My secretary will give you my email address and we will be in touch. Thank you for your visit. Do not forget to send me that email.

➤ KC

Okay. I will talk to your secretary to get the information I need to contact you. Have a great day.

➤ JG

You too. Thanks again.. I have to rush

4. PHOTOS OF ETERNA MACHINE.



Picture 1 ETERNA Diecutter flatbed machine

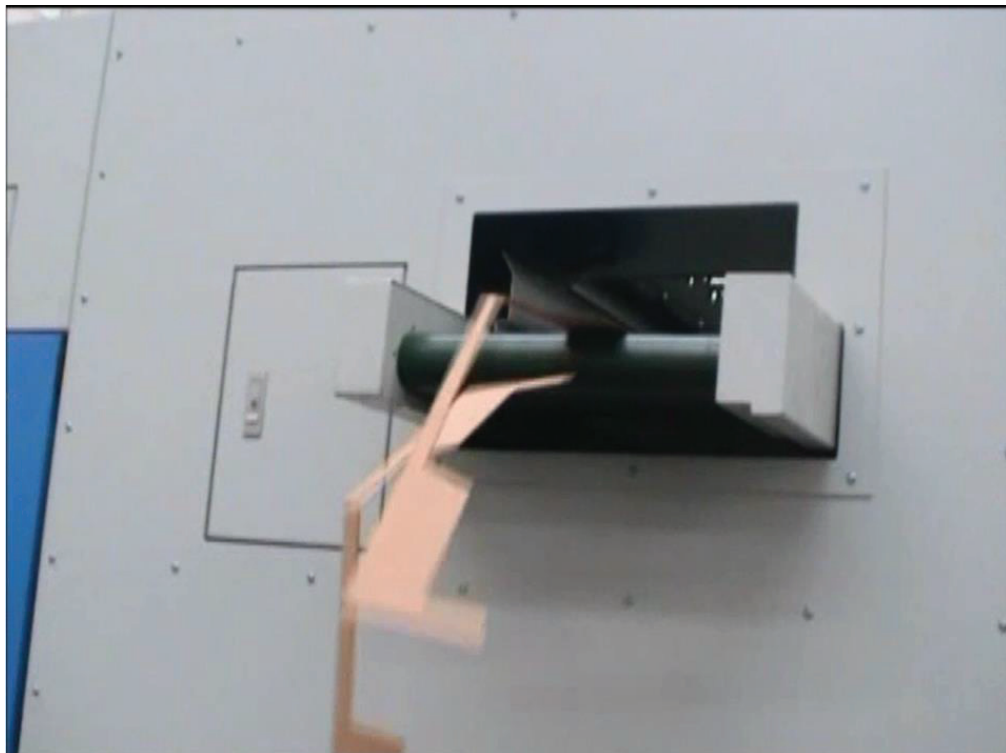

Picture 2 Section for trimming cardboard waste material



Picture 3: Machine at PROCARSA – Waste disposal section

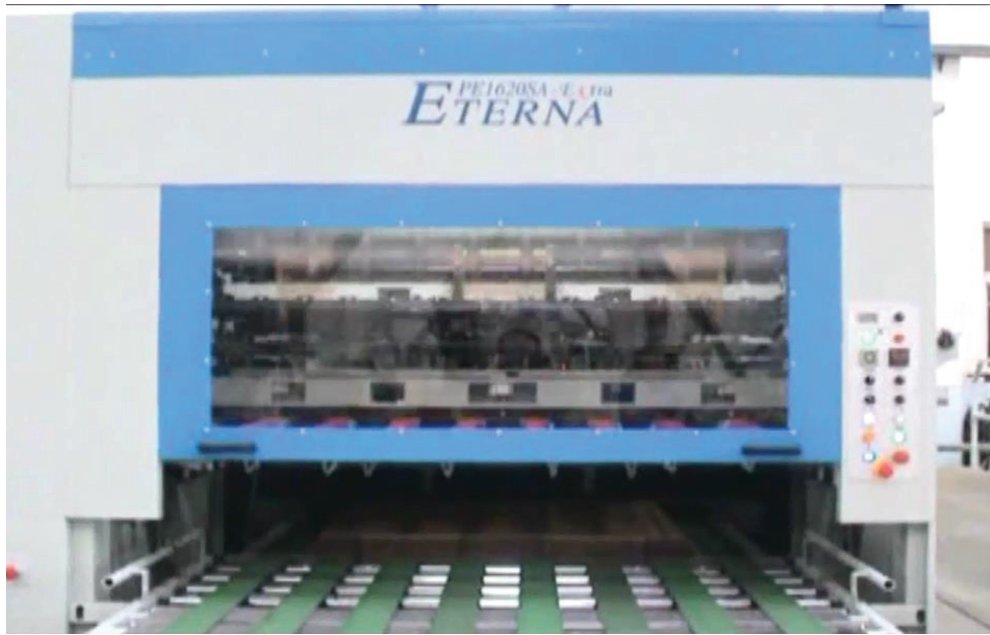

Picture 4: Batch Counter Belt



Picture 5: Machine Operator carrying a wooden ward blueprint for the die cutter



Picture 6: Machine at PROCARSA -Delivery and In feeder

DOCUMENTATION ABOUT ETERNA MACHINE - SPECIFICATIONS



**PE1620SA-E Xtra
FLOOR PLAN**



**PE1620SA-E Xtra
FLOOR PLAN**

Specifications	
Max. Sheet Size	1620 x 1200 mm
Min. Sheet Size	650 x 450 mm
Max. Cutting Size	1600 x 1180 mm
Inner Chassis Size	1630 x 1210 mm
Stock Range	E, B, C, A and AB flute corrugated board
Min. Gipper Waste	12 mm
Max. Mechanical Speed	4500 cycles/hour
Max. Cutting Pressure	400 tons
Total Power Required	35 kW
Main Motor Power	22 kW
Total Net Weight (approx.)	32 tons
Machine Dimensions	9980(L)X5670(W)X2480(H)mm (incl. Canwalk)

In the interest of product improvement, the manufacturer reserves the right to change specifications and features without notice.



ETERNA Shanghai Eterna Machinery Co., Ltd.

Shanghai Plant:
No. 123 Tianhe Road, Pudong, Shanghai
Tel: 86-21-58026451 (9:00am-5:45pm)
Fax: 86-21-58026477
E-mail: eterna.shanghai@gmail.com

Shanghai Office:
No.2870, Luchuan Road, Shanghai 200333, China
Tel: 86-21-44262338
Fax: 86-21-44262133
E-mail: eterna.shanghai@gmail.com

Agent 代理:

North American Office:
1-1500 Vantage Way, Richmond, BC, Canada
Tel: +1(604)2782227
Fax: +1(604)2781005



BRAUSSE GROUP
PE1620SA-E Xtra

ETERNA AUTOMATIC FLATBED DEECUTTING AND CREASING MACHINE WITH STRIPPING STATION AND LEAD EDGE FEEDER

SHANGHAI ETERNA MACHINERY CO., LTD.

Comment to access additional features.

AUTOMATIC FLATBED DIECUTTING AND CREASING MACHINE WITH STRIPPING STATION AND LEAD EDGE FEEDER PE1620SA-Extra



- DELIVERY SECTION**
- 2 Front, back and side joggers to ensure neat stacking
 - 2 Non-stop delivery assures continuous productivity
 - 2 Batch counter output



- BATCH COUNTER BELT TYPE DEVICE**
- 2 Escalator delivery fork with non-stop air cylinder and conveyor belt delivery table to prevent the sheets from scratching and for neat sheet stack delivery



- STRIPPING SECTION**
- 2 Heavy duty double action stripping system to ensure positive stripping
 - 2 Compatible to Contefline II for quick changing set up
 - 2 Motorised upper frame suspending holder
 - 2 Quick lock stripping pins used for quick set up of simple stripping work



- ETERNA LEAD EDGE FEEDER**
- 2 Allows consistent and precise feeding of wide range computer board with various board quality
 - 2 Unique polyurethane wheel surface with grid filter and air cushion ensures smooth feeding of warp boards with consistency and register accuracy
 - 2 Front gauge position back and forth adjustable to accommodate variation in gippen margin according to the job specification
 - 2 Press vacuum support system through infrared adapts to wide range of stock thickness from 1mm to 20mm



- DIECUTTING SECTION**
- 2 Safety door and discharge safety locking system to ensure safe operation
 - 2 Complete lost sheet control throughout the entire machine
 - 2 Contefline system compatible to Contefline II for quick change over and short set up time
 - 2 Air cushion underneath the cutting plate for easy cutting plate handling in and out